

West Penetone Inc. Installation & Operation Instructions

Model # WEST 976560 · Timed Entryway HV Foam Sanitizer

REQUIREMENTS

Chemical Concentrate

Water

Temperature	up to 160°F
Pressure	35-125 PSI
Flow	4 GPM @ 40 PSI
Supply Line	3/4" Min

Compressed Air

up to 5 CFM

Hose/Pipe

1" & 3/4" ID

Nozzle

HV Entryway Spreader (2 - use both)

Electric

120V

OPTIONS

Stainless Steel Jug Racks

2 ½ Gallon (8 ½" x 10 ½")	# 224210
5 Gallon Round/Square Locking (12" x 12")	# 224214
5 Gallon Round/Square (12" x 12")	# 224215

Control Box Upgrades (Specify at Time of Purchase)

Photocell Activation Upgrade	# 976001EE
Push Button Activation Upgrade	# 976001PB

Dual Pick-up Assembly

HV Entryway Dual Chemical Pick-up Assembly	# 976013
--	----------

Alternate Chemical Check Valve - Viton Standard

Check Valve, Chemical, PP(W), 1/4" (EPDM)	# 491401
---	----------

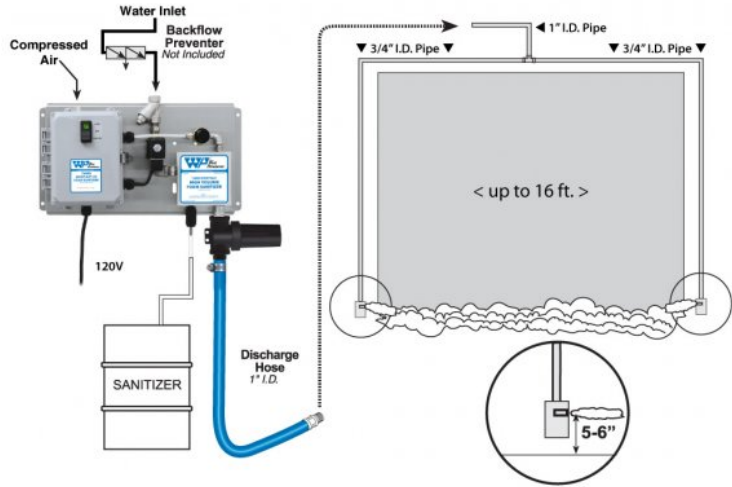

<http://www.westpenetone.com/>

Montreal: 1-800-361-8927

Edmonton: 1-866-454-3919

**WARNING! READ ALL
INSTRUCTIONS BEFORE
USING EQUIPMENT!**

OVERVIEW

The Timed Entryway HV Foam Sanitizer is an automated foam applicator for projecting sanitizing chemicals on to floors of 8' - 16' wide overhead doors to prevent cross contamination. When activated, this venturi injection system uses city water pressure (35 - 125 PSI) to draw and blend chemical concentrate into the water stream to create an accurately diluted solution. A high volume of rich, clinging foam is created by injecting compressed air into the solution to greatly increase volume and coverage ability. The foam is then projected through the discharge hose and unique Spreader™ nozzles. The system timer is user-programmable to meet the needs of any facility.

SAFETY & OPERATIONAL PRECAUTIONS

- When connecting to a potable water supply follow all local codes for backflow prevention.
- See Additional Safety Precautions included with the Electrical Control Box Installation Information
- Always consider electrical shock hazard when working with and handling electrical equipment. If uncertain, consult an Electrician. Electrical wiring should only be done by a qualified Electrician.
- For proper performance do NOT modify, substitute nozzle, hose diameter or electrical control box.
- Manufacturer assumes no liability for the use or misuse of this unit.
- Wear protective clothing, gloves and eye wear when working with chemicals.
- Always direct the discharge away from people and electrical devices.
- Follow the chemical manufacturer's safe handling instructions.
- NEVER mix chemicals without first consulting chemical manufacturer.
- Disconnect electrical power to the control box prior to opening it.
- If the control box is connected to compressed air, the compressed air pressure should be kept to a maximum of 90 PSI.

TO INSTALL (REFER TO DIAGRAM ON NEXT PAGE)

Illustration on Page 1 shows overall system setup. Refer to companion instructions for control box upgrades.

1. Install foam enhancer to entryway foamer discharge. The arrow on the foam enhancer should point UP - opposite the flow direction.
2. Mount the unit to a suitable surface above chemical supply to prevent siphoning.
3. Frame the doorway with 3/4" ID piping (not included), as shown in the illustration on Page 1.
4. Mount the spreader nozzle slots 5-6" off the floor, a little higher for wider entryways. Use **both** nozzles.
5. Connect the unit to the 3/4" pipe frame using the provided 10' hose (1" ID) and 1" ID piping. Each nozzle should be the same distance from the connection between 1" and 3/4" piping to ensure simultaneous activation. Use as few elbows as possible. *Hose/pipe ID is very important.*
6. Connect water and compressed air to the unit.

Set the chemical dilution ratio by threading one of the color coded metering tips into each chemical check valve. See chemical labels for dilution ratio recommendation or consult your chemical supplier.

- For the strongest dilution ratio do NOT install a colored metering tip.
- The dilution ratios in the metering tip chart are based on water thin chemicals with a viscosity of 1CPS.
- Thicker chemicals will require a larger tip than the ratios shown in the chart.
- Application results will ultimately determine final tip color.
- Select the tip color that is closest to your desired chemical strength and thread it into the tip holder. **DO NOT OVER-TIGHTEN.**
- Push the chemical tube over the check valve barb and place the suction tube in the chemical concentrate.
- If necessary, cut suction tube(s) to length before attaching suction strainer.

TO OPERATE

TO TEST

1. Plug the power cord into 120 VAC outlet.
2. The unit has been tested and the timer is preset to run for 60 seconds to allow for final adjustments. (ON TIME will activate first.) Open water supply valve and air supply valve, then turn on the power switch.
3. The unit will activate and final chemical dilution and air adjustments will now have to be made.
4. Wait a few seconds and observe foam consistency.
 - Use the least amount of air needed to achieve good foam quality to prevent water pressure fluctuations from affecting performance. Air pressure must be kept lower than water pressure.
 - To adjust foam consistency pull out on the air regulator knob, turn slightly clockwise for dryer foam and counterclockwise for wetter foam. Wait a few seconds to see each adjustment.
 - You may have to try different metering tips and air settings until foam output is acceptable. Once this is set and desired foam consistency is achieved push lock the knob. You are ready to start.

TIMER ADJUSTMENT

1. CAUTION! UNPLUG THE POWER CORD! Then open control box and adjust the timer. The ON TIME dip switches control how long the foam will be applied. The OFF TIME dip switches control how long the unit will stay off between foam applications. Add up the seconds for each activated dip switch to arrive at the desired duration of the ON cycle. Usually 8-10 seconds is sufficient to foam the floor (longer plumbing runs will require a longer application cycle). Add up the minutes for each activated dip switch to arrive at the desired duration of the OFF cycle. Set your OFF TIME to maintain the foam's presence according to your flow (anywhere from 6 to 15 minutes).
2. Close control box and plug in the power cord. Turn on the power switch. The unit will now function according to the timer settings. (ON TIME will activate first.)
 - Note: The unit will run 24 hours a day unless the power switch is manually turned off.
 - For extra foam at any time, press and hold the lower end (Momentary control) of the door switch. (See Switch Settings, below.)

SWITCH SETTINGS (on front of Control Box)

- Automatic control – Top of switch is depressed. Green light glows.
- OFF – Switch is in middle position; green light is off
- Momentary control – Press bottom of switch. Unit is active only while switch is pressed. When released the

METERING TIP SELECTION

METERING TIP COLOR	OZ/MIN	DILUTION RATIO @ 40 PSI
Brown	0.56	914:1
Clear	0.88	582:1
Bright Purple	1.38	371:1
White	2.15	238:1
Pink	2.93	175:1
Corn Yellow	3.84	133:1
Dark Green	4.88	105:1
Orange	5.77	89:1
Gray	6.01	85:1
Light Green	7.01	73:1
Med. Green	8.06	64:1
Clear Pink	9.43	54:1
Yellow Green	11.50	45:1
Burgundy	11.93	43:1
Pale Pink	13.87	37:1
Light Blue	15.14	34:1
Dark Purple	17.88	29:1
Navy Blue	25.36	20:1
Clear Aqua	28.60	18:1
Black	50.00	10:1
No Tip Ratio Up To:		6:1

The dilution ratios above are approximate values. Due to chemical viscosity, actual dilution ratios may vary.

FORMULA

GPM × 128 ÷ Desired Dilution Ratio = oz/min

- See Unit Flow Rates chart for GPM
- Use 20 for 20:1 dilution ratio, 30 for 30:1, etc.
- Match calculated ounces per minute (oz/min) to nearest oz/min in Metering Tip Selection chart.

UNIT FLOW RATES

PSI	GPM
35	3.74
40	4.00
50	4.47
60	4.90
70	5.29
80	5.66
90	6.00
100	6.32
110	6.63
120	6.93
125	7.07

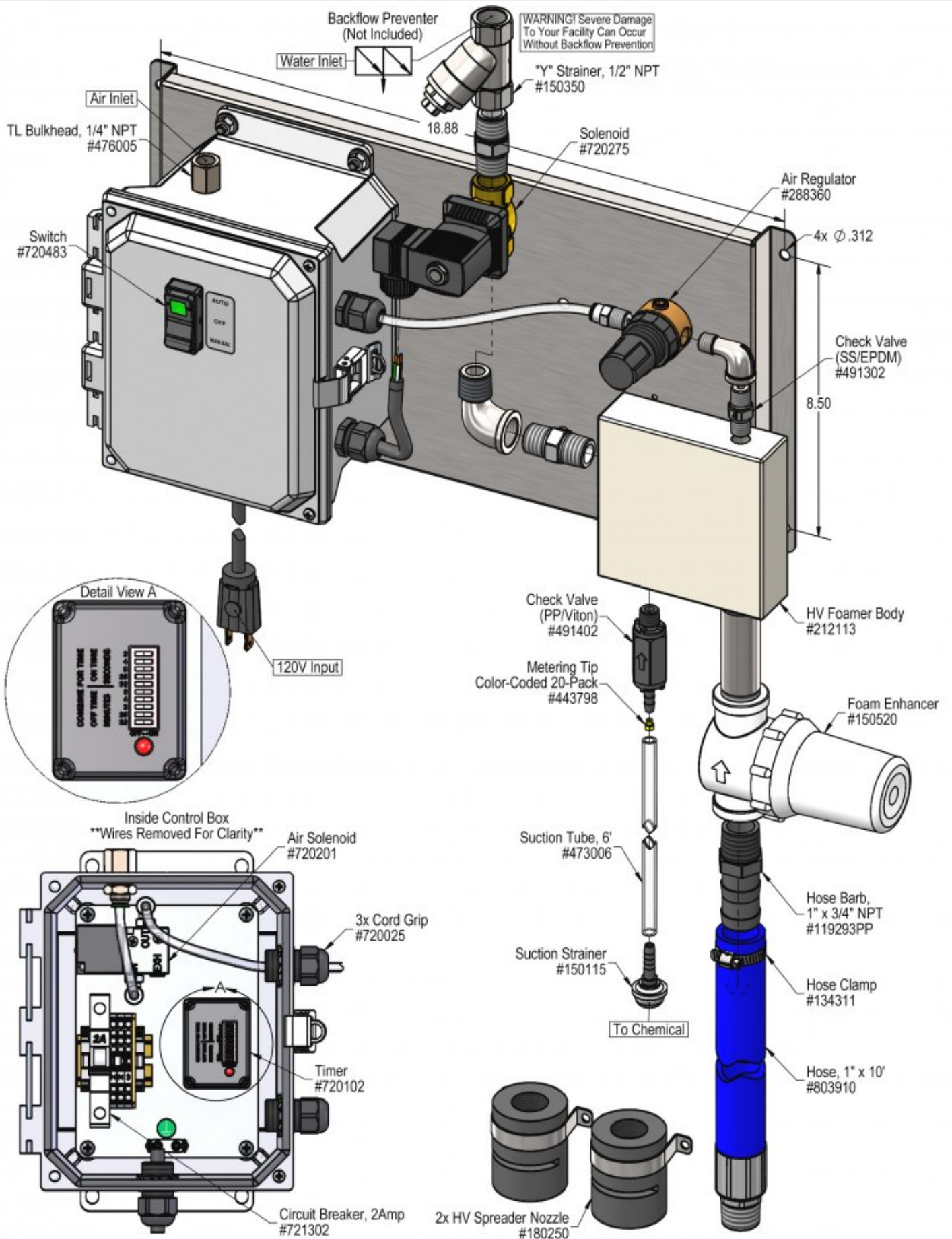

Troubleshooting Guide

Problem	Possible Cause / Solution	
	Startup	Maintenance
A) Foamer will not draw chemical.	1, 7, 8, 9, 10	13, 14, 15, 16, 17, 19, 20
B) Foam surges.	1, 2, 3, 4, 6, 7, 8, 9, 10	13, 14, 15, 16, 17, 19, 20
C) Foam output too wet.	2, 3, 4, 6, 7, 8, 9, 10	13, 14, 15, 16, 17, 18, 19, 20
D) Foam output too dry.	1, 5	17
E) Doesn't come on when switch is turned on.	11,12	
F) Comes on and runs continuously.	11	
G) Comes on but no water through solenoid.	10	19
H) Air or solution backing up into water line.		21

Possible Cause / Solution	
Startup	Maintenance
<ol style="list-style-type: none"> 1. Air pressure too high <ul style="list-style-type: none"> ◦ Adjust air regulator slowly counterclockwise until output stabilizes. 2. Air adjustment too low <ul style="list-style-type: none"> ◦ Adjust air regulator very slowly clockwise. 3. Use of an oiler in the airline will cause poor foam quality <ul style="list-style-type: none"> ◦ Use only clean, dry air. 4. Not enough chemical - metering tip too small <ul style="list-style-type: none"> ◦ Install larger metering tip. 5. No metering tip installed or metering tip too large <ul style="list-style-type: none"> ◦ Install smaller metering tip. 6. Improper chemical <ul style="list-style-type: none"> ◦ Ensure product is recommended for foaming and/or the application. 7. Chemical tube not immersed in chemical or chemical depleted <ul style="list-style-type: none"> ◦ Immerse tube or replenish 8. Foam hose kinked or hose/plumbing too short or wrong size <ul style="list-style-type: none"> ◦ (See REQUIREMENTS on page 1) ◦ Use <u>BOTH</u> spreader nozzles 9. Water pressure too low or water volume too low/inlet piping too small <ul style="list-style-type: none"> ◦ Increase water pressure or water volume. (See REQUIREMENTS on page 1) 10. No water to the unit <ul style="list-style-type: none"> ◦ Ensure that the water supply is not shut off to the unit. 11. Timer failed/Controller not set properly or malfunctioned <ul style="list-style-type: none"> ◦ Replace timer. See Controller manual. 12. May have electrical problems <ul style="list-style-type: none"> ◦ Ensure circuit breaker (5 Amp) has not been tripped. ◦ Have a qualified electrician check electrical connections. 	<ol style="list-style-type: none"> 13. Chemical check valve stuck or failed <ul style="list-style-type: none"> ◦ Clean or replace. 14. Chemical strainer or metering tip partially blocked <ul style="list-style-type: none"> ◦ Clean or replace chemical strainer and/or metering tip. 15. Chemical tube stretched out where tube slides over check valve or pin hole/cut in chemical tube (sucking air in) <ul style="list-style-type: none"> ◦ Cut off end of tube or replace tube. 16. Vacuum leak in chemical pick-up connections <ul style="list-style-type: none"> ◦ Tighten the connections. 17. Air regulator failed allowing too much air or not enough air <ul style="list-style-type: none"> ◦ Clean or replace. 18. Air check valve or air solenoid clogged or failed <ul style="list-style-type: none"> ◦ Clean or replace. 19. Water solenoid clogged or failed <ul style="list-style-type: none"> ◦ Clean or replace the water solenoid. 20. Chemical build-up may have formed in the body, causing poor or no chemical pick-up <ul style="list-style-type: none"> ◦ Follow PREVENTIVE MAINTENANCE instructions below, using hot water or descaling acid. When there is no draw at all, carefully remove fittings and soak entire body in descaling acid. 21. No backflow preventer installed <ul style="list-style-type: none"> ◦ Install appropriate backflow preventer into water line.

PREVENTIVE MAINTENANCE: When the unit will be out of service for extended periods, place chemical tube(s) in water and flush the chemical out of the unit to help prevent chemical from drying out and causing build-up. Periodically check and clean chemical strainer and replace if missing.

