



# Technical Manual

## *BENOMIC S 350*



**Berg Hortimotive**

**Burg. Crezeelaan 42a  
2678 KZ De Lier  
The Netherlands**

**Tel: +31 (0) 174- 517 700**

**Email: [info@berghortimotive.com](mailto:info@berghortimotive.com)  
Internet: [www.berghortimotive.com](http://www.berghortimotive.com)**

## Machine type plate

The *BENOMIC S* carries a machine type plate which contains the following data: Berg Hortimotive address details, CE marking, serial number and the year of manufacture.

If you would like to contact the Berg Hortimotive dealer with respect to the *BENOMIC S*, please ensure that this information is always readily available.

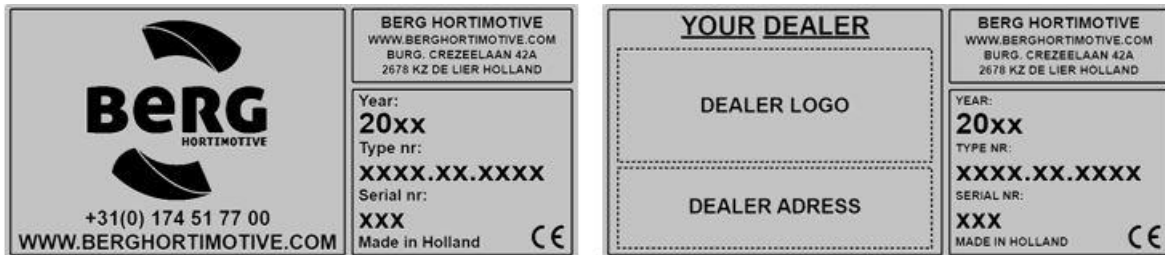

The machine is manufactured by:



Berg Hortimotive

Burg. Crezeelaan 42a  
2678 KZ De Lier  
The Netherlands

Tel: +31 (0) 174- 517 700

Email: [info@berghortimotive.com](mailto:info@berghortimotive.com)  
Internet: [www.berghortimotive.com](http://www.berghortimotive.com)



# 1. Declarations

## 1.1 Copyright

Berg Hortimotive  
De Lier, 2021

No part of this documentation may be reproduced and/or made public by means of print, photocopy, film or any other means without prior written permission from Berg Hortimotive in De Lier, the Netherlands – Except parts intended to be reproduced for the purpose of using this documentation such as abbreviated instructions and indications on the machine.

## 1.2 Liability

Berg Hortimotive is not liable for unsafe situations, accidents and damages resulting from the failure to observe warnings or regulations, as shown on *the BENOMIC S* and/or in this documentation, for example:

- inexpert or improper use or maintenance;
- use for applications or under conditions other than those specified in this documentation;
- use of parts other than those specified;
- repairs without permission from Berg Hortimotive and/or a certified dealer;
- modifications to *the BENOMIC S*. This includes:
  - changes to the controls;
  - welding, mechanical operations, etc.;
  - extensions or additions to *the BENOMIC S* or the controls.

Berg Hortimotive is also not liable in the following cases:

- if the customer has not fulfilled all his obligations toward Berg Hortimotive (financial or otherwise);
- for consequential damage caused by faults or defects on the *BENOMIC S* (e.g. business interruption, delays, etc.).

### 1.3 **Guarantee**

Berg Hortimotive guarantee is valid for six (6) months after delivery, and offers the customer warranty on material and manufacturing defects, which arise during normal use. This guarantee shall not apply if the fault(s) is/are due to improper use or causes other than material and manufacture faults, or if Berg Hortimotive supplies materials or used goods after consultation with the client or if the cause of the fault(s) cannot be clearly demonstrated.

The guarantee conditions are described in the Dutch "METAALUNIE" CONDITIONS, as recorded in the most recently deposited text. The terms of delivery will be sent on request. For all goods and materials that Berg Hortimotive does not manufacture itself, Berg Hortimotive does not, at any time, offer lengthier guarantee than that provided to it by its supplier. Warranty is "ex-factory"; faulty machines and/or parts need to be delivered freight-paid.

If machines or installations cannot be delivered, the travel and accommodation costs incurred will be borne by the client.

Goods sold and delivered with factory, importer's or wholesale guarantees shall be subject to the warranty provisions laid down by the suppliers.

The hydraulic pump is subject to manufacturer's warranty only if it has an undamaged supplier's safety seal.

Berg Hortimotive takes responsibility for the availability of replacement parts provided that they are available from its suppliers under reasonable conditions.

## 2. **Foreword**

This manual describes the *BENOMIC S*.

This manual provides you with additional information on safety aspects, a description of the working principle of the entire setup, as well as maintenance instructions for the *BENOMIC S*.

It will draw attention to potential hazards and directions for avoiding them.

It is very important to read this manual carefully to learn how to operate and maintain the *BENOMIC S*. By reading and following this manual when using *the BENOMIC S*, you and others will be helped to properly use the *BENOMIC S*, and to prevent personal injury and damage to the machine.

Berg Hortimotive produces safe machines. These machines are designed to the latest standards, according to the CE marking. The user is responsible for the proper use and maintenance of the machine.

# Table of contents

<b>1. DECLARATIONS</b>	<b>3</b>
1.1 COPYRIGHT	3
1.2 LIABILITY	3
1.3 GUARANTEE	4
<b>2. FOREWORD</b>	<b>4</b>
<b>3. INTRODUCTION</b>	<b>7</b>
3.1 GENERAL	7
3.2 SUPPLIERS INFORMATION	7
<b>4. SAFETY</b>	<b>8</b>
4.1 DECLARATION OF SAFETY TERMS	8
4.2 SAFETY INSTRUCTIONS	8
4.3 SAFETY ICONS	11
4.4 OTHER RISKS	12
<b>5. INTENDED USE</b>	<b>13</b>
5.1 SCOPE OF USE	13
5.1.1 <i>Physical operating conditions</i>	13
5.2 SAFETY SYSTEMS	14
5.3 SIGNALLING SYSTEMS	15
5.3.1 <i>The multi-colour indicator (11)</i>	15
5.3.2 <i>The horn</i>	18
5.4 BENOMIC S DESCRIPTION	19
<b>6. TRANSPORT</b>	<b>21</b>
6.1 EXTERNAL TRANSPORT	21
6.2 INTERNAL TRANSPORT	21
<b>7. COMMISSIONING</b>	<b>22</b>
7.1 INSPECTION BEFORE TAKING INTO SERVICE	22
7.2 PIPE-RAIL SYSTEM IN HORTICULTURE	22
7.3 MINIMUM REQUIREMENTS FOR THE PIPE-RAIL SYSTEM	23
7.4 TILT INDICATION	24
7.5 LOAD LIMITER MEASUREMENT SYSTEM	25
7.6 LOAD-HOLDING FUNCTION	25
7.7 SCISSOR-LOCKING DEVICE	25
7.8 EMERGENCY LOWERING VALVE	26
7.9 PIPE DETECTION SENSOR	26
7.10 SPEED LIMITER ON THE CONCRETE PATH	26
7.11 PIPE - CONCRETE PATH TRANSITION	27
<b>8. OPERATION</b>	<b>27</b>
8.1 OPERATION	28
8.1.1 <i>Undercarriage controls</i>	28
8.1.2 <i>Controls on the platform</i>	29
8.2 MOVING THE BENOMIC S ONTO THE MAIN PATH	32
8.2.1 <i>Crop work on a row of plants along a gable path</i>	33
8.3 MOVING THE BENOMIC S ON THE HARVESTING PATH	33
8.3.1 <i>Driving into the harvesting path</i>	33
8.3.2 <i>Driving out of the harvesting path</i>	33
8.4 AUTOMATICALLY DISCONNECT "SLEEP MODE"	34
8.5 OUT OF SERVICE	34
8.6 CLEANING	34
8.7 PROBLEMS, CAUSES AND SOLUTIONS	35
8.8 DISASSEMBLY	37

<b>9. MAINTENANCE AND REPAIRS .....</b>	<b>38</b>
9.1 SPECIALIST MAINTENANCE.....	38
9.2 MAINTENANCE ON, IN OR UNDER THE SCISSOR-UNIT .....	39
9.3 PIPE-RAIL SYSTEM MAINTENANCE .....	39
9.4 CHAIN TIGHTENING.....	40
9.5 CHECK PIPE-RAIL WHEEL WEAR.....	41
<b>10. TECHNICAL SPECIFICATIONS .....</b>	<b>42</b>
10.1 * EXPLANATION OF THE TECHNICAL SPECIFICATIONS .....	43
<b>11. EC DECLARATION OF CONFORMITY .....</b>	<b>44</b>
<b>APPENDIX 1: MAINTENANCE LOGBOOK .....</b>	<b>45</b>
<b>APPENDIX 2: TECHNICAL DRAWINGS.....</b>	<b>46</b>
<b>APPENDIX 3: BATTERY SAFETY SHEET .....</b>	<b>47</b>
<b>APPENDIX 4: CLEANING THE POWDER COAT FINISH .....</b>	<b>52</b>
<b>APPENDIX 5: QUICK START GUIDE.....</b>	<b>53</b>

## **3. Introduction**

### **3.1 General:**

You have made a good choice in purchasing the Berg Hortimotive *BENOMIC S*. You have an excellent tool, which has been carefully constructed and manufactured. This investment will benefit you most if you carefully follow the safety, use, and maintenance instructions detailed in this user manual.

Before commissioning the *BENOMIC S*, please make yourself familiar with this user manual. The safety precautions, instructions and directions given should be observed at all times.

Berg Hortimotive is not liable for damage or indirect damage resulting from failure to follow the instructions and safety precautions set out in this user manual.

The liability of Berg Hortimotive shall also lapse as soon as you or third parties make any modifications to the pipe-rail trolley or accessories without our written permission.

The *BENOMIC S* has been delivered under the "METAALUNIE" (The Dutch METAL-ASSOCIATION) CONDITIONS, as filed at the court of Rotterdam, as they are in accordance with the last text set out there. The terms of delivery will be sent on request. You can also contact the Koninklijke Metaalunie, Postbus 2600, 3430 GA Nieuwegein, The Netherlands.





### **3.2 Suppliers information**

In the event of breakdowns or defects occurring on the *BENOMIC S* please contact your Berg Hortimotive dealer.

## 4. Safety

### 4.1 Declaration of safety terms

Safety terms:

- Danger:**  Indicates serious injury or risk of fatality when ignoring the instructions set out in the user manual.
- Warning:**  Indicates risk of injury when ignoring the instructions set out in the user manual.
- Caution:**  Indicates risk of damage to the machine when ignoring the instructions set out in the user manual.
- ATTENTION:**  Indicates risk of injury when ignoring the instructions set out in the user manual.

### 4.2 Safety Instructions

Please read the following safety precautions carefully.  
After reading the safety instructions, always follow them strictly.  
If the safety precautions are ignored, working with the pipe-rail trolley will be significantly more dangerous, which can cause very serious injury.

**DANGER!** 

- **Read the user manual carefully. Follow the instructions, safety precautions, etc. at all times.**
- **The BENOMIC S is suitable for running on a stable pipe-rail system.**
- **Use the BENOMIC S exclusively on the correct type of pipe-rail system. You must check whether the centre-to-centre pipe-rail gauge corresponds with the pipe-rail trolley, see the icon on the platform.**
- **Never exceed the maximum load capacity of 250 kg\* (for capacities and restrictions see 10.1!)**
  - *One person incl. load (e.g. tools); see the pictogram on the trolley.*
- **Never exceed the sideways applied force of 110 N (towing capacity of 11 kg).**
- **Use the BENOMIC S only for harvesting and crop maintenance in a greenhouse.**
- **Using the BENOMIC S with a tilt exceeding 2° (linearly and/or crosswise) is strictly forbidden.**
- **It is prohibited to transport any unsecured loads with the BENOMIC S! Make sure that the load is placed in the middle and is no higher than 40cm above the platform and is always properly secured.**
- **It is forbidden for more than one person to enter the platform at the same time.**



- **Persons are not permitted to ride on the chassis in any way.**
- **It is forbidden to remove the safety fence.**
- **The use of the safety rail height extender is mandatory if the user is taller than 1.80 metres. Only use an original approved Berg Hortimotive safety guardrail raiser!  
(see 5.2)**
- **It is strictly forbidden to increase the lifting height in whatever way.**
  - *Always stand on the work platform.*
- **Keep a safe distance from fixed and/or moving parts of the greenhouse structure, live electric wiring, and cables and ropes.**
- **Pulling steel or other types of rope/cord/wire and installing protective canvas with the BENOMIC S is not permitted.**
- **Using the BENOMIC S as a crane is not permitted.**
- **Persons or pets are not permitted to enter the operational pathway of a BETOMIC S. Never use more than one pipe-rail trolley on the same path!**
- **All safety shields and protective caps must be fitted and closed during operation of the BENOMIC S.**
- **Additional options, accessories and parts must be manufactured and/or supplied by Berg Hortimotive.**

**Warning!**



- **The BENOMIC S may only be operated when there are no other persons, other than the operator, in the vicinity of the machine.**
- **The BENOMIC S may only be operated by persons of at least 18 years of age who have received thorough instruction on the BENOMIC S, are familiarized with this user manual, fully understand it, and are aware of the hazards.**
- **The BENOMIC S may only be operated once it has been correctly installed on the pipe-rail system.**
- **All personnel working within the active radius of the BENOMIC S must be familiar with the relevant safety rules and precautions that apply to the machine.**
  - *Instructions from the employer.*
- **For safe working at heights, Berg Hortimotive recommends the use of safety belts that comply with the EN358 standard. The BENOMIC S is equipped with two safety belt anchor points and anchor rail for securing the safety belts (see 5.2).**
  - *Instructions from the employer.*
- **Repairs on the BENOMIC S may only be carried out by personnel instructed by Berg Hortimotive.**

- **When servicing the scissors, support it at all times using the scissor-lock (see 9.2).**
- **Never carry out work on the BENOMIC S while someone else is operating it. Always switch it off using the main switch, and remove the charging plug from the trolley before carrying out maintenance.**
- **Check the BENOMIC S every day for defects and give it regular maintenance, see chapter 9: Maintenance.**
- **Clean the controls and safety pictograms regularly and in good time.**
  - *Operating functions and safety pictograms must be visible at all times.*
- **The BENOMIC S must always be switched off after use, using the main switch.**
- **Never leave the BENOMIC S unattended,**
  - *unless the key is removed from the main switch.*
- **It is forbidden to make any modifications/alterations to the BENOMIC S without written permission from Berg Hortimotive**
- **When leaving a track, first stop and check whether anybody is standing in the direct vicinity before continuing onto the concrete path.**
- **Before going onto a track, ensure that there are no obstacles such as plant remains, etc. lying on the rail.**
- **Never clean the BENOMIC S with a water hose, high-pressure water gun or steam cleaner.**
- **When moving the BENOMIC S, other than on the pipe-rail, or crossing on a concrete path, the platform has to be at its lowest position.**
- **The BENOMIC S is besides driving on a pipe rail system, also suitable for driving on a flat paved floor (concrete), which is rough enough to be able to drive and stop safely. The surface condition must comply with NEN2743: 2003 Concrete floors.**
- **Never use the BENOMIC S outdoors or on the public road.**
- **Leaving a trolley that is not completely at its lowest position is not permitted.**
- **Follow the battery safety specifications, see Appendix 3.**
- **Beware of feet and toes when operating the lifter on the BENOMIC S! The trolley moves a few centimetres forwards when setting down!**
- **Wearing shoes with safety toecaps (minimum S1) is mandatory.**
- **Always remove the charging plug before using the BENOMIC S.**

**Attention!**

- **Keep the workplace tidy.**  
*An untidy working area leads to hazardous situations.*
- **Be focused.**  
*Always maintain the appropriate level of concentration when operating the pipe-rail trolley. Do not operate the BENOMIC S when unable to concentrate properly, or when using medication that could impair your reaction times when operating machinery or participating in traffic.*

### 4.3 Safety icons

The *BENOMIC S* carries a few safety icons. These icons should alert the user to potential hazards or hazardous situations. Observe the warnings at all times and contact your supplier if the hazard indicated by the icon seems unclear.

Always make sure that the icons remain visible and undamaged!

The operator of the *BENOMIC S* must have read and understood this manual before using it. If the user does not understand the warnings in the manual or on the machine (e.g. because he/she speaks a different language), all instructions, hazards, warnings and functions should be explained to the user by a responsible person so that the user can clearly understand them.



Use only indoors (in the greenhouse)

Mass of the machine in kg

Suitable for the indicated pipe diameter with minimum wall thickness

Suitable for the indicated centre-to-centre (gauge) pipe-rail system size

Maximum tilt 2°

Maximum lateral applied force in Newton (kg x 10)

Maximum support distance 1000 mm

Maximum total load in kg (maximum one person + secured load)

**The values depend on the type of *BENOMIC S*!**



Pay attention to the lowering platform!

Always use the scissors locking device when working under or on the scissors!

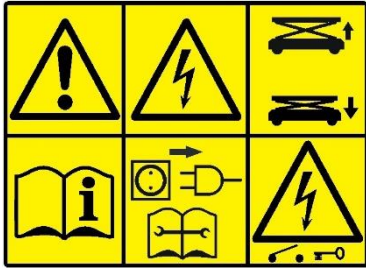

WARNING! Read the user manual before use!

WARNING! During maintenance, first isolate the power (Switch off main switch) and consult the manual

Upwards = scissors up, Downwards = scissors down

Main switch (power): key vertical = ON, key horizontal = OFF

The key can be removed by continuing to turn in the off position.



Warning! Dangerous chemical battery: explosive gas and corrosive battery acid!



WARNING; danger of entrapment!

Keep your hands away from the scissor parts!

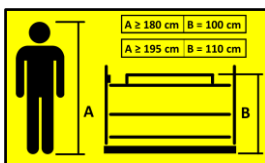

Height of the railing depends on the length of the user

#### 4.4 Other risks

Despite the best possible design, the use of risk-reducing resources and warnings against the hazards on the machine and in the manual, hazardous situations may still occur.

Watch out for and avoid:

- The risk of crushing hands, fingers, arms and head between the scissor parts!
- The risk of crushing under the trolley when using the lifting mechanism for setting down or lifting!
- The risk that trolley may topple if used on an unsuitable pipe-rail system!
- The trolley can topple if the maximum laden weight or applied force limits are exceeded!
- Users taller than 1.80 metres can lose their balance if they do not use the obligatory safety rail height extender!

## 5. Intended Use

### 5.1 Scope of use

The *BENOMIC S* is intended for professional use in the greenhouse horticulture sector. The controls may only be operated by one person with a minimum age of 18 years who has received thorough instruction on operation of the *BENOMIC S*. This person must fully understand the safety instructions and this manual.

The *BENOMIC S* is a pipe-rail trolley, which runs on a pipe-rail system that meets the minimum requirements of paragraph 7.3 and is intended as an aid in harvesting, caring for and/or maintaining the crops in a greenhouse. Use of the *BENOMIC S* for any other purposes is strictly forbidden. The maximum load may consist of one person plus a secured load, of which the combined weight should not exceed 250 kg\*. The trolley may only be operated once it has been correctly installed on the pipe-rail system. Take extra care when the scissors drop so that no persons or objects are trapped under or between the scissor-unit. Always walk alongside the trolley, therefore not on the chassis when transporting it over the main path.

\* Stability tests have shown that with unfavourable combinations of pipe-rail type and the support distance of the pipe-rail system, constraints must be applied for the maximum permissible load. See 10.1 Explanation of the technical specifications.

#### 5.1.1 Physical operating conditions

Ambient temperature,	
Transport & Storage:	5 to +40 degrees Celsius
Working:	5 to +40 degrees Celsius
Rel. Humidity (RH):	0% to 90%, <u>not condensing</u>
Lighting:	Normal ambient lighting.

The machine is not designed to be used outdoors.  
The machine is not suitable for operating in explosive atmospheres.

## 5.2 Safety systems

The *BENOMIC S* series is equipped with the following safety systems, which will be described in chapter 7 (Commissioning) and chapter 8.1 (Operation).

- Running and lifting restriction when tilted (see 7.4)
- Load limiter measurement system (see 7.5)
- Load-holding function (see 7.6)
- Scissor-locking device (see 7.7)
- Emergency lowering control (see 7.8)
- Pipe detection sensor (see 7.9)
- Speed limiter on the concrete path (see 7.10)
- Pipe-rail to concrete path transition (see 7.11)
- Emergency stop (see 8.1.2)
- Lowering the platform (see 8.1.2)
- Two-handed control (see 8.1.2)
- Inadvertent foot pedal operation (8.1.1)
- Safety belt anchor points & anchor rings\*
- Guardrail raisers\*\*

\* & \*\* The regulations for the use of certain safety devices may differ from country to country, always consult the local safety authorities before use, these regulations are authoritative!

\* In general, the use of safety belts is compulsory in many countries from a working height of 2.50 metres. There are two possibilities for attaching a safety belt:

- On the anchor rails, giving more freedom of movement (not always allowed!)
- At the anchor points

\*\* The use of guardrail braces depends on the height of the user. For employees taller than 1.80 metres, raising the standard guardrail is mandatory!

- **Always work according to the local safety regulations!**
- **Manipulation of safety systems is strictly prohibited!**
- **Additional options, accessories and parts must be manufactured and/or supplied by Berg Hortimotive.**



### 5.3 Signalling systems

In order to alert the user to changing status of the *BENOMIC S* during use, a multi-colour indicator (11) and horn are used.

#### 5.3.1 The multi-colour indicator (11)

The multi-colour indicator (11) is located on the platform control, for this refer to chapter 8.1.2.

The visual signalling is divided into seven indication levels:

- |                                  |                        |
|----------------------------------|------------------------|
| 1. Safe & alert status           | Colour Green or Orange |
| 2. Acute danger                  | Colour Red             |
| 3. Indirect danger               | Colour Red-Orange      |
| 4. Function monitoring (sensors) | Colour Red-Blue        |
| 5. Reset emergency stop          | Colour Blue            |
| 6. Cruise control                | Colour Light-Blue      |
| 7. Disinfection                  | Colour Purple          |

#### Safe & alert status

The indicator displays a status or flash pattern in the colours Green, Orange

Green:	Safety status:	Limitation:	Solution:
Off	Benomic S is powered off	Is off	
On	BENOMIC S is on, in safe status	None	
Flashing 2x	Start-up / standby, flash indicates the number of scissors	Is on standby	Press horn / reset button (2 or 10) Stops automatically
Flashing 3x	Start-up / standby, flash indicates the number of scissors	Is on standby	Press horn/reset button (2 or 10) Stops automatically
Flashing 4x	Start-up / standby, flash indicates the number of scissors	Is on standby	Press horn / reset button (2 or 10) Stops automatically

Orange:	Safety status:	Limitation:	Solution:
Flashing slowly + bleeping	Tilt warning "attention" with raised platform		level the pipe-rail system (see 7.3)

### Acute hazard

The indicator displays a Red blinking pattern:

<b>Red:</b>	Safety status:	Limitation:	Solution:
On, short	Starting up	Wait 1 sec.	Turns itself off
On & Bleeping	Tilt warning "critical" with raised platform	Platform raised Running stops	Lower platform level the pipe-rail system (see 7.3)
Flashing 1x & Bleeping	Emergency stop used	Operation stopped	Unlock if danger averted
Flashing 2x & Bleeping	Batteries empty	Platform raised Lift wheels Speed limiter	Fully charge batteries
Flashing 3x	Tilt warning "critical" with lowered platform	Platform raised	level the pipe-rail system (see 7.3)
Flashing 4x	Load limiter	Platform raised Run with raised platform	Reduce load Lower platform height
Flashing 5x	Pipe-rail sensor malfunction	Platform raised Lift wheels Run with platform raised Speed limiter	Consult your dealer

### Indirect danger

The indicator displays a Red-Orange blinking pattern:  
This blinking pattern consists of two colours.

<b>Red Orange:</b>	Safety status:	Limitation:	Solution:
Flashing 1x	Speed too high	Running stops	Switch Benomic S off and on, Consult your dealer
Flashing 2x	Tilt sensor signal is absent with low platform	Run with platform raised	Lower platform completely, Consult your dealer
Flashing 3x	Height sensor signal absent	Platform raised Platform down only slowly	Lower platform completely, Consult your dealer
Flashing 4x	Load limiter in combination with platform height	Running stopped	Reduce load <150 kg, Lower platform <2.5 m
Flashing 5x	Load sensor signal absent	Platform raised Run with raised platform	Consult your dealer
Flashing 6x	Speed limiter (running pulses absent)	Running stops Speed limiter	Speed reduction active on restarting Consult your dealer



### Function monitoring (sensors)

The indicator displays a Red-Blue blinking pattern:  
This blinking pattern consists of two colours.

<b>Red Blue:</b>	Safety status:	Limitation:	Solution:
Flashing 1x	Both sensors of wheel lift system active	Platform raised Running stops	Consult your dealer
Flashing 2x	Wheel lift system time too long	Platform raised Running stops	Operate the lift-wheel system again, Consult your dealer
Flashing 3x	Wheel lift system sensors status spontaneously changed	Platform raised Running stops	Operate wheel lift system again, Consult your dealer
Flashing 4x	Lift time too long / platform lowers	Platform stops	Operate again

### Reset emergency stop

The indicator displays a Blue blinking pattern:

<b>Blue:</b>	Action or Safety status:	Limitation:	Solution:
Flashing	Emergency stop released	Benomic S stopped	Press reset button (2 or 10)
Flashing	Button operated at power-up	Does not enter operating state	Continues to flash blue, deactivate operated button

### Cruise control

The indicator displays a Light-Blue blinking pattern:

<b>Light Blue:</b>	Action or Safety status:	Limitation:	Solution:
On	Cruise control active	Maximum speed limited 30 m/min.	Stops by, a short press on the foot pedal
Flashing	Cruise control on standby	Does not drive yet	Press the foot pedal shortly

### Disinfection

The indicator displays a Purple blinking pattern:

<b>Purple:</b>	Action or Safety status:	Limitation:	Solution:
On	Disinfection * advance notice	None	Disinfect hands
Flashing slowly	Disinfection * time elapsed	Running stops	Disinfect hands

\* A disinfectant fluid container for the hands can be supplied as an option for the *BENOMIC S*, ask dealer for the possibilities.

### 5.3.2 The horn

The acoustic warning gives the user feedback on the action that is being performed, or a changing safety status.

Horn signal:	Action or Safety status:	Limitation:	Status or Solution:
1x bleep	Press horn / reset button (2 or 10)	None	The Benomic S is on and ready for use
bleep tone	Press horn / reset button (10)	None	Horn is active while being pressed
1x bleep per 3 sec	Emergency stop used	Operation stopped	Unlock if danger averted
2x bleep per 3 sec	Batteries empty	Platform raised, Lift wheels, Speed	Fully charge batteries
5x short bleep	Incorrect operation, function not possible Button operated at power-up	The required action will not be executed  Does not enter operating state	Execute an operation that is possible (safe). (E.g. platform down) Continues to flash blue, deactivate operated button
1x bleep per 0.5 sec	When lowering the platform in the last meter	Platform descends slowly	Platform is lower than 1 metre, Beware of entrapment.
Slow bleeping	Tilt warning "attention" with raised platform	Speed (above height 250 cm)	level the pipe-rail system (see 7.3)
Fast bleeping	Critical tilt with raised platform	Platform raised Running stops	Platform lowered, level the pipe-rail system (see 7.3)

### 5.4 *BENOMIC S* description

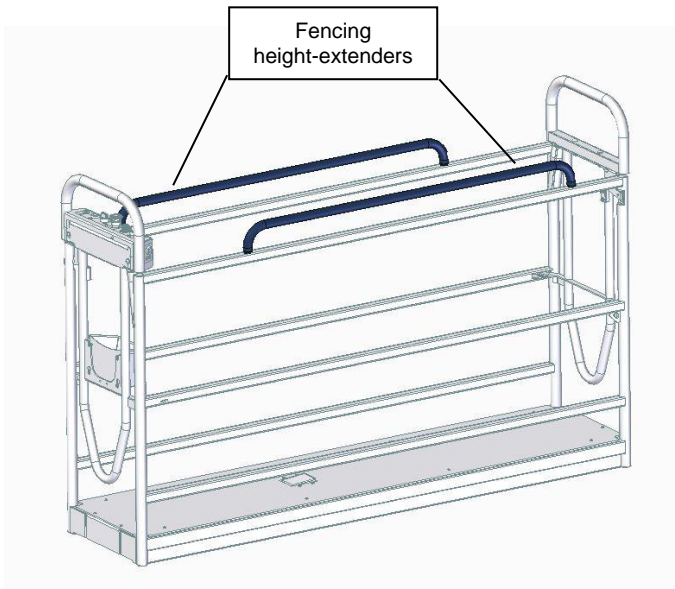
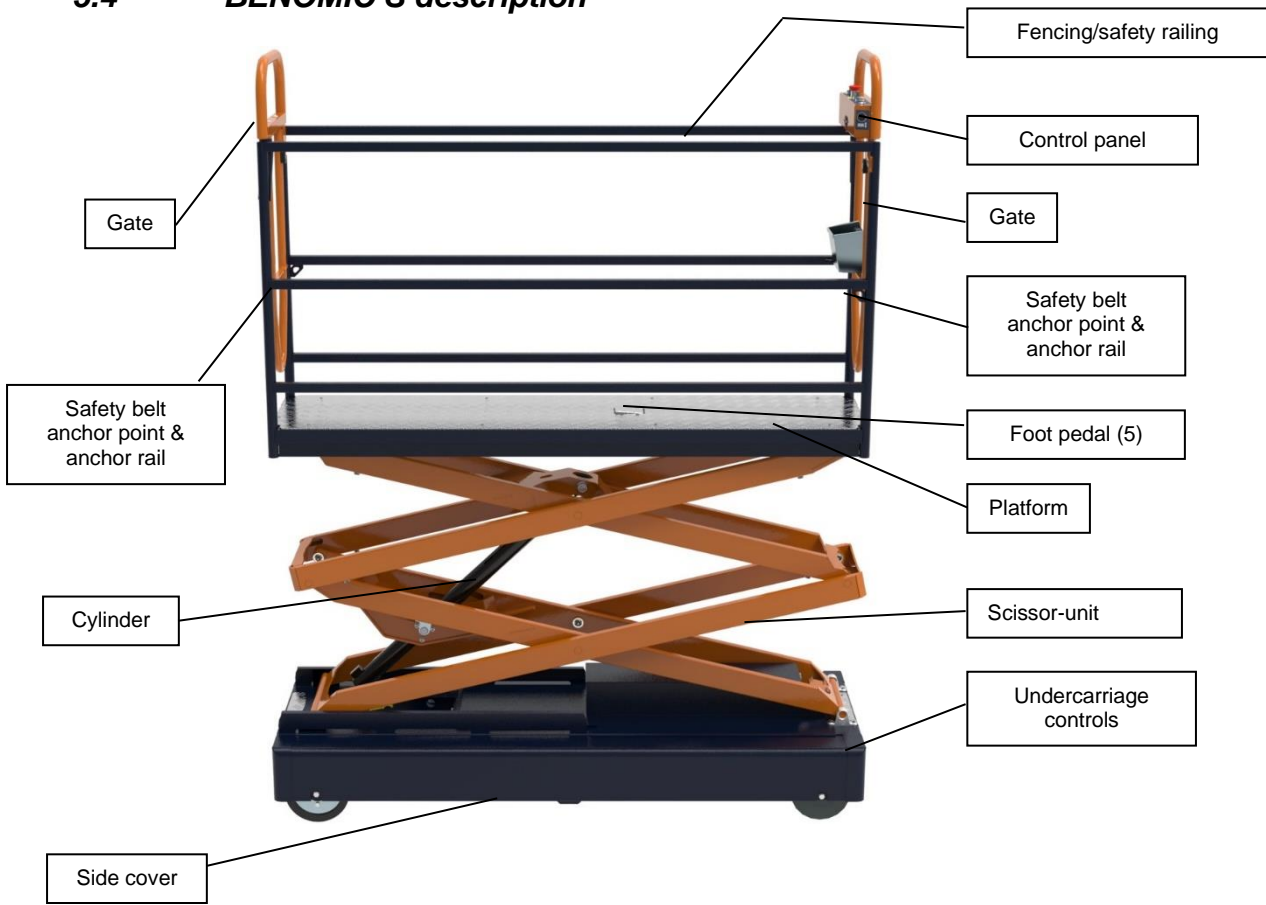

**NOTE:**  
Fencing height-extendors are supplied/assembled as standard for the French market.

Figure 5.1; Names of the components on the upper-side of the *BENOMIC S*

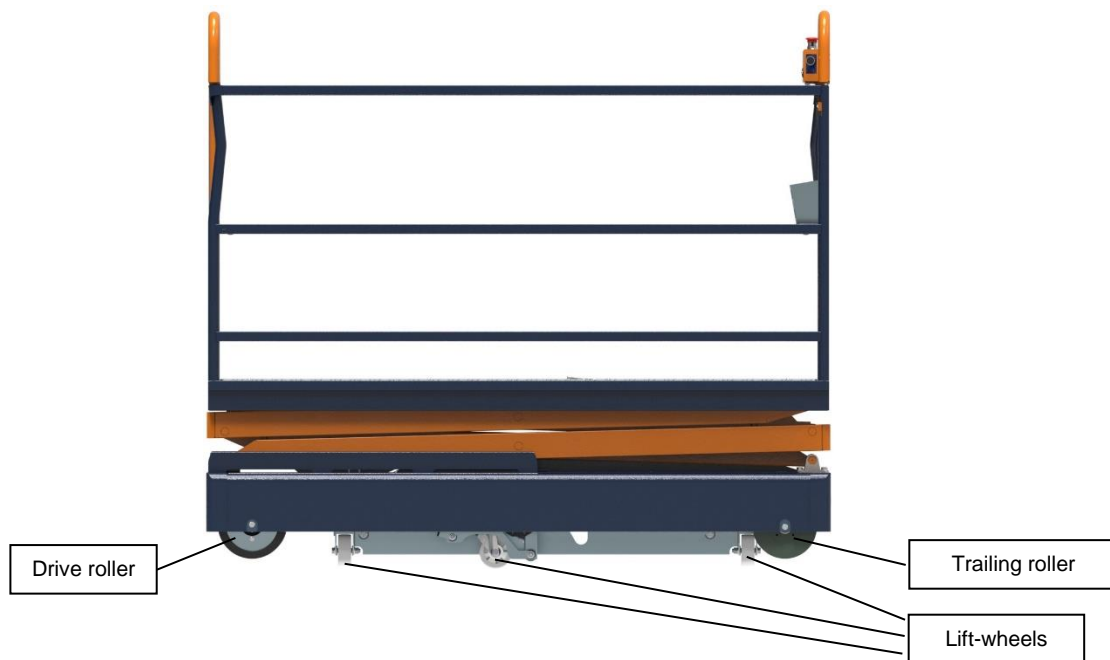

Figure 5.2; Names of the components on the under-side of the BENOMIC S

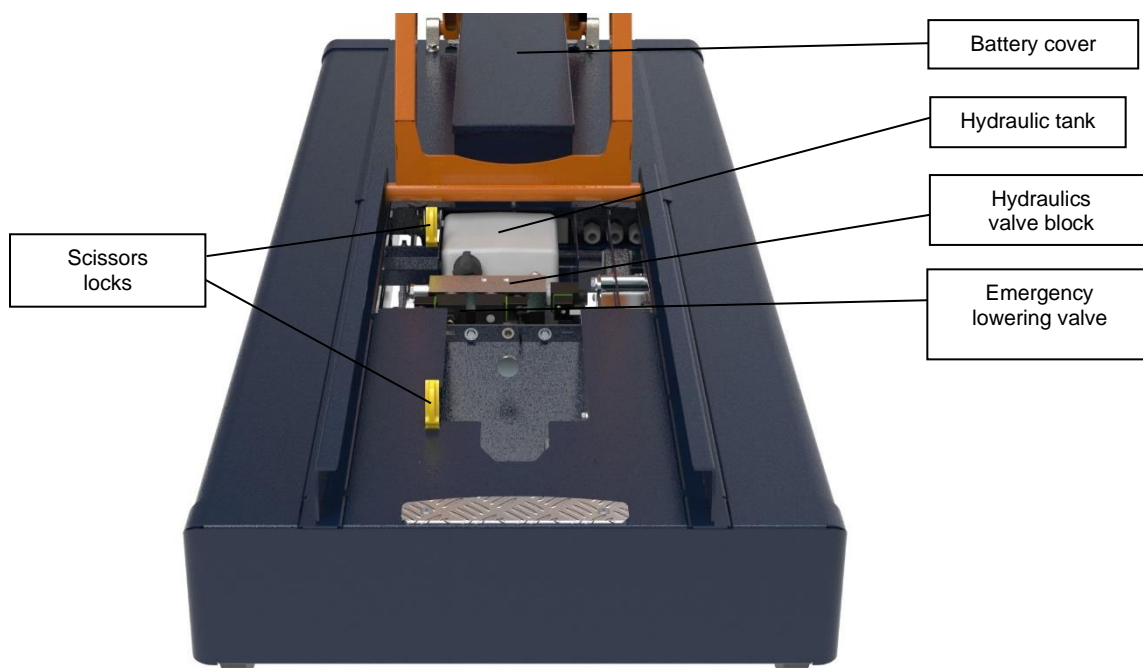

Figure 5.3; Names of the components on the underside of the BENOMIC S

## 6. Transport

### 6.1 External transport

Please follow the procedure set out below if you need to transport the *BENOMIC S*:

1. Lower the platform completely.
2. Make sure the lift-wheels are retracted, so that the trolley is resting on its flange rollers.
3. Set the direction and speed control to position 0.
4. Switch off the *BENOMIC S* with the main switch (turn the red key to the horizontal position).
5. Properly secure the *BENOMIC S* to prevent it from sliding, rolling or toppling over.
6. Ensure that the *BENOMIC S* remains dry and frost-free during transportation.
7. After having arrived at its destination, the *BENOMIC S* must be started up in accordance with the points described in chapter 7.1.

### 6.2 Internal transport

The *BENOMIC S* may also be transported indoors (in the greenhouse). The preferred method here is to drive the trolley on its flange wheels or lift-wheels (see 8.2), but it can also be moved with a forklift. To move it with a forklift, proceed as follows:

1. Lower the platform fully.
2. The lift-wheels are retracted, so that the trolley is resting on the flange rollers.
3. Switch off the *BENOMIC S* with the main switch (turn the red key to the horizontal position).
4. Position the forklift forks as far apart as possible and insert them as far as possible under the trolley, keeping them centred.
5. On the other side, check that the forks protrude far enough and are positioned centrally under the *BENOMIC S*.
6. Secure the *BENOMIC S* to the load backrest on the forklift truck, so that the trolley cannot slide or tilt with respect to its position on the forks.
7. Lift the *BENOMIC S* from the ground carefully, and no higher than necessary.

#### **Attention!**



- **Secure the *BENOMIC S* to the rack of the forklift truck with a suitable strap!**
- **Never lift higher than necessary!**
- **Make sure that the forklift truck is suitable for lifting at least 600 kg!**
- **Remove loose parts from the platform before lifting!**
- **Drive slowly and carefully!**

## 7. Commissioning

The *BENOMIC S* has been specially designed for running on a stable pipe-rail system (see 7.2 and 7.3). Berg Hortimotive checked the pipe-rail trolley for proper functioning and safety before it left the factory. The items described in article 7.1 must be inspected prior to taking the *BENOMIC S* into service.

### 7.1 *Inspection before taking into service*

The following points must be checked before putting the *BENOMIC S* into service:

- No loose electrical connections (all the functions and buttons work properly);
- No damaged cables and/or hoses (leakage).
- The drive and trailing flange rollers and lift-wheels must be undamaged, and they should rotate smoothly;
- The battery should be charged (see Battery indication 8.1.2 No.13).
- Ensure there is no general mechanical damage (with special attention to the scissor components).
- No damage to or impaired visibility of the control components, pictograms and symbols.
- Presence of safety guards and covers.
- The scissor mounting on the undercarriage and the fence on the scissor-lift platform.
- Mounted safety rail height extender for users taller than 1.80 metres.
- Proper working of the lift-system.
- Indicator and horn operation as described in Signalling systems (5.3) and Controls (8.1)
- Special attention should be paid to the periodic checks stated in the following paragraphs of this chapter. These checks should be carried out at least monthly or yearly, according to the stipulation!

### 7.2 *Pipe-rail system in horticulture*

The *BENOMIC S* has been designed to run on a stable pipe-rail system. This means that each path between the crops has a track comprising two pipes of the same diameter with a fixed width between them (centre-to-centre (c.t.c.) size). The pipes are often used as heating pipes and are supported with fixed spacing between them.

### 7.3 *Minimum requirements for the pipe-rail system*

Stability tests have shown that with unfavourable combinations of pipe-rail type and support spacing on the pipe-rail system, constraints must be applied for the maximum permissible load. See 10.1 Explanation of the technical specifications.

The *BENOMIC S* is based on a pipe-rail system as described in the Dutch ARBO catalogue. Briefly, the following key principles apply:

- A pipe-rail system means that each path between the crops has a track comprising two pipes of the same diameter and with a fixed width between them (centre-to-centre (c.t.c.) size).
- The pipes are often used as heating pipes and are supported with fixed spacing between them. These supports are subject to a minimum requirement of a 1.5 mm thick steel base plate (with a stiffening profile), a minimum width of 115 mm and with enough length to ensure that the base plate protrudes at least 70 mm from the two upright supports that carry the pipes.
- The pipes must be steel quality (S235) with pipe diameter and wall thickness of 51/2,25 mm or 45/2 mm respectively.
- The pipes must be anchored into the concrete path. They must not be free-standing!
- Regardless of the pipe-rail system, the requirement is that a maximum support spacing of 1 metre is applied in the last 10 meters!
- At the end of the pipes (in front of the façade), there should be a welded stop with a height of at least 5 cm. These should be checked once for every change of season to ensure that the stops are not flattened, bent, skewed or cracked.
- The surface under the pipe-rail system should be sufficiently load-bearing. This is based on a top-layer cone penetration test value of more than 0.4 Mpa (62 psi). It is important to keep the surface dry, flat and therefore hard. Soft/wet spots must be repaired and any subsidence must be permanently resolved.
- The pipe-rail system must have a maximum tilt of 2 degrees, both lengthwise and width. This makes it important to check the pipe-rail periodically.

## 7.4 Tilt indication

The *BENOMIC S* is equipped with a sensor/alarm for both the lengthwise and lateral tilt, with a visual warning signal, which may be supplemented with an acoustic warning signal. For a complete overview of the visual and acoustic warning signals, refer to chapter 5.3.

The operation of the tilt indication should be checked monthly.

Put the *BENOMIC S* on a flat concrete floor, and operate the platform upwards to about 120 cm, using the scissor-control service button (2 and 3) as described in 8.1.1. Then put a pallet jack on one side under the side cover of the *BENOMIC S*, increasing the tilt step by step. During this test, the following acoustic signals should be heard:

- Slow bleeping; there is a skew position; be extra alert!
- Rapid bleeping; the tilt is critical; take action!

Establish whether the acoustic signals can be heard or not during this check; if so, the tilt indication is approved.

**It is forbidden to work with the *BENOMIC S* if the tilt indication is not working! Consult your dealer if the tilt indication does not pass the periodic inspection!**

the *BENOMIC S* reacts in the following order, if the pipes are not properly levelled;

### **If the platform is higher than 120cm:**

When the platform is tilted, the orange indicator (11) flashes slowly, the horn beeps slowly. Driving with the platform high is possible, be extra careful!

At a critical misalignment, the red indicator (11) lights up, the horn beeps rapidly and driving is stopped immediately.

Proceed as follows:

- Lower the platform
- The horn stops beeping
- The red indicator (11) blinks cyclically 3 times
- Drive back until the green indicator is fully lit again
- Follow the recommendations below immediately

### **Follow-up action after exceeding the tilt:**

The pipe rail system must be levelled before work may be resumed. First test the prepared piece of rail by driving over it with the platform in the lowest position, at low speed. If this gives no problems, test a second time with the platform raised and at minimum speed. If no problems occur, normal operations can be resumed. Make sure you have a solid and durable solution to the skew of the rails! **Use a sound and sustainable solution for resolving misalignment of the rails!**

### **If the platform is lower than 120cm:**

In case of critical misalignment, only the red indicator (11) will flash 3 times repeatedly, the horn does not beep yet and driving remains possible.

In this situation the 'follow-up action after exceeding the skew' is necessary. Later in the season (if the platform is higher than 120cm) the *BENOMIC S* will stop driving at this position if the pipe rail system is still too skewed.

#### **Caution!**

By taking this preventive action, a future unsafe situation is prevented.





## **7.5 Load limiter measurement system**

The *BENOMIC S* series is equipped with a load limiting system that prevents the work platform from being used when too heavily loaded. If the load exceeds that indicated on the safety sticker (4.3), the work platform will not go up and the indicator (11) will flash the red alarm code 4x. Running is only possible in the low position.

The operation of the load limiting system should be checked monthly. Put the *BENOMIC S* on a flat concrete floor, and operate the platform upwards with the scissor-control service button (3), as described in 8.1.1. The platform will move upwards. Lower the platform again and put a weight of >50 kg on the platform. Then operate the platform upwards with the scissor-control service button (3) and establish that the platform stops rising within 50 cm, after which five short beep tones will be heard. The load limiting system is thus approved.

It is forbidden to work with the *BENOMIC S* if the platform does not stop as described above!

Consult your dealer if the load limiting system does not pass this periodic inspection!

## **7.6 Load-holding function**

If the hydraulic hose is punctured when using the work platform in the raised position, the 'load-holding function' will immediately operate. The work platform stops lowering, after which the operator has to drive it back to the main path slowly. Stay calm, get help, and contact your dealer.

## **7.7 Scissor-locking device**

In order to be able to perform work and maintenance safely when the work platform is raised, the scissor-locking device must always be activated. For this, see chapter 9.2.

## 7.8 Emergency lowering valve

The emergency lowering valve is located under the cover plate, which is under the scissor structure at the location of the yellow sticker shown below. If the scissors no longer go down with the controls on the platform (9) and not with the controls on the leading edge of the *BENOMIC S* (2 & 3), the emergency lowering valve lever must be put in the direction of the arrow.

**Beware of trapping your hands, arms or head between the scissors parts or under the platform!**

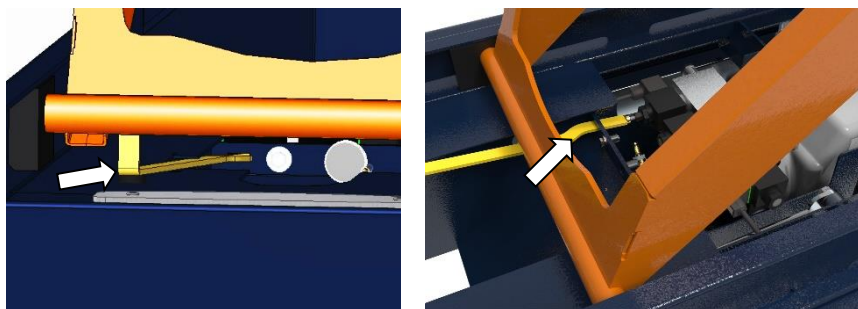

Fig. 7.1; Illustration of the emergency lowering valve control

### Attention!

**Beware of trapping your hands, arms and head between the scissors parts or under the platform! Use this function only in an emergency!**



## 7.9 Pipe detection sensor

To protect the user against incorrect use, the *BENOMIC S* is fitted with a pipe-rail detection sensor. Depending on where the *BENOMIC S* is located, functions are automatically limited on the pipes in a harvesting path or on the concrete path. See 7.10, 7.11 and 8.3.1 & 8.3.2.

The operation of the pipe-rail detection sensor is automatically tested when the *BENOMIC S* is turned on.

## 7.10 Speed limiter on the concrete path

The speed on the concrete path is limited to 83 m/min., it is however advisable to set a lower speed with the speed control knob (7).

The speed on the concrete path is limited to a maximum of 30 m/min if the working platform is higher than 80 cm, this situation occurs when crossing the main path (central path) or in crop work along a gable path.

## 7.11 Pipe - concrete path transition

With the pipe-rail (harvesting path) to concrete path transition, the *BENOMIC S* automatically stops running when the pipe-rail sensor (in the middle of the trolley) no longer detects any pipe-rail. However, it is recommended that the user knows when the concrete path is approached in order to reduce the speed and stop in time. See also 8.3.2.

## 8. Operation

Make sure that you are familiar with the *BENOMIC S* and its controls. Make sure that the person operating the *BENOMIC S* has received instructions regarding the pipe-rail trolley and its safety precautions, and has read and understood this manual.

- The *BENOMIC S* may only be operated if one is sure that no one is in the immediate vicinity of the pipe-rail trolley.
- Before use, remove crop remains and other waste or obstacles from the pipe-rail system.
- Keep the *BENOMIC S* clean, and regularly remove dirt accumulations. To clean the vehicle, turn it off by removing the key from the ignition.
- After using the *BENOMIC S*, remove the key from the ignition switch.
- Maintain the *BENOMIC S* regularly and place it in a dry, frost-free place if it is not used for a longer period.

**Charge the batteries if only 1-2 orange LEDs illuminate on the battery status indicator. If this level is reached during work activities, you can usually continue until the end of the day. If an acoustic signal repeatedly gives two beeps, the *BENOMIC S* should be recharged immediately. Charging must not be interrupted until the charge indicator shows that it is fully charged, after approximately 12 hours. (See the battery charger manual for this). Brief charging during coffee and lunch breaks must be avoided as this can cause serious damage to the batteries. Charging too soon (when the battery status indicator has more than three orange LEDs) will result in a shorter battery lifespan because the batteries wear with each charging cycle, avoid unnecessary charging!**

**Explosive gas is released when the batteries are being charged. Keep sparks, naked flames or cigarettes away from batteries. Ensure that the place where batteries are charged and/or stored is well ventilated. Ensure that no metal objects can fall on the batteries as this could cause short circuits or sparks which in their turn could lead to an explosion.**



## 8.1 Operation

### 8.1.1 Undercarriage controls

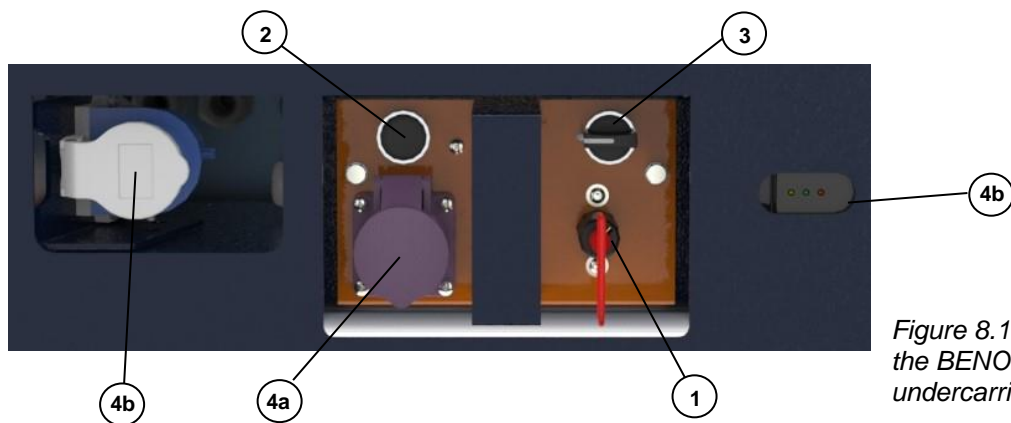

Figure 8.1; Controls on the BENOMIC S350 undercarriage

#### 1. MAIN SWITCH / EMERGENCY STOP

The *BENOMIC S* can be switched on and off with the main switch. If the red key is in the running direction (vertical), then the trolley is ON, if the red key is perpendicular to the running direction (horizontal), then the trolley is OFF. The *BENOMIC S* is activated after a reset button (2/10) is operated. When the *BENOMIC S* is switched on, a bleep signal will sound and the indicator will flash Red once and then illuminate in Green/flashing, the battery status indicator will also start up (see Platform Controls). When the *BENOMIC S* is not being used or charged, the red key should be taken out of the ignition. The main switch also serves as an emergency stop. If the key is positioned horizontally, the trolley is completely switched off.

#### 2. SCISSOR UNLOCK SWITCH KNOB/RESET

The release button (2) releases the service button (3) for use, this button must be pressed continuously during the upward or downward movement.

In addition the unlock/reset button (2) activates *the BENOMIC S* after the main switch (1) is moved into the vertical position.

#### 3. SCISSOR-CONTROL SERVICE BUTTON

The scissor-control selector switch allows the platform to be raised or lowered without standing on it. The *BENOMIC S* should not be on the pipe-rails for this operation! Keep the release button (2) pressed and turn the service button (3) clockwise (white stripe up) and the platform will rise as long as the buttons are operated. Keep the release button (2) pressed and turn the service button (3), white stripe downwards, and the platform will lower as long as the button is operated.

#### Attention!



- **Ensure that no persons or objects can get under or between the scissors construction while lowering!**
- **An acoustic signal will sound when the platform slowly falls in the last bit!**
- **Provide adequate space above the *BENOMIC S* to allow the scissors to go up!**
- **Do not use the buttons if anyone is on the platform!**

#### 4a. CHARGING PLUG SOCKET

You can use this socket to charge the batteries. Make sure the plug is removed before the *BENOMIC S* is put into operation! *Always remove the charging plug during maintenance.* Only a suitable charger should be used - see the specifications on the charger.

#### 4b. CHARGING PLUG SOCKET (option!)

This charging plug socket is mounted only when the *BENOMIC S* features an internal battery charger. A 230 V extension cable should be connected to this if the batteries need charging.

#### 5. FOOT PEDAL

A foot pedal (5) is mounted in the platform (page 11), the *BENOMIC S* will run in the desired direction for as long as the foot pedal is operated.

You will hear 5 short beeps if a safety system engages and signals that the trolley may not be driven.

#### 8.1.2 Controls on the platform

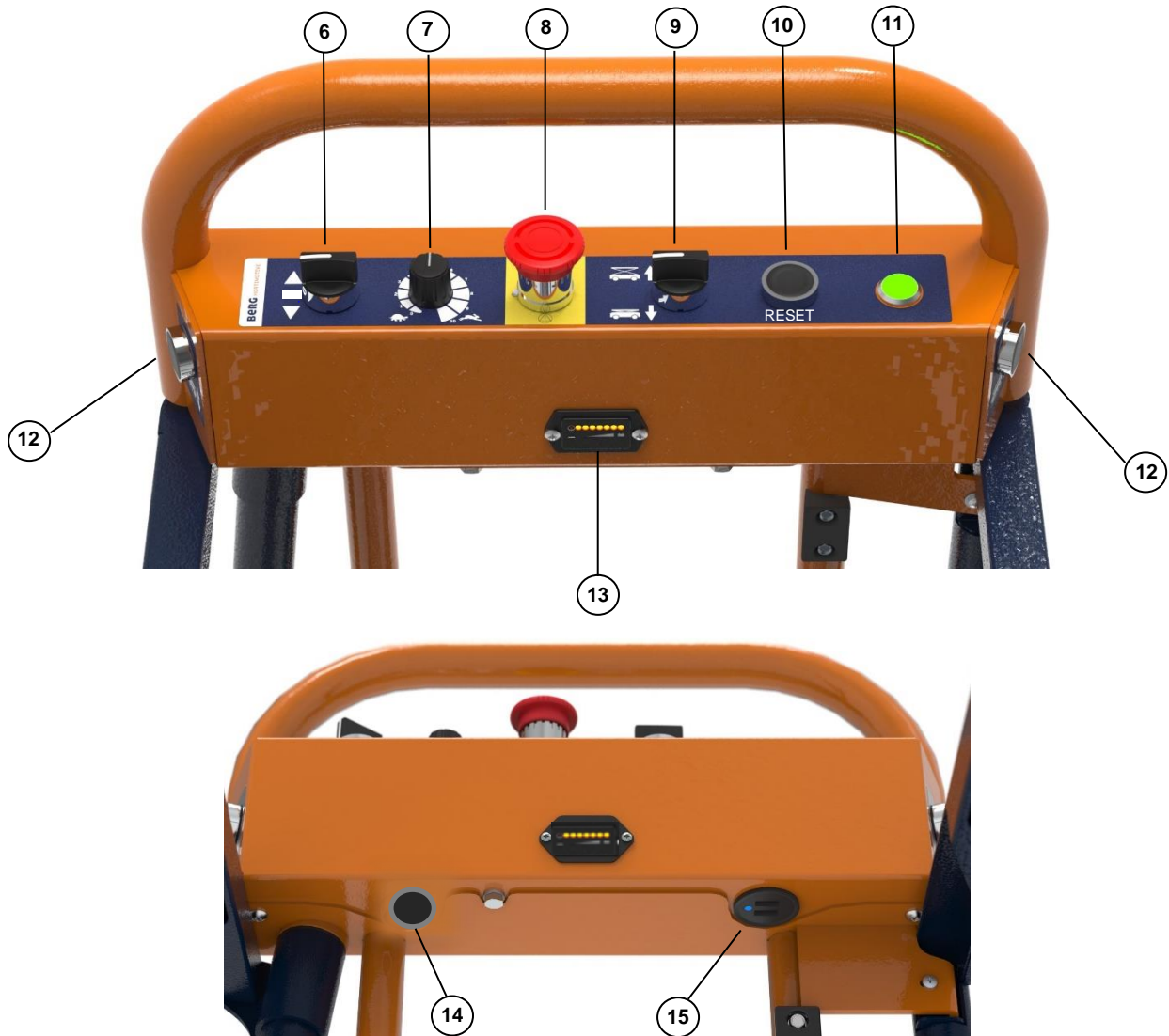

Figure 8.2; Top and bottom control consoles

## 6. DIRECTION OF TRAVEL REVERSE SWITCH

The direction of travel selected is determined by setting the selector to the desired direction.

## 7. SPEED CONTROL KNOB

0 = idle 10 = maximum speed

## 8. EMERGENCY STOP

Only use in case of emergency! The main switch (1) must be used for switching off.

- Press = stop
- Turn-pull out = release

When an emergency stop is activated, you will hear an acoustic signal (1 bleep every 3 seconds) for 1 minute, and the Red indicator will blink slowly. After the minute of sound, only the red signal lamp will continue flashing slowly.

After 2 minutes, the *BENOMIC S* goes into a "sleep mode", the signal lamp (11) and the battery condition meter (13) are no longer illuminated.

This sleep mode is only activated if the work platform is lower than 80 cm.

If the emergency stop is released within two minutes, the signal lamp will flash blue, then press HORN/RESET button (10) briefly to re-activate the *BENOMIC S* for operation.

### Starting up after engaging the emergency stop or "sleep mode" active



Never release an emergency stop (reset) if you do not know who engaged the emergency stop and why.

Release the emergency stop only when the dangerous situation has been averted!

Then press the HORN/RESET button (10) to activate the *BENOMIC S* for use. (also see 1. MAIN SWITCH/EMERGENCY STOP)

## 9. WORK PLATFORM DOWN/UP, ROTARY SWITCH

The rotary switch can be used to lower or raise the work platform when the pipe-rail trolley is completely installed on the rails. The platform will lower as long as the knob is turned counter-clockwise.

***Beware of people or objects in the vicinity of the scissors while lowering!  
An acoustic signal will sound while the platform slowly lowers during the final stage of lowering!***



The scissors will rise to a maximum platform height as long as the button is turned up clockwise. The maximum height is 3.5 metres with double scissors.

Release the button as soon as the work platform has reached the maximum height!

## 10. HORN / RESET

Use the horn if you want to warn someone, an acoustic signal is audible as long as the push-button is pressed.

Use the horn / reset button (10) to activate the *BENOMIC S*, 'reset' after using the main switch (1) or the emergency stop (8). After this operation, the indicator (11) will light up Green continuously when the *BENOMIC S* is in a safe status, it is then ready for use. The horn 'beeper' also gives a feedback to the user if the safety status of the *BENOMIC S* changes. For this, see 5.3.2.

### 11. THE MULTI-COLOUR INDICATOR

The indicator indicates the current status of the *BENOMIC S*, and is also a feedback to the user if the safety status of the *BENOMIC S* changes.

For this, see 5.3.1.

### 12. HYDRAULIC LIFTING OF THE TROLLEY

Pressing this button (once) will result in completely lifting the *BENOMIC S* or lowering it fully, after which it can be manually rotated and moved.

#### Attention!

- **Only lift the machine on a flat surface (on the concrete floor or on the main path), never lift it on the pipe-rail system or on a concrete floor with a slope!**
- **Fully lower the platform before lifting the *BENOMIC S*!**
- **Beware of toes and feet when lowering the *BENOMIC S*!**



### 13. BATTERY STATUS INDICATOR



You can read off the status of the batteries on the battery status indicator. If all LEDs light up, then the battery is fully charged, the battery charge is proportional to the number of LEDs that light up. The LEDs are coloured Orange and Red. When all the Orange LEDs are on, the batteries are charged 90 to 100%, for each Orange LED that goes out, approx. 10% battery power has been consumed. Charge the batteries if only 1-2 Orange LEDs light up on the battery status indicator. If this area is reached during work activities, then work can usually continue until the end of the day. When the last Orange LED starts flashing, the battery empty status is about to come into operation, complete the work in the harvesting path and follow the advice for battery charging given below. If an acoustic signal repeatedly gives two bleeps and the Red LED is illuminated, the *BENOMIC S* should be recharged immediately. The speed is automatically reduced and raising the work platform and lifting the machine up on the lift-wheels (used for moving the machine) is now no longer possible Switch the *BENOMIC S* off with the main switch and charge the battery without interruptions for at least 12 hours until the battery charger indicates full. (consult the battery charger's user manual!)

Avoid charging before the battery status indicator indicates 50% discharge (3–4 Orange LEDs). Always try to equalize the approx. 20% discharge status (1–2 Orange LEDs). This has the following advantages:

- Reduced number of charging cycles, improves the service life
- Less water use
- Less energy use

If the battery status indicator LEDs flash, then the *BENOMIC S* is being recharged without it being switched off using the main switch. Turn off the *BENOMIC S* and wait until the battery charger automatically stops charging, the batteries are then fully charged!

**Regardless of the level of usage, charge the batteries at least once a month using a suitable charger! Avoid deep discharge of the batteries, this causes severe damage and shortens the life!**

**See also the instructions contained in Appendix 3 Battery safety sheet!**

#### 14. CRUISE CONTROL IN THE HARVESTING PATH

The cruise control function can be activated in the harvest paths by pressing the push button (14) for 3 seconds, you will hear a beep and the signal lamp will flash light-blue. Then press and release the foot pedal, the *BENOMIC S* will move at the set speed. The signal lamp will illuminate, light-blue, continuously. Adjust the ground speed to your working speed with speed control knob (7).

The *BENOMIC S* will stop if the foot pedal is pressed briefly (signal light flashes light-blue), you do not need to hold the foot pedal down! Pressing the foot pedal a second time will restart driving with the cruise control function.

After reversing the direction of travel, you must reactivate the cruise control system by pressing and releasing the foot pedal.

On returning to the concrete path, the *BENOMIC S* automatically stops running when the pipe-rail sensor (in the middle of the trolley) no longer detects a pipe. The cruise control function will automatically switch off here!

The cruise control function can be deactivated by pressing the push button (14) again, the signal light then lights up green again.

#### 15. USB CONNECTION

The USB power connector serves to charge and/or power original USB accessories with a maximum consumption of 2.1 A per connection.

### 8.2 *Moving the BENOMIC S onto the main path*

There are two methods for moving the *BENOMIC S* along the main path. Always walk next to the trolley, never in front of it!

The first option is on its flange rollers. Select a direction of travel and speed (up to position 4). Press the foot pedal and the *BENOMIC S* will move in the selected direction.

The second option is to put the trolley on its lift-wheels. Press button (12); the *BENOMIC S* will now be supported its lift-wheels. The *BENOMIC S* is easy to turn and move sideways.

#### **Attention!**

- ***Never leave the BENOMIC S unattended on its lift-wheels.***
- ***Always walk next to/behind the trolley!***
- ***Take care with ramps and trenches, and reduce speed!***





### 8.2.1 *Crop work on a row of plants along a gable path*

It is possible to use the *BENOMIC S* to perform crop work on plants along a path with the working platform in an elevated position.

When driving on the concrete path with the working platform in a position higher than 80 cm, the speed is automatically limited to 30 m/min!

#### **Attention!**

- *The BENOMIC S is lacking continuity of pipe-rail and might gradually depart from its original track.*
- *Correct the position of the BENOMIC S in a timely manner, and do not hang over the safety railing!*
- *Take care with ramps and trenches, reduce the speed!*
- *The speed on the concrete path is limited!*
- *Always use the appropriate recommended personal protective equipment (PPE)! (see 5.2 Safety Systems)*



### 8.3 *Moving the BENOMIC S on the harvesting path*

The speed selected on the harvesting path is one that best suits the work. (See Appendix 3 *Efficient use of the pipe-rail trolley*)

The *BENOMIC S* will move in the desired direction as long as the foot pedal is operated. While driving, keep an eye on the position relative to the beginning and end of the harvesting path, moderate the speed and stop in time!

#### 8.3.1 *Driving into the harvesting path*

Position the *BENOMIC S* straight in front of a harvesting path and drive it fully onto the pipe-rails. When necessary, raise the work platform to working height using rotary knob (9) afterwards.

#### **Attention!**

**Always use the appropriate recommended personal protective equipment (PPE)! (see 5.2 Safety Systems)**



#### 8.3.2 *Driving out of the harvesting path*

On returning to the concrete path, the *BENOMIC S* automatically stops running when the pipe-rail sensor (in the middle of the trolley) no longer detects a pipe. Lower the work platform completely and activate the foot pedal, as described for foot pedal (5) in chapter 8.1.1.

The safest way to cross the main path is in the lowest position.

If crossing occurs with the working platform in a high position, the speed on the concrete path is automatically limited! Cross over or move the *BENOMIC S* to another harvesting path as described in chapter (8.2).

#### 8.4 **Automatically disconnect "sleep mode"**

The *BENOMIC S* is equipped with an automatic shut-off function to save energy when you forget to turn off the trolley at the main switch (1).

After one hour of no operation, the *BENOMIC S* will automatically enter "sleep mode", the signal lamp (11) and the battery condition meter (13) will no longer be illuminated.

Remove the *BENOMIC S* from this function by briefly pressing the HORN / RESET button (2 or 10) (see also 1. MAIN SWITCH / EMERGENCY STOP)

#### **Attention!**



- **The *BENOMIC S* is in "sleep mode", and not switched off!**
- **Never leave the *BENOMIC S* unattended when the key is still in the main switch!**

#### 8.5 **Out of service**

If the *BENOMIC S* is out of service, make sure the platform is in the lowest position and the lift-wheels are retracted so that the trolley stands on its flange rollers. Always switch off the machine, using main switch and remove the key. Store it **with charged batteries** in a moisture-free and frost-free room. It is recommended to connect the batteries on the *BENOMIC S* to a trickle charger. Otherwise, the batteries should always be charged at least monthly (even if the *BENOMIC S* remains stationary for a long time). Provide a level surface and protect the trolley from direct sunlight. If the *BENOMIC S* is put back into operation after a longer period in storage, it must first be inspected as described in section 7.1 (Inspection before starting operations).

#### 8.6 **Cleaning**

Regularly remove any remains of plants, leaves, etc. and brush off any sand and dust. Clean the pipe-rail trolley with a dry/damp cloth and soft brush. If it is dry, you may clean the *BENOMIC S*, with compressed air. Never pour water over the *BENOMIC S* and/or clean the machine using a steam or high-pressure water cleaner, as this can cause serious damage to the electrical circuits

Every week, remove sand and dirt from the frame at the level of the scissor-slide blocks. See also Appendix 4. Cleaning the powder coat finish

## 8.7 **Problems, causes and solutions**

The *BENOMIC S* is equipped with various safety systems that can temporarily block the intended functions, for example through incorrect operation.

In order to alert the user to a changing status or incorrect operation of the *BENOMIC S* during use, a multi-colour indicator (11) and horn is used. For the situations below, first always refer to chapters 5.3.1 and 5.3.2!

### **Problem A : The *BENOMIC S* does not run.**

- Cause** : **Key switch is disabled**  
**Solution** : *Enable key switch (vertical)*
- Emergency stop locked**  
*Release emergency stop (turn / pull out)*
- Speed potentiometer at 0**  
*Set a speed*
- Motor controller fault**  
*Switch off and on again with the main switch*  
*Consult your dealer*
- Battery terminals make poor contact**  
*Clean the battery terminals, remount the clamps*
- Defective foot pedal**  
*Replace foot pedal, consult your dealer*
- Lifter not withdrawn far enough or sensor defective**  
*Withdraw lifter (system) fully (12) or check sensor*
- 25A circuit breaker in 0-position**  
*Consult your dealer*
- 6.3 A control circuit fuse defective.**  
*Consult your dealer*

### **Problem B : Speed can be poorly adjusted.**

- Cause B** : **Speed control button is defective.**  
**Solution** : *Consult your dealer*
- Pipe-rail sensor is defective (only runs slowly)**  
*Consult your dealer*
- Drive motor control is defective**  
*Consult your dealer*

---

**Problem C : The work platform will not raise/lower.**

- Cause C :** **Lift-system sensor not activated/defective**  
**Solution :** *Withdraw lifter system fully or check sensor*  
**Batteries empty** (Red LEDs on battery status indicator and 2x cyclic bleeps)  
*Charge batteries*  
**Battery terminals make poor contact**  
*Clean the battery terminals, remount the terminals*  
**Key switch is off**  
*Enable key switch (set vertical)*  
**Emergency stop pressed**  
*Release emergency stop (turn / pull out)*  
**Overloaded**  
*Reduce load. (see 10. Specifications)*  
**insufficient hydraulic fluid**  
*Replenish hydraulic fluid (scissors up, supplier information)*  
**Switch/button faulty**  
*Try the scissor-control service button next to the main switch*  
**80 A fuse defective.**  
*Consult your dealer*  
**6.3 A control circuit fuse defective.**  
*Consult your dealer*

---

**Problem D : The lifter system won't go out/in.**

- Cause D :** **The work platform is too high**  
**Solution :** *Lower the work platform to the lowest position*  
**The BENOMIC S is on the pipes**  
*Drive the trolley off of the pipes*  
**Batteries empty** (Red LEDs on battery status indicator and 2x cyclic bleeps)  
*Charge batteries*  
**Battery terminals have poor contact**  
*Clean the battery terminals, remount the terminals*  
**Key switch is off**  
*Enable key switch (set vertical)*  
**Emergency stop pressed**  
*Release emergency stop (turn / pull out)*  
**Insufficient hydraulic fluid**  
*Replenish hydraulic fluid (scissors up, supplier information)*  
**Switch/button faulty**  
*Try the scissors control service button next to the main switch*  
**80 A fuse defective.**  
*Consult your dealer*  
**6.3 A control circuit fuse defective.**  
*Consult your dealer*

---

**Problem E : The BENOMIC S has overturned.**

**Cause E** : - **Carelessness with the forklift truck**  
- **Unstable pipe-rail system**  
- **Excessive applied force**  
- **Overloaded**  
- **Tilt detector ignored**  
- **Have run into a path next to the pipes**  
- **Lifting on uneven surface**

**Solution** : 1. *Switch the trolley off*  
2. *Set the trolley upright*  
3. *Remove covers*  
4. *Disconnect the batteries*  
5. *Clean the trolley*  
6. *Observe the damage*  
7. *Find the cause and provide a sustainable solution*  
8. *Check according to chapter 7*

**!!!BEWARE of liquids, battery acid is very corrosive!!!**

## **8.8 Disassembly**

If your *BENOMIC S* has become so worn and defective that it must be dismantled, you must take it to your supplier or another company that specialises in dismantling vehicles. Never take your *BENOMIC S* to a scrap metal merchant or dump. The *BENOMIC S* must be dismantled and chemical parts (hydraulic fluid and batteries) must be disposed of correctly.



Deposit defective batteries at your municipal dump or your supplier.  
Dispose of oil/fluid as chemical waste.



## 9. Maintenance and repairs

The *BENOMIC S* is a very high-quality product. The following maintenance instructions must be strictly followed to safeguard its quality. Repair and maintenance work must be recorded in the maintenance logbook (see Appendix 1). The employer is also responsible for periodically checking tools and equipment according to the current Working Equipment Guidelines.

Switch off the *BENOMIC S* by means of the main switch before starting maintenance.

Maintenance - Checks	Tools	Daily	Weekly	Monthly	Yearly
Sufficiently charged battery (see 8.1.2 (13))	Battery status indicator	X			
Damage to control components	Visually	X			
Damage to/visibility of pictograms and stickers	Visually	X			
Cleaning the foot pedals + platform	Brush / Damp cloth		X		
Cleaning the control panel	Brush / Damp cloth		X		
Clean the frame and scissor-slide blocks	Brush / Damp cloth		X		
Check for leakage, and damaged cables and hoses	Visually		X		
Check for ingrained dirt or string wrapped around wheels and chain	Visually		X		
General mechanical damage	Visually		X		
Lifting and lowering movement – check for jerkiness (low hydraulic fluid level)	Hydraulic fluid ISO Viscosity Grade 46		X		
Charge batteries when necessary, and at least once per month (see 8.1.2 (13))	Battery charger			X	
Check battery fluid levels (plates should be 1 cm below the fluid level, see Appendix 3)	Distilled water, gloves and glasses			X	
Check that the tilt signal is operating correctly	Test > 2 degrees			X	
Check for leaks on hydraulic components (pump/valves) under the cover	Tool to remove bolt from the cover			X	
Check pipe-rail wheel wear (see 9.5)	Visually			X	
Grease the hoist wheels, drive chain and ball bearings	Ball-bearing grease, chain lubricant or another universal lubricant			X	
Check chain tension (see 9.4)	Open-ended spanner			X	
Cap mountings on the scissor-shafts	Visually			X	
Grease the hinged parts of scissor-unit (see 9.2)	Grease gun and grease				X
Grease the hinged parts on the lift-system	Spray grease/lubricating grease				X
Check welds on the scissor-unit for cracks (hairline) and rust	Visually				X

If the above checks show that there is a fault on the *BENOMIC S*, contact your *BENOMIC S* dealer immediately. Operating the trolley despite there being defects found can be very dangerous and is therefore strictly forbidden!

### 9.1 Specialist maintenance

Maintenance and repairs to the items listed below may only be carried out by approved Berg Hortimotive dealers:

- Work on electrical components/wiring, (excluding foot pedal exchange)
- All work on the hydraulic system.
- All work concerning the drive motor and the reducer unit (excluding cleaning, readjustment or replacement of the chain and chain-sprockets).

## 9.2 Maintenance on, in or under the scissor-unit

For maintenance work on, below or between the scissors construction, the scissor-locking device should be unfolded. Remove the cover plate (Figure A). Fold out the catch with the scissors up. Lower the scissors (B) until it is against the safety catch. Now switch off the *BENOMIC S* with the main switch.

After maintenance, turn on the *BENOMIC S* with the main switch.

By subsequently pressing the release button (2) for 5 seconds (audible bleep) and keeping it pressed, the service key (3) will be released for use. Send the work platform slightly up, after which the locking catch can be folded. Then operate the platform completely down.

Now use the horn / reset button (10) to activate the *BENOMIC S*, 'reset' after using the main switch (1) or the emergency stop (8). After this operation, the indicator (11) will light up Green continuously when the *BENOMIC S* is in a safe status, it is then ready for use.

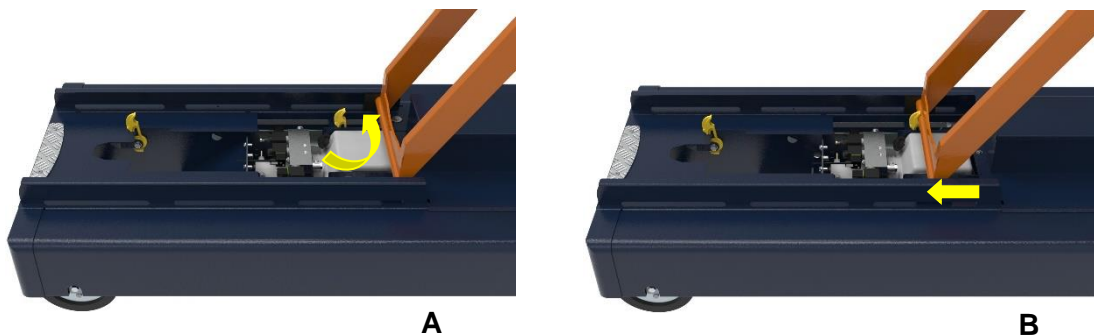

Figure 9.1 A–B; Unfolding the scissor-lock

The scissor shafts run on bearing bushes. The inner-parts of the scissors are connected to the outer ones with a shaft. To prevent rust on the shafts, lubricate them with a universal lubricant, using a grease gun at least once annually. Raise the scissors and block the unit using the scissor-lock (see figure 9.1). Put the grease gun on the nipples (see figure 9.2) and pump in grease until it comes out at the ends of the bearing bushes.

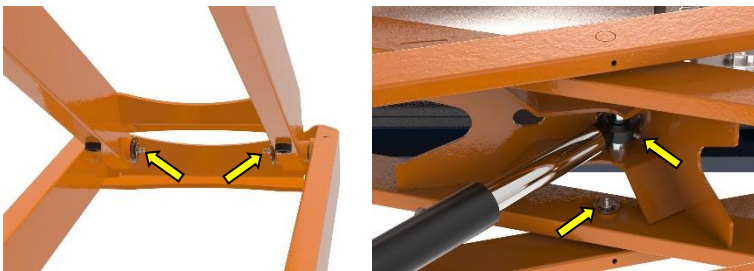

Figure 9.2; Position of the scissor shafts and cylinder rod head grease nipples

## 9.3 pipe-rail system maintenance

The pipe-rail system on which the *BENOMIC S* runs should be checked on a regular basis. The *BENOMIC S* has been designed to run on a stable pipe-rail system. This means that each path between the crops has a track comprising two pipes of the same diameter with a fixed width between them (centre-to-centre, c.t.c. size). The pipes are often used as heating pipes and are supported along fixed distances.

Stability tests have shown that with unfavourable combinations of pipe type and support spacing on the pipe-rail system, constraints must be applied for the maximum permissible load. See 10.1 Explanation of the technical specifications.

Moreover, the pipes on the concrete path should be secured and must not be loose. Regardless of the pipe-rail system, our requirement is that a maximum support distance of 1 metre is applied in the last 10 meters! At the pipe ends (in front of the façade) there should be an end-stop welded on that is at least 5 cm in height - at the end of each season check whether the stops are not flat, folded, crooked or broken. The ground under the pipe-rail system should be dry, flat and hard. Soft or damp spots should be repaired and surface indentations permanently repaired.

Additional information can be found in chapter 7.3 Minimum requirements for the pipe-rail system.

## 9.4 Chain tightening

The chain tension should be approximately 1 cm. If it is not, proceed as follows:



Figure 9.5: Chain tension

1. Turn off the *BENOMIC S* with the main switch and remove the key from the ignition to prevent the *BENOMIC S* from being enabled.
2. Unscrew the 2 chain-case mounting bolts (a) approx. one cm
3. Slide the chain-case in the direction of the arrow (1) toward the larger holes
4. The chain-case can then be removed in the direction of the arrow (2)
5. Loosen the third motor mounting bolt (B) a little
6. Tighten the chain by tightening the adjustable lock nut (C) \*
7. Tighten the motor mounting bolts (B) again firmly
8. Install the chain-case and tighten the mounting bolts (A) securely.

\* Allow chain slack of about 1 cm.



## 9.5 Check pipe-rail wheel wear

Every running surface of any material is subject to wear.

The material of the flange rollers has the following favourable characteristics:

- Flange rollers are silent
- Rolling resistance is low
- Lower load for the heating pipes
- Acceptable durability

With this information we want to indicate when it is time to proceed with replacing the flange rollers.



Wear is approx. 1 mm; the rollers have been in use for some time.

Normal maintenance, inspection for run-in string.



Wear is 2-3 mm; the rollers are still fine.

Normal maintenance, inspection for run-in string.  
Roller replacement not yet necessary.



Wear is 5 mm or more. The roller has flat sides and has been blocked.

Replacement is now necessary!  
Consult your dealer.

## 10. Technical Specifications

Type:	xxxx.xx.xxxx
Dimensions [mm]:	2 scissors S350
C to C dimension*	425 - xxx
Length	1910
Width	c to c + 186
Wheelbase [mm]	1630
Undercarriage step-up height from a concrete path	257
Step-up height to platform in lowest position of chassis step	273
Control panel height from platform	1007
Length of work platform	1900
Width of work platform	460
Max. work platform height*	3500
Max. Load capacity [kg]	250
Max. lateral pressure [N]	110
Weight [kg] (c-to-c 420)	415
Motor power [kW]	0.25
Motor power [kW]	1.2
Hydraulic system pressure [bar]	200
Hydraulic fluid, viscosity 46 [L]	2.9
Max. speed on rails [m/min]	60
Max. speed on concrete [m/min]	83
Max. lifting speed [m/sec.] #	0.16
Max. lowering speed [m/sec.] # (# at 80 kg load)	0.23
Voltage [Volt DC]	24
Battery capacity [Ah] (5h/20h)	120/159
USB connection 2x [Volt/Amps]	5V/ 2.1A
Vibration level [m/sec <sup>2</sup> ]	<0.5
Noise level [dB]	<70

### 10.1 \* Explanation of the technical specifications

Stability tests have shown that the following restrictions must be applied with unfavourable combinations of: pipe-rail type and support spacing on the pipe-rail system.

- A: Pipe diameter
- B: Pipe rail system center to center measurement (track width)
- C: Bracket distance
- H: Platform height

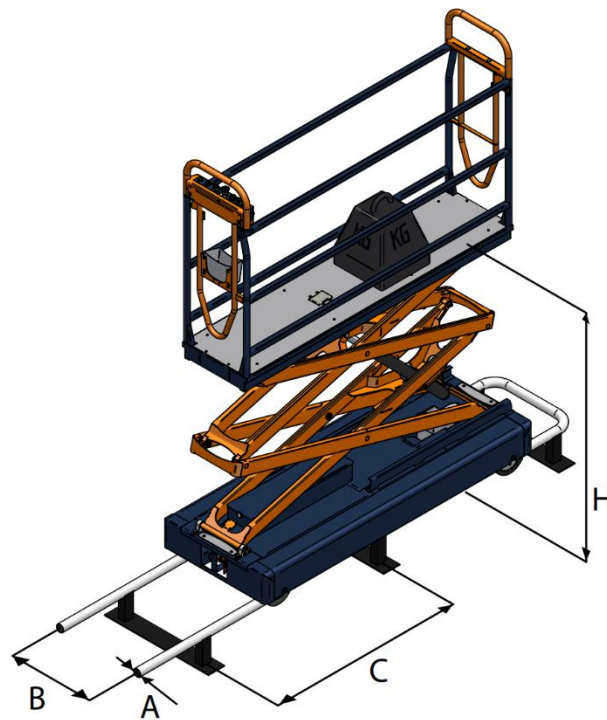

A = 45 mm			
B =	≤ 52 cm	> 52 cm	
C =	Max. 1.25 metres		
H =	2.5	X	150 kg
	3.0	X	
	3.5	X	
<b>Not recommended by Berg Hortimotive</b>			

A = 45 mm			
B =	≤ 52 cm	> 52 cm	
C =	Max. 1 metres		
H =	2.5	250 kg	250 kg
	3.0	120 kg	
	3.5	X	

A = 51 mm			
B =	<52 cm	≥ 52 cm	
C =	Max. 1.25 metres		
H =	2.5	250 kg	250 kg
	3.0	120 kg	
	3.5	X	

Regardless of the pipe-rail system above, our requirement is that a maximum support spacing (C) of 1 metre is applied in the last 10 meters!

## 11. EC DECLARATION OF CONFORMITY

(according to Annex IIA of the Machinery Directive)

**Berg Hortimotive**  
**Burg. Crezeelaan 42a**  
**2678 KZ De Lier - Holland**  
**T: +31 (0)174 – 517700**  
**www.berghortimotive.com**

While taking full responsibility, hereby declares that the product:

- ***Pipe-rail trolley type BENOMIC S with double hydraulic scissors and hydraulic lift-wheels to 3.5 metres height***

**Article number:** .....

**Serial number:** .....

- Meets the requirements of the Machinery Directive 2006/42/EC

**Satisfies the following other EC directives:**

- Electromagnetic Compatibility Directive (EMC) 2014/30/EU (as recently amended)

TÜV NEDERLAND QA B.V.  
Ekkersrijt 4401  
5692 DL Son en Breugel  
Country: Netherlands

Phone: +31:499:339500  
Fax: +31:499:339509

Email: [info@tuv.nl](mailto:info@tuv.nl)  
Website: [www.tuv.nl](http://www.tuv.nl)

Notified Body number: 1231

EC type examination TÜV Netherlands no. 2400-B-528

*De Lier, The Netherlands, date .....-.....-.....*

*Signature of managing board or authorised signatory. ....*

---

## Appendix 1: Maintenance logbook

Describe repairs and/or maintenance operations on the form below.

Date	Description of repair/maintenance Type no.:.....Series no.:.....	Name of company/technician

## Appendix 2: TECHNICAL DRAWINGS

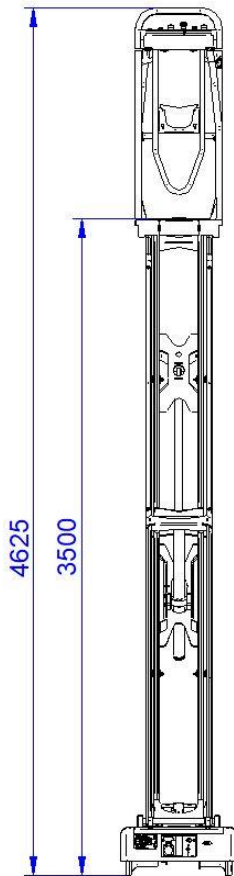

Fig. 2.2; Maximum height dimensions in mm, 2 scissors

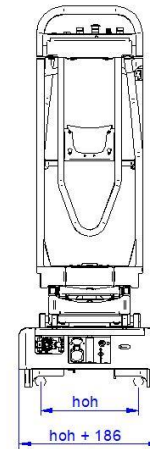

Fig. 2.1; Width dimensions in mm, 2 scissors  
NL: h.o.h. EN: c.t.c.

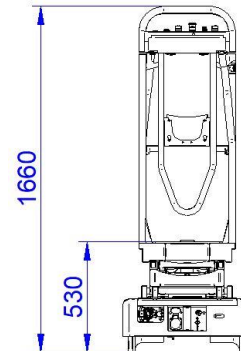

Fig. 2.3; Minimum height dimensions in mm, 2 scissors

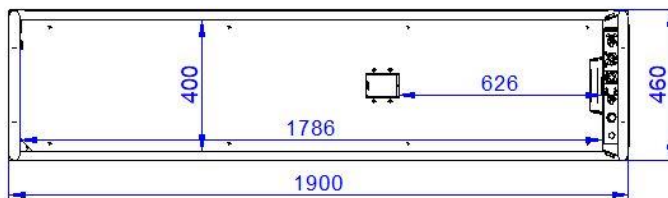

Fig. 2.4; Platform dimensions in mm, 2 scissors

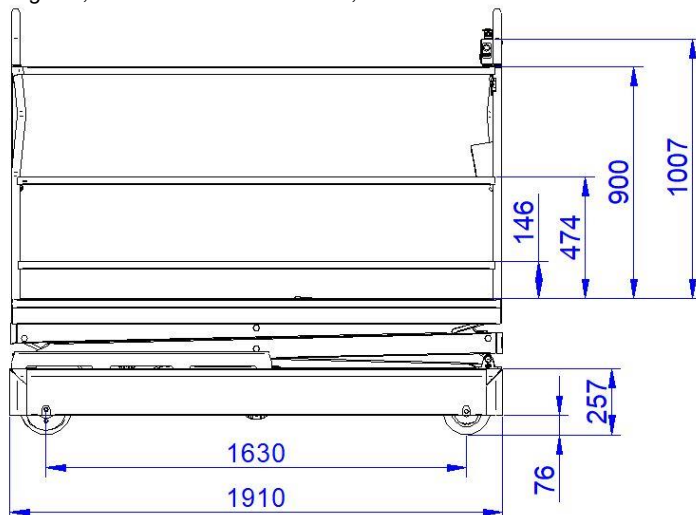

Fig. 2.5; Length dimensions in mm, 2 scissors

## Appendix 3: Battery safety sheet

### Battery advice

The following chapter gives advice on efficient use, safety and maintenance.

### Efficient use of the pipe-rail trolley and batteries

The following recommendations are aimed at facilitating the efficient use of the pipe-rail trolley and to improve the life-cycle of the batteries.

#### Basic principles:

- The battery goes flat sooner when running at higher speeds.
- High levels of starting and stopping increase electrical energy consumption.
- Through using the pipe-rail trolley, the remaining capacity and battery voltage gradually reduces, while simultaneously the current consumption increases. This results in increasing heat generation from the motor and speed regulator as the batteries gradually lose their charge.
- Worn rollers, or rollers with wound string, and rusty chains (poor maintenance) all result in higher energy consumption. (for maintenance instructions, visit our website: <http://www.berghortimotive.com/service/bsa-film>)
- Allowing batteries to go (completely) flat also reduces the life-span.
- Charging when required and good maintenance help to increase the life-cycle of the batteries.
- Charging when required also lowers the generation of heat in the motor and speed regulator, as well as the battery charger.

#### Efficient usage:

- Adjust the driving speed as much as possible to the working speed (potentiometer)
- By following the above recommendations, the productivity of the workers will increase too.

#### Safe use of the batteries

Below are some recommendations for use and maintenance.

#### WARNING!



- **When charging the batteries, an explosive gas is formed: fire, naked flame and smoking is prohibited!**
- **Only charge in properly ventilated spaces using a suitable charger!**
- **The fluid level must be checked every month! The battery fluid must be at least 1 cm higher than the plates.**
- **Only replenish using distilled (demineralised) water (use gloves)!**
- **Always replenish the batteries AFTER charging and never fill above the level mark at the battery cell filler hole (also see the traction battery instruction sheet).**

Discharging for more than 20% adversely affects the lifespan of the batteries and charger. Charge the batteries when the battery status meter shows 1–2 illuminated LEDs, this will benefit the lifespan of the batteries, the motor and the drive control! Always charge an empty battery immediately, this will significantly benefit the lifespan. So, preferably check the acid concentration every week, but check at least every month with a hydrometer (fig. A+B and table below).

With fully charged batteries, the specific mass (SM) should be 1280 g/l:

100%	Density 1280 g/l	=	12.7 volt
80%	1240		12.5
60%	1210		12.3
40%	1170		12.1
20%	1140		11.9

Switch off the *pipe-rail trolley*, at the main switch, before charging. When about to charge, always first connect the batteries to the charger, and afterwards switch on the charger. When charging is complete, first switch off the charger, then disconnect the battery.

Charging the batteries 'too much' can cause damage to the batteries because the battery fluid will boil for a longer period of time.

The use of a modern battery charger with automatic cut-off, available from Berg Hortimotive, is recommended. **Only use a charger that is suitable for the batteries used! (see charger instructions)**

Never interrupt charging, completely finish charging, see indication on charger.

#### **WARNING! Danger of injury with the batteries:**

Avoid the battery fluid (electrolyte) coming into contact with skin, wear safety goggles and gloves as battery acid is highly corrosive. Wash with soap and water if contact is made. If it comes into contact with the eyes, immediately rinse in running water for a period of at least five minutes and call for medical assistance. Always ensure there is sufficient soap and water in the vicinity and that assistance is within calling distance when people have to work near batteries. Avoid short circuits (sparks), and ensure that there is no electrical connection between the battery poles. The battery cover must be free of damage. Bare patches or dents can cause short circuits!

Explosive gas is released when the batteries are being charged. Keep sparks, naked flames or cigarettes away from batteries.

Do not repair, clean or carry out other activities on the pipe-rail trolley while charging.

Before uninstalling the batteries, always switch off all current consumption items, to avoid sparks.

Ensure that the place where batteries are charged and/or stored is well ventilated. Ensure that no metal objects can fall on the batteries as this could cause short circuits or sparks which in their turn could lead to an explosion.

Remove all personal objects including rings, bracelets, necklaces and wristwatches when working in the vicinity of batteries, because, for example, a short circuit could melt a ring resulting in serious burns.

When dismantling the battery, first disconnect the ground cable (-). When mounting, connect the ground cable (black) last of all.

#### **WARNING!**

**Always connect the plus (+ = red) to the plus terminal and minus (- = blue) to the negative terminal.**

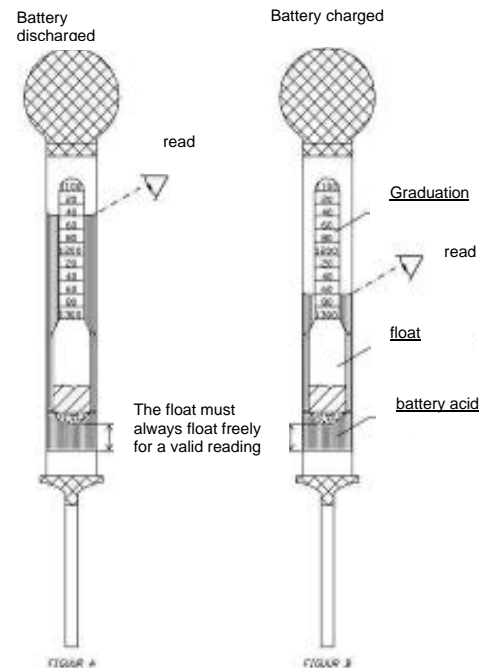



**Remark**

Check how many battery chargers you can connect to one circuit. You can check this by multiplying the number of amperes of the fuse with the voltage. E.g.:  $16\text{ A} \cdot 230\text{ V} = 3680\text{ W}$

Subsequently check the battery charger power rating. Divide the total power by the battery charger's power. E.g.:  $3680/500 = 7.36$ . In this case, seven battery chargers can be connected.

Also check that the voltage at the charging location corresponds with the voltage indicated on the battery charger. There may be voltage loss with long cables. If this is the case, you should consult your installer.

Check that it is the correct charger for your machine. The battery specifications that can be used with the charger are indicated on the charger or in the user manual!

	TREM-CARD	<b>UN 2794</b>
---	-----------	----------------

**Substance Batteries wet, filled with acid, electrical storage**

**UN Number 27**

**HIN 80**

**ADR Label 8**

**ADR Class 8**

**Packing group -**

**Emergency Response Information****CORROSIVE SUBSTANCE****1. Characteristics**

- Corrosive, causing damage to skin, eyes and air passages
- Not flammable

**2. Hazards**

- Heating of container(s) will cause pressure rise with risk of bursting and subsequent explosion (BLEVE).
- Gives off corrosive and irritant fumes, also when burning
- May attack metals and produce hydrogen gas which may form explosive mixture with air
- The vapour may be invisible and is heavier than air. It spreads along the ground and may enter sewers and basements

**3. Personal protection**

- Chemical protection suit.
- Respiratory mask equipped with ABEKP1 filter



## **4. Intervention actions**

### **4.1 General**

- Keep upwind. Put on protective equipment before entering danger area.

### **4.2 Spillage**

- Stop leaks if possible.
- Dilute spillage with water spray as far as necessary to reduce hazard. Contain run off by any means available.
- If substance has entered a water course or sewer, inform the responsible authority.
- Ventilate sewers and basements where there is no risk to personnel or public

### **4.3 Fire (involving the substance)**

- Keep container(s) cool with water
- Extinguish with water fog (spray)
- Do not use water jet to extinguish
- Use water spray to knock down fire fumes if possible
- Avoid unnecessary run-off of extinguishing media which may cause pollution.

## **5. First aid**

- If substance has got into eyes, wash out with water for at least 15 minutes and seek immediate medical attention.
- Remove contaminated clothing immediately and drench affected skin with plenty of water.
- Persons who have been in contact with the substance or have inhaled fumes should get immediate medical attention. Pass on all available product information.
- Mouth to mouth resuscitation should be avoided. Use alternative methods, preferably with oxygen or compressed air driven apparatus

## **6. Essential precautions for product recovery**

- Use acid resistant equipment
- Recover spilled product in vented container fitted with absorption filter

## **7. Precautions after intervention**

### **7.1 Undressing**

- Drench contaminated suit and breathing apparatus with water before removing face mask and suit.
- Use chemical protection suit and self-contained breathing apparatus while undressing contaminated co-workers or handling contaminated equipment.

### **7.2 Equipment clean up**

- Drench with water before transporting from incident.



# INSTRUCTIONS TRACTION BLOCKS



## Daily maintenance EW159T:

- Only discharge the battery to 80% maximum (Electrolyte level 1130 SG)
- Connect the battery to the charger, switch on charger and charging should start automatically
- Do not disconnect the battery until charge cycle has finished
- When charge cycle has completed make sure charger is switched off before disconnecting the DC plug

## Weekly maintenance EW159T:

- Check the level of the Electrolyte on the battery  
Only top up battery with demineralised water
- Only top up after charge cycle has completed
- The battery should only need topping up every 2 weeks
- If required more frequently please contact the manufacturer
- Check for signs of corrosion on cables or bolts clean as required
- The battery tops should be kept clean and dry  
No smoking or naked flames to be in the area of charging

Only top up the battery after the charging cycle has been completed to avoid electrolyte spilling from the battery!  
No smoking or naked flames to be in the area of charging.

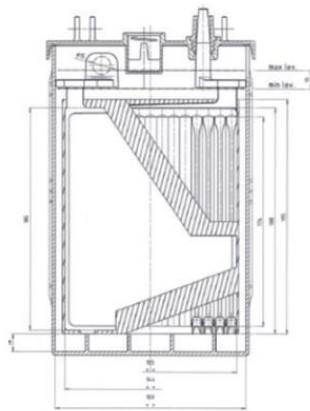

Green is maximum level

Red is minimum level



Always follow the manufacturer's instructions



No smoking or naked flames



Electrical Hazard



Danger risk of explosion



Always wear the correct PPE



Avoid contact of skin and eyes



Room must be well ventilated



Pb  
All disused batteries must be recycled

## Appendix 4: Cleaning the powder coat finish

### The importance of cleaning and maintenance:

- The product's appearance and finish are maintained for longer.
- Its service life is extended.
- Helps to resist corrosion.
- It has a positive effect on preventing spread of plant diseases.
- Encourages employees to handle machines carefully.

By periodically removing the contamination, the chemicals present in and on the machine prevents them from working into the powder coat finish. Protective layers are sensitive to acids, salts and other aggressive substances and age faster if contaminated. In addition, thick layers of dirt can absorb and hold more moisture, which can increase the aggressive impact on the protective layer.

### The cleaning frequency depends on:

- The level of contamination is cultivation related.
- Product type, used between crop or, for example, only on concrete paths.
- Exposure to chemical liquids (spraying equipment).
- Exposure to chemical vapours (space treatments in greenhouses).
- Exposure to sun and UV radiation.
- Humidity and condensation.

The above items give a load factor that is dependent on usage. If applicable, the following cleaning schedule should be followed.

### When to clean:

- |  |                               |
|--|-------------------------------|
| • Plant and product residues.                            | daily                         |
| • Soil and sand.   | Twice per week                |
| • Glass, rope, plastic, elastic, clips, wire hooks, etc. | Twice per week                |
| • Chemical exposure.                                     | Clean immediately after use   |
| • Dull and contaminated surface finish.                  | Periodically, after detection |

### How to clean:

- Remove contamination on the paint surface or with tool (soft brush or cloth) or compressed air (<6 bar!).
- After chemical exposure, remove contamination with coarse sponge or soft cloth soaked in tap water.
- Clean dull and contaminated paint with neutral detergent with pH between 5 and 8 (see cleaning agent label) and sponge or soft cloth.
- **Tip** – If a cleaning agent is used for the first time, we recommend testing it on a sample piece before cleaning the entire machine.

### What you should definitely not do:



- Never clean powder coatings with abrasive or polishing cleaning agents.
- Do not use a tool with abrasive surface (steel wool, scouring pads, etc.).
- Hard pushing, brushing, scrubbing etc. is not permitted.
- Do not use organic solvents to clean or preserve the powder coat paint.
- Pouring water, using a water hose or high-pressure washer can cause damage.

### After cleaning:

- Make sure all the cleaned surfaces are able to dry properly, temporarily loosen overlapping shield covers.
- Lubricate pivot points that have come into contact with cleaning agents, doing so according to the recommendations in the maintenance schedule of the User Manual.
- Repair any damage to the powder coat with a suitable paint.

### Attention!

The **recommendations** above are the responsibilities of the party responsible for carrying out the cleaning. If you have any questions regarding the cleaning product to be used, please consult the manufacturer.

# Appendix 5: Quick Start Guide

## Quick Start Guide



### Benomic S350 Control panel



1. Off / On switch



2. Button to lift wheels

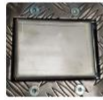

3. Gas pedal



4. Cruise control switch



5. Direction button

6. Speed button

7. Emergency button

8. Platform button

9. Claxon / reset

10. Status light

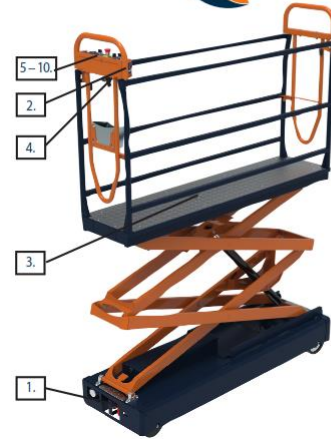

Turn on	Lift wheels	Set direction	Drive speed	Drive	Lift platform	Cruise control	
Turn switch [1] vertical and push the claxon / reset button [9]	Push button [2]	Turn button [5] in the right direction	Set button [6]	Push the gas pedal [3] 1 time to drive	Turn button [7] to lift platform	Push button [4] > 3 seconds	Drive/Stop

Tilt indication and follow up		
Safe	Attention	Critical

Safety			
Emergency stop	Batteries empty	Weight overload	Wrong operation

Daily maintenance (end of the day)		
Battery check	Batteries empty	Cleaning