



Technical Handbook

BENOMIC STAR 260



Berg Hortimotive

**Burg. Crezeelaan 42a
2678 KZ De Lier
The Netherlands**

Tel: +31 (0) 174- 517 700

**Email: info@berghortimotive.com
Internet: www.berghortimotive.com**

Machine type plate

The *BENOMIC STAR 260* is fitted with a machine type plate which contains the following information: address details for Berg Hortimotive, CE mark, serial and type reference, serial number, year of construction.

If you would like to contact Berg Hortimotive, or one of their dealers with respect to this *BENOMIC STAR 260*, please ensure that this information is always readily available.

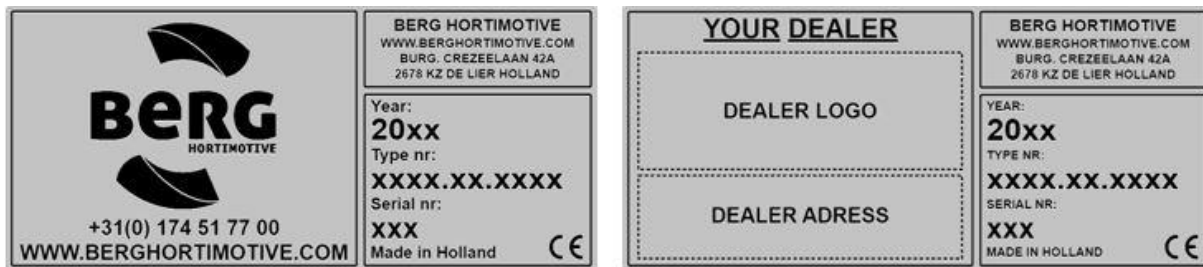

Version 4, September 2020

The machine is manufactured by:



Berg Hortimotive

Burg. Crezeelaan 42a
2678 KZ De Lier
The Netherlands

Tel: +31 (0) 174- 517 700

Email: info@berghortimotive.com
Internet: www.berghortimotive.com



1. Declaration

1.1 Copyright

Berg Hortimotive
De Lier, 2020

No part of this publication may be reproduced and/or published by way of print, photocopy, film or by any other means without the prior written consent of Berg Hortimotive, registered at De Lier, the Netherlands.

Exceptions to this include parts of the documentation which are intended for reproduction, such as abridged instructions and specifications on the machine itself.

1.2 Liability

Berg Hortimotive does not accept liability for dangerous situations, accidents and damage that occur as a result of ignoring warnings or instructions, such as those shown on the *BENOMIC STAR 260*, or contained in this documentation - for example:

- inexperienced or incorrect usage or maintenance
- being used for applications other than those for which it was designed, or in circumstances other than those given in this documentation
- the use of components or spare parts which are not prescribed
- repairs carried without the consent of Berg Hortimotive and/or a certified dealer
- changes to the *BENOMIC STAR 260* include the following:
 - alterations to the controls
 - welding, mechanical works, etc
 - extensions to the *BENOMIC STAR 260* or its controls

Berg Hortimotive does not accept liability when:

- customers do not meet their obligations with respect to Berg Hortimotive (financial or otherwise)
- consequential damage is caused by defects on the *BENOMIC STAR 260* - e.g. interruption of business, delays, etc.

1.3 **Guarantee**

For a period of 6 months after delivery, Berg Hortimotive gives the client a warranty on material and manufacturing defects that occur during normal use. This warranty does not apply if the defects are caused by improper use or causes other than by material and manufacture, if Berg Hortimotive - following consultation with the client - delivers used material or used goods or if the cause of the defects cannot be demonstrated clearly. The warranty provisions are set out in the METAALUNIE CONDITIONS as they read according to the most recent relevant text. The terms and conditions of delivery are available on request.

The warranty given by Berg Hortimotive for all goods and materials not manufactured by Berg Hortimotive will never be more than that given by its supplier. The warranty is ex works. Faulty machines and/or parts must be sent postage paid.

When it is not possible to send out machines or systems, any travel and subsistence expenses will be payable by the client.

Sold and delivered goods with manufacturer's, importer's or wholesaler's warranties are subject only to the warranty provisions set by the suppliers.

Hydraulic pumps are subject only to the manufacturer's warranty, provided the pump comes with an undamaged safety seal from the supplier.

Berg Hortimotive accepts responsibility for the availability of replacement parts, provided they are available from its suppliers at reasonable conditions.

2. **Foreword**

This handbook describes the *BENOMIC STAR 260*.

This handbook provides you with information including the safety aspects, a description of the *BENOMIC STAR 260* together with the working principles, as well as the operating instructions and maintenance of the machine.

Potentially dangerous situations are indicated together with recommendations for avoiding them.

It is important that this handbook is carefully read in order to learn how the *BENOMIC STAR 260* should be operated and maintained. By reading this handbook and then using the *BENOMIC STAR 260*, you, or anyone else, will be assisted in using the *BENOMIC STAR 260* in the correct manner thereby helping to avoid personal injury as well as damage to the machine.

Berg Hortimotive produces safe machines. The machines are designed to meet the latest standards and are manufactured in accordance with the latest CE approval markings. The user remains responsible for the proper operation and for carrying out maintenance on the machine.

Table of contents

1. DECLARATION.....	3
1.1 COPYRIGHT.....	3
1.2 LIABILITY.....	3
1.3 GUARANTEE.....	4
2. FOREWORD	4
3. INTRODUCTION	6
3.1 GENERAL.....	6
3.2 SUPPLIERS INFORMATION.....	6
4. SAFETY.....	7
4.1 EXPLANATION OF THE SAFETY TERMINOLOGY	7
4.2 SAFETY INSTRUCTIONS	7
4.3 SAFETY PICTOGRAMS	10
4.4 RESIDUAL RISKS	10
5. INTENDED APPLICATION	11
5.1 AREA OF APPLICATION	11
5.2 MAIN COMPONENTS OF THE BENOMIC STAR 260	11
6. TRANSPORTATION	13
6.1 EXTERNAL TRANSPORT	13
6.2 INTERNAL TRANSPORT	13
7. PUTTING INTO OPERATION	14
7.1 INSPECTION BEFORE STARTING OPERATIONS.....	14
7.2 HORTICULTURE SECTOR GUIDELINES FOR PIPE RAIL SYSTEMS	14
7.3 MINIMUM REQUIREMENTS FOR THE PIPE RAIL SYSTEM	15
7.4 TILT ALARM	16
8. USE	17
8.1 CONTROLS.....	18
8.1.1 <i>Controls on the chassis</i>	18
8.1.2 <i>Controls on the platform</i>	19
8.2 EMERGENCY LOWERING VALVE.....	21
8.3 MOVING THE BENOMIC STAR 260 ON THE MAIN PATH	21
8.4 OUT OF USE	21
8.5 CLEANING	22
8.6 PROBLEMS, CAUSES & SOLUTIONS.....	22
8.7 DISMANTLING	23
9. REPAIRS & MAINTENANCE.....	24
9.1 SPECIALIST MAINTENANCE	24
9.2 MAINTENANCE AND INSPECTION BY THE OPERATOR	25
9.3 BERG SERVICE ALERT.....	25
9.4 MAINTENANCE IN AND AROUND THE SCISSOR MECHANISM.....	26
9.5 INSPECTING THE CARBON BRUSHES.....	26
9.6 CHAIN TENSIONING.....	27
9.7 ADJUSTING FALL VELOCITY OF SCISSORS PLATFORM	28
9.8 CHARGING THE BATTERIES.....	28
9.9 PIPE RAIL SYSTEM MAINTENANCE	29
10. TECHNICAL SPECIFICATIONS.....	30
11. EG DECLARATION OF CONFORMITY	31
APPENDIX 1: MAINTENANCE LOGBOOK.....	32
APPENDIX 2: TECHNICAL DRAWINGS	33
APPENDIX 3: BATTERY SAFETY SHEET	34
APPENDIX 4: CLEANING THE POWDER COATING	39

3. Introduction

3.1 General

You have made a good choice by purchasing the Berg Hortimotive *BENOMIC STAR 260*. You are the owner of an first class piece of equipment that has been manufactured with great care. You will gain the most advantage from the equipment provided that you carefully follow the instructions given in this handbook with regard to safety, operating and maintenance.

Please study this user's handbook carefully before starting to use the *BENOMIC STAR 260*. Always follow the safety instructions and recommendations given in this handbook.

Berg Hortimotive does not accept liability for damage or indirect damage resulting from not following the operating and safety instructions contained in this handbook.

Neither does Berg Hortimotive accept liability whenever you or a third party make modifications to the pipe rail wagon or its accessories, without receiving prior written permission from the manufacturer.

The *BENOMIC STAR 260* is supplied in accordance with the conditions of sale of the Dutch METAALUNIE, as determined by the registrar of the law court of Rotterdam and in accordance with the most recent text contained therein. A copy of the terms and conditions of supply can be provided on request. You can also contact the Koninklijke Metaalunie, PO Box 2600, 3430 GA Nieuwegein, the Netherlands.





3.2 Suppliers information

In the event of breakdowns or defects occurring on the *BENOMIC STAR 260* please contact your Berg Hortimotive dealer.

4. Safety

4.1 Explanation of the safety terminology

Safety terminology

- Danger**  : Indicates serious or even fatal injury may occur if the instructions in the handbook are ignored.
- Warning**  : Indicates injury if the instructions described in this handbook are ignored.
- Caution**  : Indicates damage may occur to the equipment if the instructions described in this handbook are ignored.
- Warning**  : Indicates possible problems if the instructions described in this handbook are ignored.

4.2 Safety instructions

Read the following safety instructions carefully.

After reading the safety instructions they should be strictly observed at all times.

If the Pipe rail wagon safety instructions are not observed while it is being operated, it will become substantially more dangerous and may lead to serious physical injury.

DANGER! 

- **Carefully read all of the user's handbook. Observe the operating and safety instructions at all times.**
- **De BENOMIC STAR 260 is only suitable for operating on pipe rail systems that comply with the horticulture sector guidelines, the health and safety catalog in force in the Netherlands (see 7.2).**
- **The BENOMIC STAR 260 should only be used on the correct type of pipe rail system. Check that the centre-to-centre measurement of the rails and the pipe rail wagon correspond - see the pictogram on the platform.**
- **Never exceed the maximum load of 250 kg.**
 - 1 person including load (e.g. tools); see pictogram on the platform.
- **Never exceed lateral (sideways) manual force of 110N (11 kg traction).**
 - The BENOMIC STAR 260 should not be used for carrying out general maintenance activities.
- **The BENOMIC STAR 260 may only be used for maintaining crops in greenhouses.**
- **Using the BENOMIC STAR 260 when it is tilting more than 2° from the vertical (lengthwise and/or crosswise) is strictly forbidden.**
- **All loads should be secured and placed at the centre of the work platform.**
- **Only one person is permitted to stand on the platform at any time.**
- **It is prohibited to carry/lift passengers.**
- **It is prohibited to remove the safety rail.**

Increasing the lifting height in any way whatsoever is strictly forbidden.

- Always remain standing on the work platform

- **Keep a safe distance from fixed and/or moving parts within the greenhouse as well as cables and ropes.**
- **It is prohibited to pull steel cables or lay screens using the BENOMIC STAR 260.**
- **It is forbidden to use the BENOMIC STAR 260 as a crane.**
- **It is forbidden for either people or animals to enter the path on which the BENOMIC STAR 260 is being operated. Never operate more than one pipe rail wagon on the same path!**
- **When using the BENOMIC STAR 260 all the protective screens and covers and caps must be fitted and secured.**
- **Additional options, accessories and spares must be ordered and supplied exclusively by the manufacturer, Berg Hortimotive.**

Warning! 

- **Operating the BENOMIC STAR 260 may only take place when there are no other persons in the vicinity (apart from the operator) of the machine.**
- **The BENOMIC STAR 260 may only be operated by persons of 18 years or older who have received thorough instruction about the BENOMIC STAR, who are fully familiar with this instruction handbook and are completely aware of the dangers associated with operating the machine.**
- **The BENOMIC STAR 260 may only be operated once it has been correctly installed on the pipe rail system.**
- **All personnel working in the area of the BENOMIC STAR 260 should be made familiar with relevant safety rules and precautions that apply to the pipe rail system.**
 - Instructions from the employer.
- **Repairs to the BENOMIC STAR 260 may only be carried out by personnel who have received specific training from Berg Hortimotive.**
- **When carrying out maintenance on the scissor mechanism, the scissor blocks must always be put in place before starting (see 9.4).**
- **Never carry out repairs to the BENOMIC STAR 260 if it is already being operated by someone else. Always switch it off via the main switch before carrying maintenance activities and remove the charging plug from the wagon.**
- **Check the BENOMIC STAR 260 daily for defects and carry out maintenance frequently - see chapter 9: maintenance.**
- **Keep the operating controls and safety pictograms clean.**
 - operating controls and safety pictograms should always be clearly visible.
- **Once you have finished working with the BENOMIC STAR 260 always turn off the main switch.**
- **Never leave the BENOMIC STAR 260 unattended.**
 - Only when you have removed the key from the main switch.

- *It is forbidden to carry out modifications or make alterations to the BENOMIC STAR 260 without prior written permission from Berg Hortimotive.*
- *When leaving a path, you must first stop and check whether anybody is standing in the direct vicinity before continuing on the main path.*
- *It is forbidden to transport loose cargo with the BENOMIC STAR 260.*
- *When stacking loads ensure that they do not protrude more than 40 cm above the working platform. All loads should be properly secured.*
- *Before entering a path, ensure that there are no obstacles such as plant remains, etc lying on it.*
- *Never clean the BENOMIC STAR 260 with a water hose or steam cleaner.*
- *When moving the BENOMIC STAR 260 when not on the rails, the scissor mechanism should be fully collapsed.*
- *Never use the BENOMIC STAR 260 on the public highway.*
- *It is forbidden to step off the equipment before it has reached the lowest position.*
- *Observe the safety instructions for batteries - see Appendix 3.*
- *Always watch out for feet and toes when operating the lift on the BENOMIC STAR! The wagon is moved a few centimetres forward when put into position!*
- *It is mandatory to wear shoes with protective toe caps (S1).*
- *Remove the charging plug before using the BENOMIC STAR 260.*
- *After use, the direction switch must always be set at the neutral position.*

Please note! 

- **Always keep the workplace tidy.**
 - *An untidy working area can lead to dangerous situations.*
- **Always concentrate on the task in hand.**
 - *Always keep your wits about you when operating the Pipe rail wagon. Never operate the BENOMIC STAR 260 when you are unable to concentrate properly or when taking medicine whereby it is not advisable to operate machines or drive in traffic.*

4.3 Safety pictograms

On the *BENOMIC STAR 260* a number of safety pictograms have been applied. These pictograms warn the operator about possible dangers or dangerous situations. Always observe the warnings and contact your suppliers whenever the actual danger illustrated by the pictogram is not clear. Always make sure that the pictograms are visible and undamaged!

The *BENOMIC STAR 260* operator must have read and fully understood this handbook. When the operator does not understand the warnings given in either this handbook or on the machine (e.g. they speak another language), all the instructions, potential dangers, warnings and functions must be fully explained to them by a responsible person so that they can fully understand them.



Suitable for the pipe diameter stated with minimum thickness
 Suitable for the centre-to-centre pipe rail system measurement
 Maximum sideways manual force in Newtons (kg x10)
 Maximum total load in kg (maximum 1x person + moveable load)
 Maximum tilted position 2°
 Maximum support distance 1250 mm
 Only to be used indoors (in greenhouse)

The values depend on the type of *BENOMIC STAR 260*!

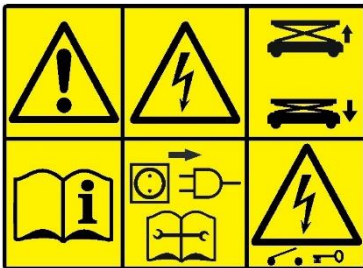

Beware! Read the handbook before using!
 Beware! Disconnect the power supply and consult the handbook when carrying out maintenance
 Upwards = scissor up, downwards = scissor down
 Main power switch: key vertical = ON, key horizontal = OFF
 Key can be removed by rotating further in the off position.

4.4 Residual risks

Despite the best possible design and the use of risk-reducing devices and the warnings about the dangers given in the handbook and applied to the machine itself, it is still possible that dangerous situations can arise. Beware of the following:

- Danger of hands, fingers, arms and head becoming trapped in the scissor mechanism!
- The danger of becoming trapped while standing under the wagon when depositing or picking up items with lifting system!
- The wagon falling over because of an incorrect pipe rail system!
- The wagon falling over because the maximum weight or manual force has been exceeded!



Beware: Electrical components!



Beware of the platform lowering!
 Always use the scissor blocks when working under or on the scissor mechanism!



Beware: Danger of becoming trapped!
 Keep hands away from the scissor parts!

5. Intended application

5.1 Area of application

The *BENOMIC STAR 260* has been designed for use in the greenhouse horticulture sector. The machine may only be operated by one person with a minimum age of 18 years who has received thorough instruction in the operation of the *BENOMIC STAR 260* and who is already familiar with the safety instructions and this handbook, both of which they have fully understood.

The *BENOMIC STAR 260* runs on pipe rails which have been installed according to the horticultural sector guidelines and is intended to be used as an aid for harvesting and/or maintaining the plants in a greenhouse. Use of the De *BENOMIC STAR 260* for any other purposes is strictly forbidden. The maximum loading may consist of one person plus a secured load which together should not exceed 250 kg in weight. The wagon may only be operated once it has been correctly installed on the pipe rail system. Pay extra attention when the scissor mechanism is descending ensuring that no people or objects can become trapped under or between the scissor mechanism. The platform may not be entered while the machine is on the concrete path. Always walk alongside the machine, therefore not on the chassis when transporting it over the main path.

5.2 Main components of the *BENOMIC STAR 260*

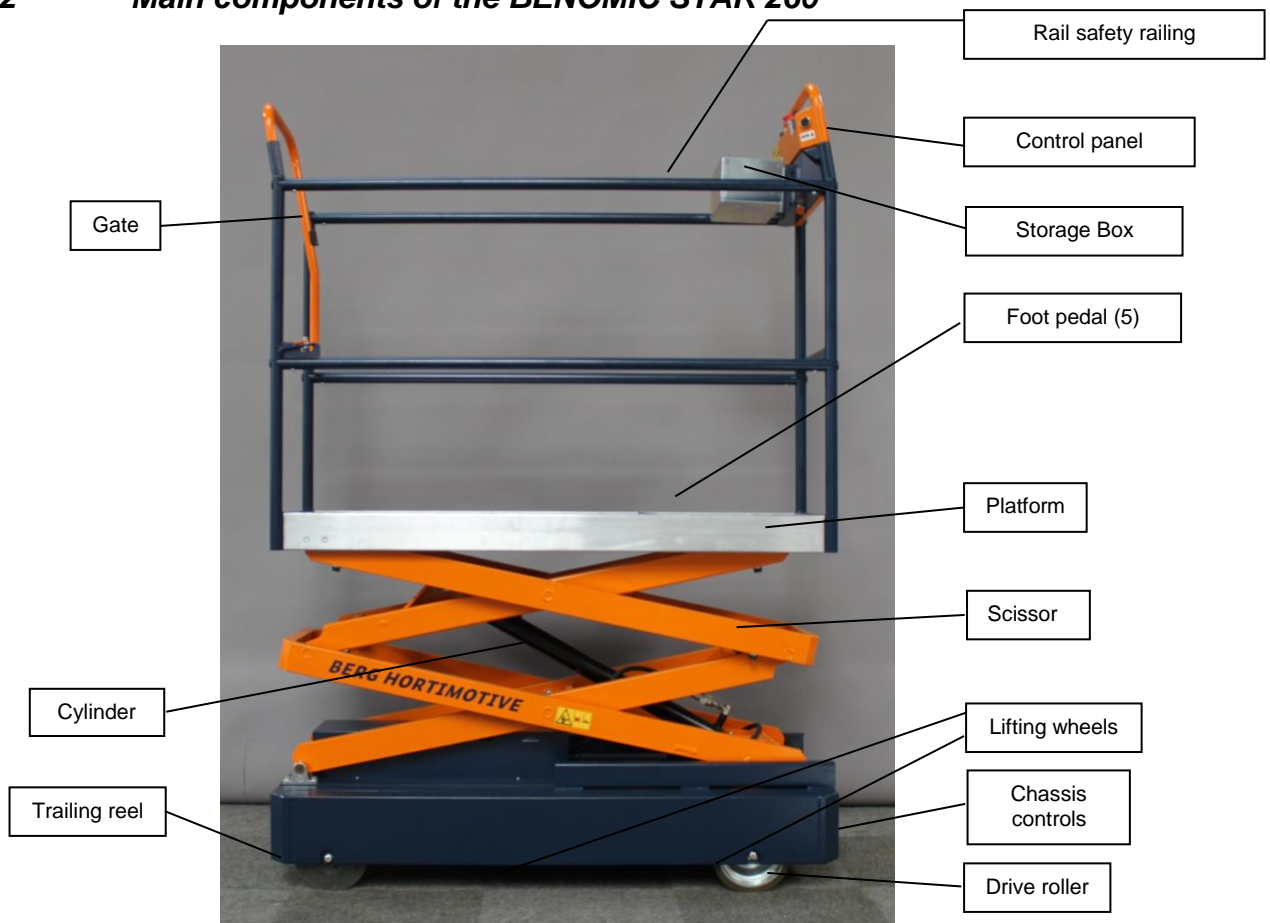

Figure 5.1; Names of the components on the upper part of the *BENOMIC STAR 260*

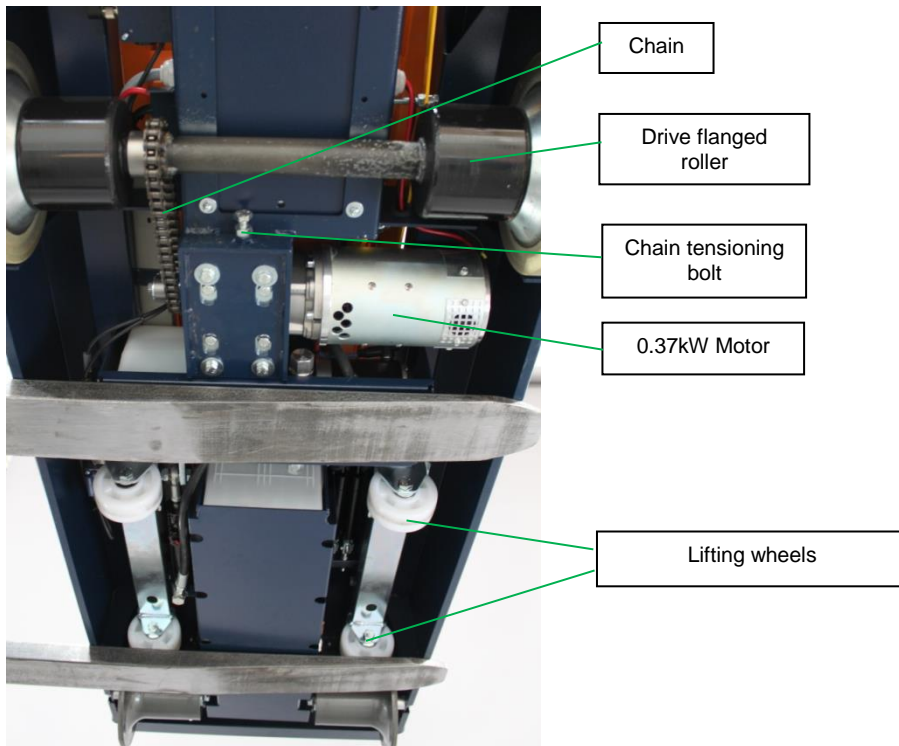
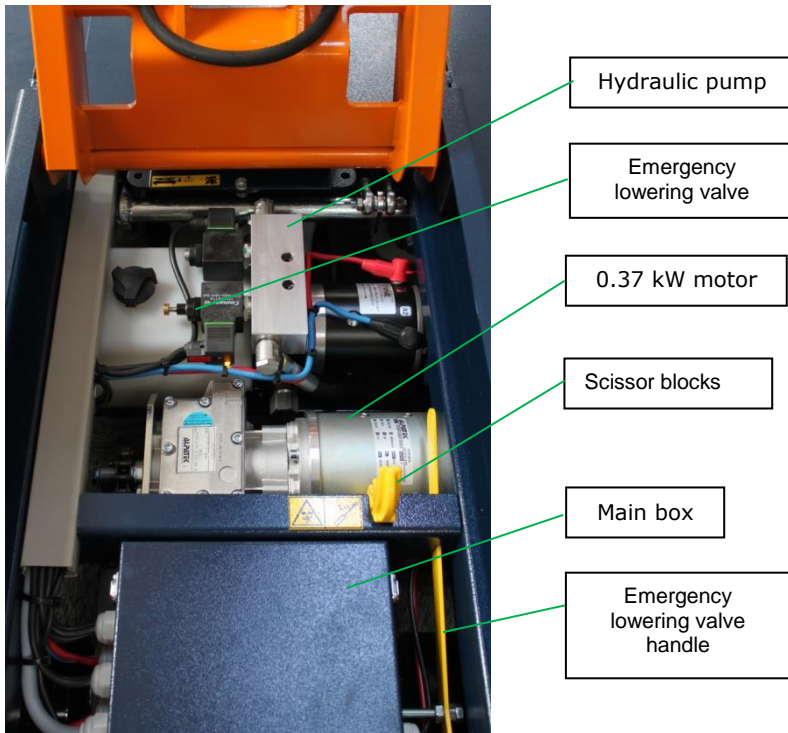

Figure 5.2; Names of the components on the lower part of the BENOMIC STAR 260

6. Transportation

6.1 External transport

When the *BENOMIC STAR 260* has to be transported, please do as follows:

1. Close the scissor mechanism fully.
2. Retract the lift wheels so that the wagon stands on the flanged rollers.
3. Set the direction switch to neutral (0) and the speed regulator to speed 0.
4. Switch off the *BENOMIC STAR 260* via the main switch (rotate the top of the red key to the horizontal position).
5. Secure the *BENOMIC STAR 260* properly so that it cannot move about, roll forward or tilt over.
6. Ensure that the *BENOMIC STAR 260* remains dry and frost-free during transportation.
7. When arriving at its destination, the *BENOMIC STAR 260* should be set up in accordance with the points described at chapter 7.1.

6.2 Internal transport

It is also possible to transport the *BENOMIC STAR 260* internally (in the greenhouse). It is preferred that the wagon is moved on the flange rollers and lift wheels, but it can also be moved by forklift truck for example. Moving with a forklift truck is done as follows:

1. Close the scissor mechanism fully.
2. Retract the lift wheels so that the wagon stands on the flanged rollers.
3. Switch off the *BENOMIC STAR 260* via the main switch (rotate the red key to a horizontal position).
4. Put the forklift truck forks as far apart as possible then push them under the wagon as far as possible.
5. Check the other side to see whether the forks stick out and are positioned at the centre of the *BENOMIC STAR 260*.
6. Secure the *BENOMIC STAR 260* to the elongation of the forks on the forklift truck so that wagon cannot move or slide off.
7. Lift the *BENOMIC STAR 260* carefully from the ground and no higher than is necessary.

Please note!

- **Never lift higher than necessary!**
- **Ensure that the forklift truck can lift at least 500 kg weight!**
- **Remove anything lying loosely on the platform before lifting!**
- **Drive slowly and carefully!**



7. Putting into operation

The *BENOMIC STAR 260* has been specially designed to run on a pipe rail system. When leaving the Berg Hortimotive factory, the pipe rail wagon is checked for proper functioning and safety. Before starting up the *BENOMIC STAR 260*, the items described at section 7.1 should be inspected.

The pipe rail system must comply with the requirements as laid down in the horticulture sector guidelines. The minimum specifications are given at Article 7.3 for the track width, pipe diameter and supports. These minimum requirements are also displayed on a pictogram (see 4.3) on the *BENOMIC STAR 260*.

These pipe rail specifications have been taken from the horticulture sector guidelines for pipe rail systems from the health and safety catalog in force in the Netherlands. For the complete contents of the policy regulation please contact the Ministry of Social Affairs & Employment.

7.1 *Inspection before starting operations*

The following points should be checked before starting up the *BENOMIC STAR 260*

- There are no loose electrical connections (all the functions and buttons work properly).
- No damaged cables and/or hydraulic hoses leaks.
- The drive roller, trailing reel and lift wheels are not damaged and run freely.
- The batteries are charged (see battery indicator 8.1, no 4).
- There is no general damage (specifically the scissor mechanism).
- There is no impairment to the visibility of the control components, pictograms and symbols.
- All the screens and protective caps and covers are firmly in place.
- The scissor mechanism is secured on the chassis and the safety railing to the scissor.
- The lifting system working properly.

7.2 *Horticulture sector guidelines for pipe rail systems*

The *BENOMIC STAR 260* has been designed to run on a pipe rail system. This means that there are rails on the paths between the plants which consists of two pipes of the same diameter and having a fixed width between them (centre-to-centre measurement). The pipes are often used as heating pipes and are supported along fixed distances. The pipe rail system must satisfy the most recent requirements of the horticultural sector guidelines for pipe rail systems. In Article 7.3, the minimum requirements are also given for the pipe rail systems which are taken from the sector guidelines for pipe rail systems. The pipe rail system on which the *BENOMIC STAR 260* is intended to be used, must also comply with these requirements. All the above-mentioned items should also be checked periodically according to the health and safety catalog in force in the Netherlands. It is absolutely prohibited to use a pipe rail system that does not comply with the sector guidelines or policy regulations. A number of tests are described in the policy regulations for determining whether it is possible to operate safely with the wagons on the pipe rail system. These tests should be implemented prior to working with the combination of the pipe rail wagon and the available pipe rail system.

7.3 Minimum requirements for the pipe rail system

The rails (normally heating pipes) must have an external diameter of either 51 mm or 45 mm and a wall thickness of at least 2 mm. The minimum material specifications for the pipes is as follows: Steel 37 (S235JR). The distance between the pipe rail system supports may not exceed 1.25 metres (centre-to-centre). When combining pipes with a diameter of 45 mm to a track width of 42 cm, the distance between the rail supports should not exceed 1 metre. The pipe rail supports used should be in accordance with, or equivalent to the following specifications: 1.5 mm thick steel base plate with reinforcing profile - base plate width of at least 115 mm - the length should be such that the base plate protrudes at least 70 mm from the two vertical supports which carry the load of the pipes. The centre-to-centre distance between the pipes should be at least 42 cm. The pipes must be properly secured, precisely installed and with a maximum tilt of no more than 2° in both length or in width. The pipes must also be properly attached to the supports and the concrete track. Loose fitting pipes must not be used! A soil test bore should be carried out using probing equipment (see policy regulation). It should have a so-called cone value on the top layer of more than 0.4 Mpa (62 psi).

Employing a pipe rail system that is not described in the policy regulation according to the health and safety catalog in force in the Netherlands is permitted provided that a stability test is carried out in accordance with the pipe rail system policy regulation according to the health and safety catalog in force in the Netherlands and where it appears that the combination of pipe rail trolley and pipe rail system in question is in fact stable. Furthermore, the supports for this exceptional pipe rail system must have a maximum spacing of one meter and the alignment variation in both length and breadth must not exceed 2 degrees.

→ The tubes are similar or at least equal to the specifications given in the table below.

The conditions for the axle load stand in the table below.

Cat.	Track-width [mm]	Tube-diameter / thickness [mm]	Support-distance [mm]	Permissible axle load at center to center size			
				420mm [kg]	500mm [kg]	550mm [kg]	600mm [kg]
1	420 t/m 600	51 / 2,25	max. 1000	507	548	573	593
2	420 t/m 600	51 / 2,25	max. 1250	406	438	458	475
3	420 t/m 600	45 / 2	max. 1000	345	372	372	403
4	420 t/m 600	45 / 2	max. 1250	276	298	276	323

→ Quality steel 37 (St37)

→ Wheelbase between 62.5% and 125% of the support distance.

→ All values for other pipe and tube rail supports should be calculated separately.

Source: *The Dutch health and safety catalog in force in the Netherlands*
<https://agroarbo.nl/catalogus/buisrailsysteem/>

7.4 Tilt alarm

The *BENOMIC STAR 260* is fitted with a tilt indicator alarm with an acoustic warning signal. The tilt indicator provides an acoustic signal when the machine is tilting over in excess of 2°. When this occurs all work being carried out must **stop immediately**, the **scissor mechanism** should be lowered as far as **possible**, and the operator should step off the *BENOMIC STAR 260* **then take it back** while walking beside it. Thereafter the pipe rail system should be adjusted before any activities can be restarted. First test the prepared section of rails with the scissor mechanism in the lowest position and at low speed. If there are no problems with this, test again with the scissor mechanism in the highest position at minimum speed. Normal activities can be restarted if no problems arise.

Always try to find a permanent solution to prevent the machine tilting on the rails!

8. Use

Ensure that you are familiar with the *BENOMIC STAR 260* and its control devices. Ensure that those using the *BENOMIC STAR 260* have received instruction for Pipe rail wagons and have read and thoroughly understand the safety instructions and have read this handbook.

- The *BENOMIC STAR 260* should only be used when the operator is certain that there is nobody in the nearby vicinity of the Pipe rail system.
- Always remove plant remains etc, and any other obstacles from the pipe rail system.
- Keep the wagon clean and regularly remove any waste materials. Before cleaning the wagon, switch it off by removing the keys from the contact.
- After using the *BENOMIC STAR 260* always remove the key from the contact.
- Service the *BENOMIC STAR 260* regularly and store it in a dry and frost-free environment if it is out of use over long periods.

Charge the batteries when the battery indicator remains in the red zone. If this occurs while working, there is normally enough power to last until the end of the day. When the acoustic signal repeatedly gives off 2 beeping noises, then the batteries on the *BENOMIC STAR 260* should be charged immediately. During charging, the charger must remain connected for approximately 12 hours until the charger indicates the battery is charged. (see the battery handbook for further information). Short battery charging periods during breaks, etc, must be avoided as they can cause serious damage to the batteries. Charging a battery before it is flat (battery condition meter still in the green zone) can shorten the life of the battery because each charging cycle wears out the battery - so avoid unnecessary charging!



BEWARE! Danger of injury with batteries:

Avoid the battery fluid (electrolyte) coming into contact with skin, wear safety goggles and gloves as this battery acid is highly corrosive. Wash with soap and water if it comes into contact. If it comes into contact with the eyes, immediately rinse in running water for a period of at least five minutes and call for medical assistance. Always ensure there is sufficient soap and water in the vicinity and that assistance is within calling distance when people have to work around batteries. Avoid short circuits (sparks), and ensure that there is no electrical connection between the battery poles. The battery cover should be in good condition. Bare patches or dents can cause short circuits!

Explosive gas is released while batteries are being charged. Always stay well clear with sparks, naked flames or cigarettes. Ensure that the place where batteries are charged and/or stored is well ventilated. Ensure that no metal objects can fall on top of the batteries as this could cause short circuits or sparks which could lead to an explosion.

Remove all personal objects including rings, bracelets, neck chains and wrist watches when working within the vicinity of batteries. For example, a short circuit could melt a ring resulting in serious burn injuries.

8.1 Controls

8.1.1 Controls on the chassis



Figure 8.1; Controls on the chassis of the BENOMIC STAR 260

1. MAIN SWITCH / EMERGENCY STOP

The *BENOMIC STAR 260* can be switched off and on using the main switch. When the key is in the vertical position (drive) the wagon is ON, and in the horizontal position (opposite of drive) the wagon is OFF. Whenever the *BENOMIC STAR 260* is switched on the battery condition meter also operates (see no 4). When the *BENOMIC STAR 260* is not being used or is being charged, the red key should be removed from the contact. The main switch also acts as an emergency stop. The wagon is completely switched off whenever the key is in the horizontal position.

Only switch on the *BENOMIC STAR 260* when the direction switch (6) is set to neutral and the speed regulator button (7) is at 0. If this is not done then the battery condition meter will display a start-up error by way of the flashing LEDs, so you must now put the direction switch and/or potentiometer to the neutral and/or RESET position in order to remove this start-up error.

2. SERVICE BUTTON SCISSOR CONTROLS

You can raise or lower the scissor with the scissor control selector switch without having to stand on the platform. Rotate the button clockwise (white strip at the top) and the scissor will rise for as long as the button is pressed. Rotate the button anticlockwise (white strip at the bottom) and the scissor will lower for as long as the button is pressed.

Please note!

- **Make sure that no people or objects can fall under or between the scissor mechanism when it is being lowered!**
- **Make sure there is sufficient space above the *BENOMIC STAR 260* when being raised!**
- **Never operate the button when somebody is on the platform!**



3. SOCKET FOR THE CHARGING PLUG

The batteries are charged using this plug. Always ensure that the plug is disconnected before starting to use the *BENOMIC STAR 260*! *Always remove the charging plug when carrying out maintenance.* Only a suitable charger should be used - see the specifications on the charger.

When the *BENOMIC STAR 260* is fitted with an internal battery charger (stated on the contact see figure 8.2) then only a 230 volt mains cable needs to be connected.

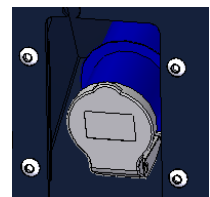
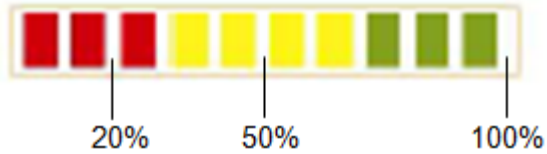

Figure 8.2; Internal battery charger!

4. BATTERY CONDITION METER



The battery condition meter gives information about the status of the battery. The battery is full when all the LEDs are lit - the fewer the LEDs lit up, the lower the battery charge. The LEDs are coloured green, orange and red. When the red, orange and green LEDs are all lit up the battery is 80% to 100% full – with only the red and orange LEDs it is 40% to 70% - and only the red LEDs means that the batteries have only 20% to 30% of the charge remaining. Charge the batteries when the battery indicator is in the red zone. If this occurs while working, there is normally enough power to last until the end of the day. When the acoustic signal repeatedly gives off 2 beeping noises, then the batteries on the *BENOMIC STAR 260* should be charged immediately. Switch off the *BENOMIC STAR 260* with the key switch and then charge the battery for at least 12 hours without interruption or until the battery charger indicates that the battery is full. (consult the battery charger handbook!) Avoid charging the battery when the battery condition meter is still showing at least 50% charge remaining. Always try to go down to approximately 20% state of charge before charging. This has the following advantages:

- Fewer charging cycles, increased battery life
- Lower water consumption
- Less energy consumed

When the battery condition meter LEDs all flash in turn, it means that the *BENOMIC STAR 260* has been started up wrongly. Make sure that the emergency stop is pulled out, then switch the main switch (1) OFF and then ON again. With the above, always put the direction selector switch (6) in neutral.

5. FOOT PEDAL

The foot pedal (5) is mounted in the platform (page 11), the *BENOMIC STAR 260* will drive in the desired direction as long as the foot pedal is actuated.

8.1.2 Controls on the platform

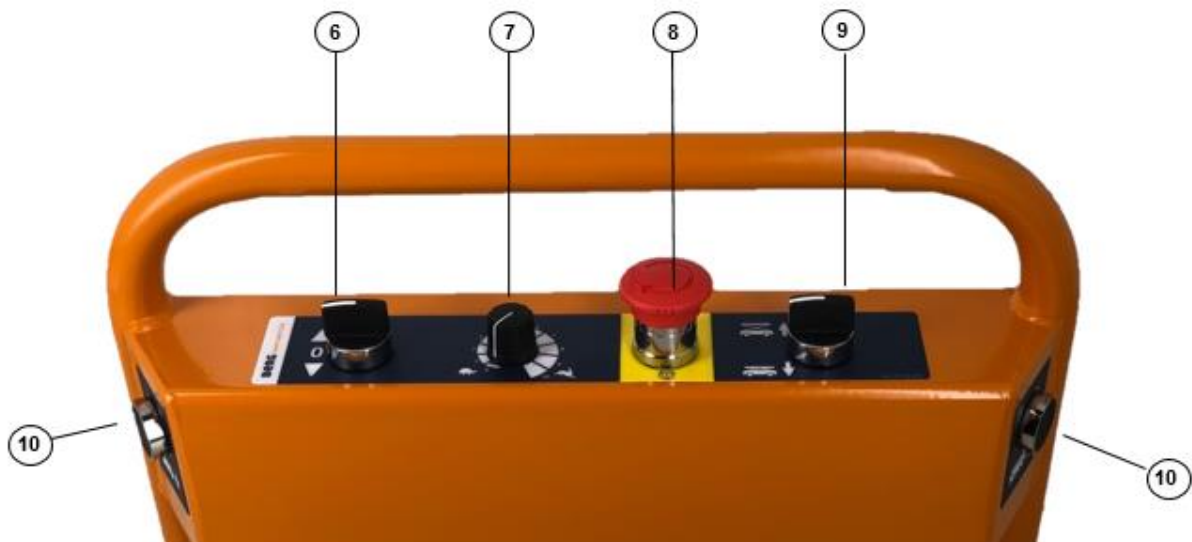

Fig. 8.3; Control panel

6. SWITCHING THE DIRECTION OF TRAVEL TO REVERSE

The direction of travel selected is determined by setting the selector to the desired direction. The switch has a central neutral position (0). When leaving the *BENOMIC STAR 260* unattended, always put the switch to the central position.

7. SPEED REGULATION BUTTON

0 = standstill 10= maximum speed

Put this button to 0 for switching on the BENOMIC STAR!

8. EMERGENCY STOP

Only to be used in emergencies! Use only the main switch (1) for switching off.

- Press = stopping and switching off
- Turn and pull = releasing

Only release the emergency stop when the direction switch (6) is set to neutral and the speed regulation button (7) is at 0.

9. WORK PLATFORM LOWERING/RAISING, ROTATING SWITCH

The work platform can be raised and lowered using the rotating switch. The platform lowers for as long as the button is turned downwards in an anticlockwise direction.



Beware of people or objects in the vicinity of the scissor mechanism when lowering!

The scissor mechanism rises to a maximum platform height of 2,6 metres by pushing the button clockwise and upwards.

10. RAISING THE WAGON HYDRAULICALLY

Press button (11) to raises the *BENOMIC STAR 260*, after which it can be manually turned and moved.

The press-button on the right hand side (11) is for extending the lifting wheels. (wagon up)

10. HYDRAULIC LAYER OF THE CAR

Press button (10) to complete deposition of the *BENOMIC STAR 260*.

The press-button on the left hand side (10) is for retracting the lifting wheels. (wagon down)

Please note!

- ***Only raise the platform on flat ground (concrete path or main path) and never do this on the pipe rails or on a sloping surface.***
- ***Allow the platform to completely lower before raising the BENOMIC STAR 260!***
- ***Beware of toes and fingers when lowering the BENOMIC STAR 260!***



8.2 Emergency lowering valve

The emergency lowering valve is located below the scissor under the cover. When the scissor cannot be lowered any further via the controls on the platform (9) or via the controls on the top side of the *BENOMIC STAR 260* (2) the cover should be removed by slackening the bolt and removing the plate between the scissor legs. Next, the emergency valve can be pressed in using the handle supplied. **Beware of hands, arms or head becoming trapped between the scissor mechanism or under the platform!**

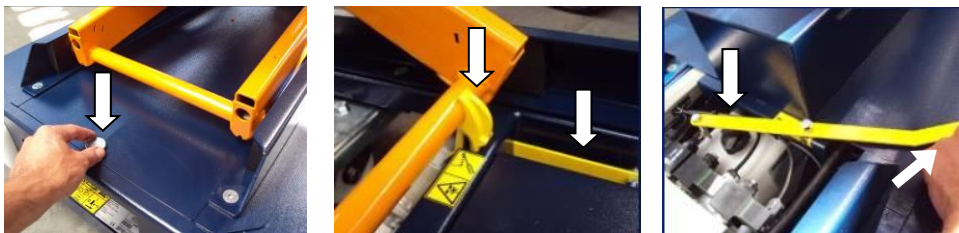

Fig. 8.4; Left: slacken the bolt and remove the cover. Centre; raise the safety catch & remove the handle. Right; Put the bolt in the hole press it against the pin in the emergency lowering valve!

Beware! Stop before your hands become trapped! Only use this function in emergencies!



8.3 Moving the *BENOMIC STAR 260* on the main path

There are two ways of moving the *BENOMIC STAR 260* along the main path. Always walk beside the wagon - never in front of it! The first method is on the flange rollers. Set the direction of travel (max speed setting 4). Press the foot switch and the *BENOMIC STAR 260* moves in the direction selected.

The second method is to put it onto the lift wheels. Press button 11 and the *BENOMIC STAR 260* is raised by the lift wheels. The *BENOMIC STAR 260* is now easy to turn around and move off sideways. **Never let the *BENOMIC STAR 260* stand on the lifting wheels and always walk beside the wagon!**

8.4 Out of use

When the *BENOMIC STAR 260* is not being used, please ensure that the scissor is in the lowest position and the lift wheels are retracted so that it is sitting on the flanged rollers. Switch it off via the main switch and store it in a dry and frost-free area **with fully charged batteries**. It is recommended to connect the batteries on the *BENOMIC STAR 260* to a trickle charger. If this is not possible, the batteries should be charged at least every month (also when the *BENOMIC STAR 260* is stored for longer periods. Ensure that the ground underneath is level. If after a long period the *BENOMIC STAR 260* is put back into operation, it should first be inspected as described at chapter 7.1 (Inspection before starting up).

8.5 Cleaning

Regularly remove any remains of plants, leaves, etc, and brush off any sand and dust. Clean the Pipe rail wagon with a dry/damp cloth and soft brush. It is also possible to clean the *BENOMIC STAR 260* using compressed air, provided that it is dry. Never pour water over the *BENOMIC STAR 260* or clean it using a steam or high-pressure water cleaner which can lead to serious damage being caused to the electrical circuits in the equipment. *Every week remove all sand and dirt from the chassis for the scissor sliding blocks.* See also Appendix 4: Cleaning the powder coating

8.6 Problems, causes & solutions

Problem A : The *BENOMIC STAR 260* does not move.

Cause : **Key switch is at the OFF position**

Solution : Turn on the key switch (vertical position)

Emergency stop locked on

Unlock emergency stop

Batteries flat (red LEDs on the battery condition meter flashing 2x red LED)

Charge batteries

Speed meter at 0

Set a minimum speed

Travel direction in neutral

Choose a direction

Error (LEDs flashing alternately)

See no 1 on page 18

Battery terminals making poor contact

Clean battery posts, refit battery terminals

Faulty foot switch

Replace the foot switch, consult dealer

Broken cable at foot switch.

Repair break in cable or replace switch

Lift does not retract enough or faulty limit switch

Fully retract (10) the lift (system) or check the limit switch

25 amp safety fuse in 0 position.

Consult your dealer

Other causes.

Consult your dealer

Problem B: The platform will not go up or down.

Cause : **Lift system limit switches not connected/defective.**

Solution : Fully retract the lift system or check the limit switch

Batteries flat (red LEDs on the battery condition meter flashing 2x red LED)

Charge batteries

Battery terminals making poor contact.

Clean battery post, refit terminals

Key switch set at off

Turn on the key switch (vertical position)

Emergency stop button pressed in

Release emergency stop

Overloaded

Reduce the load. Max. 250 kg

Hydraulic fluid level too low

Top up hydraulic fluid (scissor up, info from supplier)

Defective switch

Try the main button for scissor control next the main switch

Fuse 80 amp defective

Consult your dealer

Control current 6.3A fuse is blown

Consult your dealer

Problem C: Speed difficult to regulate

Cause C : **Speed regulator switch is faulty**

Solution : **Consult your dealer**

Drive motor regulator is defective

Consult your dealer

Problem D: BENOMIC STAR 260 has fallen over.

Cause D : - **Careless transportation**
- **Unstable pipe rail system**
- **Manual force too great**
- **Overloaded**
- **Tilt indicator ignored**
- **Riding next to the pipes on concrete path**
- **Lifting onto pipes or uneven ground surface**

Solution : 1. **Disconnect wagon**
2. **Right the wagon**
3. **Remove the covers**
4. **Disconnect the batteries**
5. **Clean the wagon**
6. **Examine the damage**
7. **Find the cause and a solution (remove)**
8. **Examine according to table in chapter 7**
9. **Check according to 7.1**

!!!BEWARE of fluids, battery acid is extremely corrosive!!!

8.7 Dismantling

When you have to dispose of your *BENOMIC STAR 260* you should return it to your dealer or a company that specialises in dismantling vehicles. Never take your *BENOMIC STAR 260* to a scrap metal dealer or a waste dump. The *BENOMIC STAR 260* should be dismantled and the chemical components removed (hydraulic oil and batteries).



Faulty batteries should be handed into the local authority or your supplier.
Oil should be handed in as chemical waste.



9. Repairs & maintenance

The *BENOMIC STAR 260* is a very high quality product. In order to guarantee that the high quality remains, it is vital that the maintenance schedule given below is strictly adhered to. Repairs and maintenance activities should be recorded in the maintenance logbook - see Appendix 1. The employer is also responsible for periodically checking tools and equipment according to the current Working Equipment Guidelines that cover this.

Switch off the *BENOMIC STAR 260* at the main switch before starting maintenance:

Maintenance - Checks	Tools	Daily	Weekly	Monthly	Yearly
Sufficiently charged battery	Battery condition meter	X			
Damage to control components	Visually	X			
Damage to/visibility of pictograms & stickers	Visually	X			
Foot pedals + platform cleaning	Brush / damp cloth		X		
Cleaning control panel	Soft brush / damp cloth		X		
Clean the scissor sliding blocks on chassis	Brush / damp cloth		X		
Check for leaks and damaged cables and hoses	Visually		X		
Check for ingrained dirt or string wrapped around wheels and chain	Visually		X		
General mechanical damage	Visual		X		
Check the lifting gear in both directions for sticking (low hydraulic fluid level)	Hydraulic fluid ISO Viscosity Grade 46		X		
Charge batteries if necessary or at least 1x monthly	Battery charger			X	
Check battery fluid levels (1 cm fluid covering plates - see Appendix 3)	Distilled water, gloves & safety goggles			X	
Check operation of the tilt indicator	Testing > 2 degrees			X	
Check hydraulic components under the cover for leaks (pump/valves)	Tool for removing bolt from cover			X	
Lubricate lift wheels, drive chain and bearings	Bearing grease, chain grease or other universal lubricants			X	
Check chain tension (see 9.6)	Open-ended spanners			X	
Locking ring mounting on the scissor shafts	Visually			X	
Have the motor's carbon brushes cleaned and those smaller than 1 cm replaced (see 9.5)	Compressed air / Visually				X
Lubricate hinged components on the scissor mechanism (see 9.4)	Grease gun and grease				X
Lubricated hinged parts on lifting system	Grease gun / grease				X
Check the welds on the scissor construction for (hair)cracks and rust.	Visually				X

If the above checks indicate that there is a fault with the *BENOMIC STAR 260*, immediate contact should be made with the *BENOMIC STAR 260* dealer. Continuing to use the machine after identifying defects could lead to dangerous situations and is therefore forbidden!

9.1 Specialist maintenance

Maintenance and repairs to the items listed below may only be carried out by qualified specialists appointed by Berg Hortimotive:

- Work on electrical components and wiring (except replacing foot pedal).
- All work concerning the hydraulic system.
- All activities to the drive motor excluding: cleaning, readjusting or replacing the chain or chain sprockets.

9.2 *Maintenance and inspection by the operator*

All the work given in the above table that is not excluded at item, 9.1 Specialist Maintenance, must be carried out periodically. Some of the actions are described below. You will find instruction film clips on our website that show how certain maintenance activities should be carried out.



www.berghortimotive.com

9.3 *Berg Service Alert*



Berg Service Alert

Berg Hortimotive takes customer satisfaction very seriously. A satisfied customer is the best ambassador for our products and company!

No matter how well we manufacture our products, after a period of time they are going to need servicing and maintenance carried out. Like most people, you also know that a good maintenance schedule considerably increases the lifespan of the product. So that we can provide you and our dealers with even better support, Berg Hortimotive has started sending out the “Berg Service Alerts” (BSA).

BSA means that you can expect an email from us periodically that contains a link that takes you to a page with lots of tips and recommendations for maintaining the same Berg Hortimotive products that you own and operate. We include pictures and images as much as possible so that the information is easy to understand and apply.

Our tip: Visit our website and subscribe to BSA!

If as a result of these tips and recommendations you come across maintenance work that you are either unable, or do not want to carry out, please consult our extensive dealer network to find assistance. The dealers are trained by us on a regular basis and therefore have the necessary knowledge, experience and access to the original spare parts for providing you with assistance quickly and efficiently.

9.4 Maintenance in and around the scissor mechanism

The scissor blocks supplied with the machine must always be used for maintenance activities in and around the scissor mechanism. Remove the capping. Unlock the catch with the scissor raised (illustration A). Lower the scissor (B) until it is next to the safety catch (C). Now switch off the *BENOMIC STAR 260* at the main switch.



Figure 9.1 A-B-C; Unlocking the scissor blocks

The scissor shafts are fitted with bush bearings. The inner scissor components are connected to the outer components by a shaft. To prevent the shafts becoming rusted, they should be lubricated at least once a year using a universal grease and grease gun. Raise the scissor and then block it as described at scissor blocking (see illustration 9.1). Put the grease gun over the nipples and pump in the grease until it comes out at the sides of the bush.



Figure 9.2; Location of the grease nipples for the scissor shafts

Figure 9.3; Location of the grease nipples at the cylinder

9.5 Inspecting the carbon brushes

1. Raise the *BENOMIC STAR 260* thereby making the motor accessible. 2. Blow the carbon brushes clean with compressed air 3. Unscrew the grill, 4. Pull up the carbon brush, 5. Carbon brushes less than 1 cm long should be replaced - consult your dealer.



Figure 9.4; Inspecting carbon brushes in the motor

9.6 Chain tensioning

The chain tension should allow approximately 1 cm of play - if this is not the case, please do the following:

1. Switch off the *BENOMIC STAR 260* at the main switch and remove the key from the contact to prevent the *BENOMIC STAR 260* from being started up.
2. Raise the wagon using a forklift truck for example and then secure it so that it is safe for carrying out activities. (see 6.2 Internal transport)
3. Unscrew the 4 motor retaining nuts approximately a half turn (A)
4. Unscrew the tensioner locking nut (B)
5. Tension the chain by turning the adjuster bolt (C) until the play on the chain is approximately 1 cm (D)
6. Lock the adjuster bolt by tightening the locking nut (B)
7. Tighten the 4 motor retaining nuts again (A)

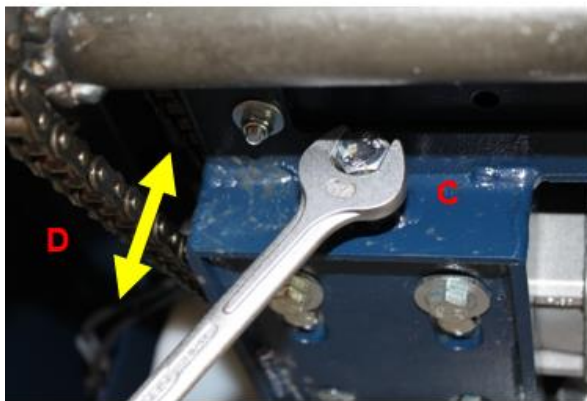
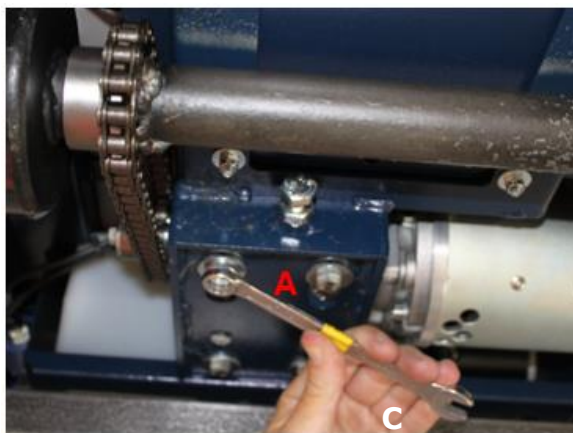

Figure 9.5 A-B-C; Tensioning the chain

9.7 Adjusting fall velocity of scissors platform

The fall velocity can be adjusted as required with the speed control valve, with the standard factory setting the platform falls from the top position to the lowest position in approx. 20 seconds.

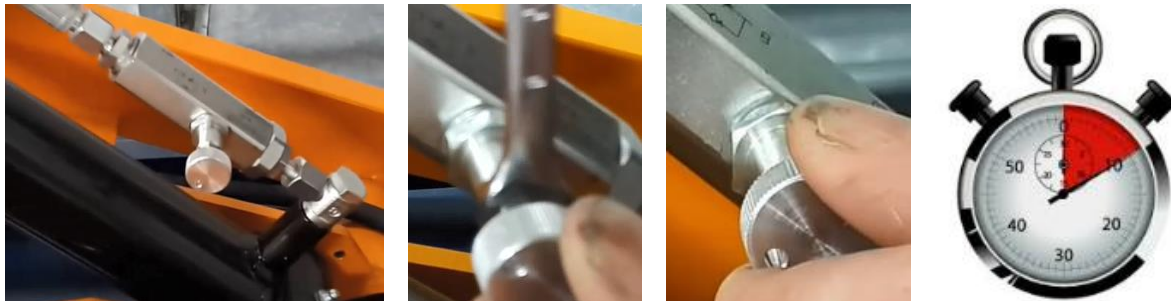
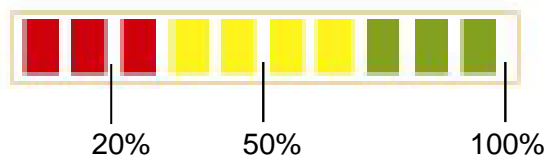

Figure 9.6: Adjusting scissors platform fall velocity

1. Lift the platform so that the speed control valve is accessible, 2. Unscrew the lock nut with an 8 mm spanner, 3. Turn the adjusting screw clockwise for a slower and anticlockwise for a faster fall, 4. Check the result and 'time' the fall velocity to see if it is as required, **(fall time no shorter than 18 sec.!) 5. Adjust all trolleys with this new fall velocity, 6. Tighten the lock nut again!**

9.8 Charging the batteries

Charge the batteries according to the status of the battery condition meter when they have between 50% and 20% remaining capacity, but try to do this as often as possible when the status is around 20% in accordance with the following recommendations.



BATTERY CONDITION METER (4)

The battery condition meter gives information about the status of the battery. The battery is full when all the LEDs are lit - the fewer the LEDs lit up, the lower the battery charge. The LEDs are coloured green, orange and red. When the red, orange and green LEDs are all lit up the battery is 80% to 100% full - only the red and orange LEDs 40% to 70% - and only the red LEDs means that the batteries has only 20% to 30% of the charge remaining. When the status is red, you can continue working although the batteries should be charged as soon as you have finished working! When the acoustic signal repeatedly gives off 2 beeping noises, then the batteries on the *BENOMIC STAR 260* should be charged immediately. Switch off the *BENOMIC STAR 260* with the key switch and then charge the battery for at least 12 hours without interruption or until the battery charger indicates that the battery is full. (consult the battery charger handbook!)

Avoid charging the battery when the battery condition meter is still showing at least 50% charge remaining. Always try to go down to approximately 20% state of charge before charging. This has the following advantages:

- Fewer charging cycles, increased battery life
- Lower water consumption
- Less energy consumed

Regardless of the level of usage, charge the batteries at least once a month using a suitable charger! Prevent the batteries becoming deeply discharged which can lead to serious damage and shorten the battery lifespan!

See also the instructions in Appendix 3 battery safety sheet!

9.9 Pipe rail system maintenance

The pipe rail system on which the *BENOMIC STAR 260* runs should be checked on a regular basis. The system should always satisfy the Horticulture Sector Guidelines for Pipe Rail Systems in greenhouses (see 7.2). It is prohibited to use the Pipe rail wagon on a pipe rail system that does not satisfy these guidelines. The employer is also responsible for periodically checking tools and equipment according to the current Working Equipment Guidelines that cover this.

Ensure that all the pipes have sufficient support with a maximum separation distance of 1.25 m in between and that the supports are not out of line with respect to the pipes. Moreover, the pipes on the concrete path should be secured and must not be loose. At the pipe ends (in front of the wall) there should be an end-stop welded on that is at least 5 cm high - at the end of each season check whether the stops are still functioning properly. The ground under the pipe rail system should be dry, flat and hard. Soft or damp spots should be repaired and surface indentations permanently repaired.

10. Technical specifications

BENOMIC STAR 260 pipe rail wagon with hydraulic scissor and lifting system

Type: 5200.xx.xxxx / S514.xx.xxxx	2-scissor mechanism
Dimensions [mm]:	
Centre-to-centre	420-800
Length	1500
Breadth	c-to-c + 180
Chassis step-up height from concrete path	266
Step-up height to platform in lowest position	556
Height of control panel from platform	1180
Length of work platform	1500
Width of work platform	420
Maximum work platform height	2620
Max. Load capacity [kg]	250
Maximum lateral pressure [N]	110
Weight [kg] (c-to-c 550)	370
Motor power Moving [kW]	0.37
Hydraulic motor capacity [kW]	1.2
Hydraulic system pressure [bar]	200
Hydr.fluid Visc. 46 [L]	1.5
Maximum speed on rails [m/min]	57
Maximum speed on concrete path [m/min]	112
Min. lifting speed [m/sec.] *	0.14
Min. lowering speed [m/sec.] *	0.15
* with a load of 80 kg	
Voltage [Volt DC]	24
Battery capacity [Ah] (5h/20h)	120 /159
Noise level [dB]	<70
Wheelbase [mm]	1109

Physical operating conditions

Ambient temperature,	
Transport & Storage	: 5 to +40 degrees Celsius
Working	: 5 to +40 degrees Celsius
Rel. Humidity (RH)	: 0% to 90%, <u>not condensing</u>
Lighting	: Normal ambient lighting.

The machine is not designed to be used outdoors.
The machine is not suitable for operating in explosive atmospheres.

11. EG Declaration of Conformity

(according to Appendix IIa of the Machinery Directive)

Berg Hortimotive
Burg. Crezeelaan 42a
2678 KZ De Lier - Holland
T: +31 (0)174 – 517700
www.berghortimotive.com

While taking full responsibility, we hereby declare that the product:

- ***Pipe rail wagon type BENOMIC STAR 260 with twin hydraulic scissor mechanism and hydraulic lifting wheels***

Article number:

Serial number:

- Meets the requirements of the new Machine Guidelines 2006/42/EG

Satisfies the following EU Directives:

- Electromagnetic Compatibility Directive (EMC), 2004/180/EG (according to the latest edition)
- Low Voltage Directive 2006/95/EG (according to the latest edition)

Satisfies the following harmonised standards:

- [1] NEN-EN 953:1998+A1 Ontw. Draft Machine Safety. General requirements for the design and construction of safety equipment (fixed, moveable), CEN
- [2] NEN-EN 60204-1:2006, Safety of machines – Electrical equipment on machines – Part 1 : General requirements

Conforms to the Dutch health and safety catalog in force in the Netherlands.

the Netherlands, De Lier, date

Director or authorised signatory. Martin van Lierop

Appendix 2: Technical drawings

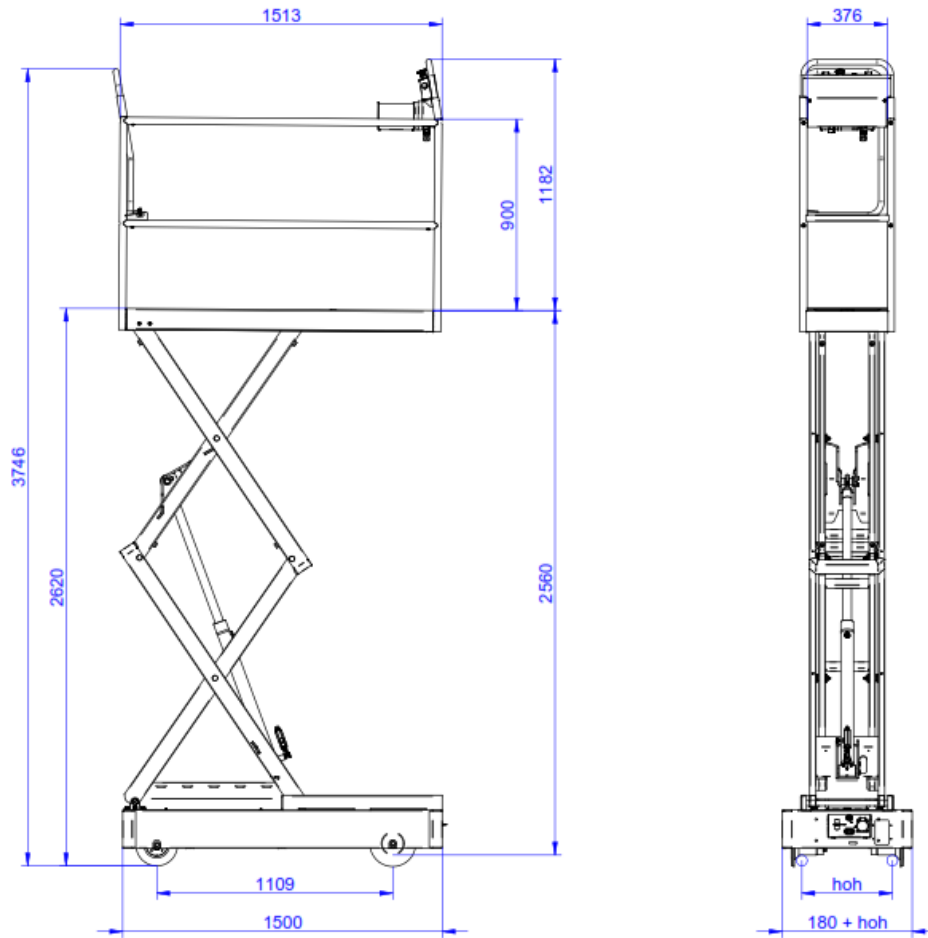

Fig. 2.1; Maximum dimensions 2-scissor in mm

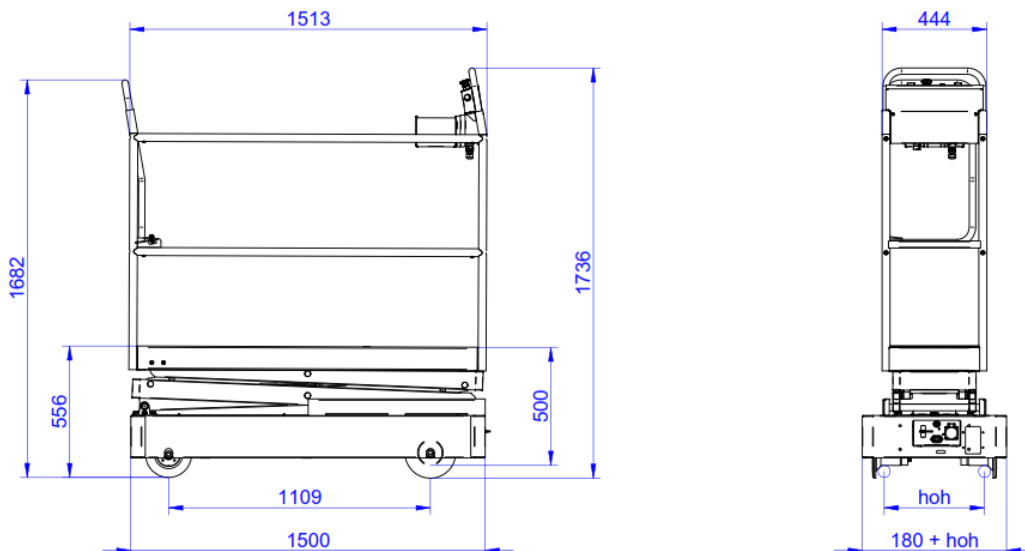

Fig. 2.2; Minimum dimensions 2-scissor in mm

Appendix 3: Battery safety sheet

Battery recommendations

The following chapter provides recommendations for efficient usage, safety and maintenance.

Efficient use of the pipe rail wagon and the batteries

The following recommendations are aimed at facilitating the efficient use of the pipe rail wagon and to improve the life-cycle of the batteries.

Basic principles:

- The battery goes flat sooner when running at higher speeds.
- High levels of starting and stopping also increase electrical energy consumption.
- Through using the pipe rail wagon, the remaining capacity and battery voltage gradually reduces, while simultaneously the current consumption increases. This results in increasing heat generation from the motor and speed regulator as the batteries gradually lose their charge.
- Worn rollers, string around wheels, etc, and rusty chains (poor maintenance) all result in higher energy consumption. (for maintenance instructions, see website: <http://www.berghortimotive.com/service/bsa-film>)
- Allowing batteries to go completely flat also reduces the life-span.
- Charging when required and good maintenance help to increase the life-cycle of the batteries.
- Charging when required also lowers the generation of heat in the motor and speed regulator, as well as the battery charger.

Efficient usage:

- Try to match the speed as closely as possible with the work tempo (potentiometer).
- By following the above recommendations, the productivity of the workers will increase.

Safe use of batteries

Below are recommendations for usage and maintenance.

BEWARE!

- **Explosive gas is created while the batteries are being charged, therefore no fires, naked flames or smoking are permitted!**
- **Charging should only take place in well ventilated spaces!**
- **The battery fluid levels must be checked at least once a month! The battery fluid must be at least 1 cm above the level of the plates**
- **Top up batteries with distilled water (demineralised) only - always wear gloves!**
- **Always top up the batteries AFTER charging and never fill higher than the level marker in the cell opening. (see also the instruction sheet for traction batteries)**



Discharging the battery to less than 20% of its capacity has a negative effect on both the battery and the charger. Only charge the batteries when the battery condition meter is in the red zone, this is beneficial for the lifecycle of the batteries, electric motor and the drive regulators! Always recharge a flat battery immediately, as this increases the life-cycle substantially. It is important to check the specific gravity of the battery acid at least once a week, though it should certainly be done each month using a hydrometer (fig. A+B and table below).

The specific gravity of a fully charged battery should be 1280 g/l:

100%	sg 1280 g/l	=	12.7 volts
80%	1240		12.5
60%	1210		12.3
40%	1170		12.1
20%	1140		11.9

Before charging, disconnect the *pipe rail wagon* at the main switch. When charging batteries, always connect them to the charger before switching it on. After the batteries have been charged, switch off the charger first, then disconnect the batteries.

Overcharging can cause damage to the batteries through boiling the battery acid dry. It is advisable to use a modern battery charger with an automatic cut-off - these are available from Berg Hortimotive. **Only use a charger type that is suitable for the batteries being charged! (see charger instructions)**

The charging process should never be interrupted - charging should be completed - see the charge indicator.

When charging batteries, do not make repairs to the *pipe rail wagon* nor carry out cleaning or any other activities.

Turn off everything that consumes electricity before removing the batteries - this reduces the possibility of creating sparks.

Always disconnect the earth cable (-) first when removing the batteries. When reinstalling the batteries, connect the earth cable (black) last.

WARNING!

Always connect the positive terminal (+ = red) to the positive pole and the negative terminal (- = black) to the negative pole on the battery.

Battery fluid is corrosive - avoid contact with clothing, skin and eyes.

Wash battery acid splashes on clothing or skin immediately with soap and water - thereafter thoroughly rinse in running water.

Any acid splashes to the eyes must be rinsed for at least 5 minutes in clean water and a doctor consulted immediately!

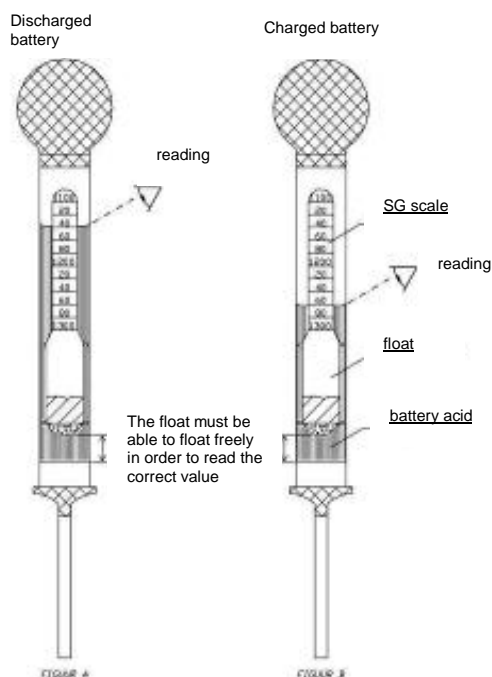

Note

Check the amount of chargers that can be connected to one group. This can be calculated by multiplying the amperage by the voltage. E.g.: $16A \cdot 230V = 3680W$

Now check the output of the battery charger. Divide this total amount by the output of the battery charger. E.g.: $3680/700 = 5.25$. In this case 5 battery chargers can be connected.

Also check whether the voltage at the charging location corresponds with the required voltage stated on the battery charger. Long cables can lead to voltage drop. If this is the case please consult your dealer.

Check whether it is a suitable charger for your machine. The battery specifications suitable for the charger are stated on the charger itself or in the charger handbook!

Only use chargers suitable for charging 24V-110Ah/5h wet batteries! (see charger instructions)

	TREM-CARD	<div style="border: 2px solid black; padding: 5px; display: inline-block;">UN 2794</div>
---	-----------	--

Substance Batteries wet, filled with acid, electric storage

UN Number 27

HIN 80

ADR Label 8

ADR Class 8

Packing group -

Emergency Response Information

CORROSIVE SUBSTANCE

1. Characteristics

- Corrosive, causing damage to skin, eyes and air passages
- Not flammable

2. Hazards

- Heating of container(s) will cause pressure rise with risk of bursting and subsequent explosion (BLEVE).
- Gives off corrosive and irritant fumes, also when burning
- May attack metals and produce hydrogen gas which may form explosive mixture with air
- The vapour may be invisible and is heavier than air. It spreads along the ground and may enter sewers and basements

3. Personal protection

- Chemical protection suit.
- Respiratory mask equipped with ABEKP1 filter

4. Intervention actions

4.1 General

- Keep upwind. Put on protective equipment before entering danger area.



4.2 Spillage

- Stop leaks if possible.
- Dilute spillage with water spray as far as necessary to reduce hazard. Contain run off by any means available.
- If substance has entered a water course or sewer, inform the responsible authority.
- Ventilate sewers and basements where there is no risk to personnel or public

4.3 Fire (involving the substance)

- Keep container(s) cool with water
- Extinguish with water fog (spray)
- Do not use water jet to extinguish
- Use water spray to knock down fire fumes if possible
- Avoid unnecessary run-off of extinguishing media which may cause pollution.

5. First aid

- If substance has got into eyes, wash out with water for at least 15 minutes and seek immediate medical attention.
- Remove contaminated clothing immediately and drench affected skin with plenty of water.
- Persons who have been in contact with the substance or have inhaled fumes should get immediate medical attention. Pass on all available product information.
- Mouth to mouth resuscitation should be avoided. Use alternative methods, preferably with oxygen or compressed air driven apparatus

6. Essential precautions for product recovery

- Use acid resistant equipment
- Recover spilled product in vented container fitted with absorption filter

7. Precautions after intervention

7.1 Undressing

- Drench contaminated suit and breathing apparatus with water before removing facemask and suit.
- Use chemical protection suit and self-contained breathing apparatus while undressing contaminated co-workers or handling contaminated equipment.

7.2 Equipment clean up

- Drench with water before transporting from incident.



INSTRUCTIONS TRACTION BLOCKS



Daily maintenance EW159T:

- Only discharge the battery to 80% maximum (Electrolyte level 1130 SG)
- Connect the battery to the charger, switch on charger and charging should start automatically
- Do not disconnect the battery until charge cycle has finished
- When charge cycle has completed make sure charger is switched off before disconnecting the DC plug

Weekly maintenance EW159T:

- Check the level of the Electrolyte on the battery
Only top up battery with demineralised water
- Only top up after charge cycle has completed
- The battery should only need topping up every 2 weeks
- If required more frequently please contact the manufacturer
- Check for signs of corrosion on cables or bolts clean as required
- The battery tops should be kept clean and dry
No smoking or naked flames to be in the area of charging

Only top up the battery after the charging cycle has been completed to avoid electrolyte spilling from the battery!
No smoking or naked flames to be in the area of charging.

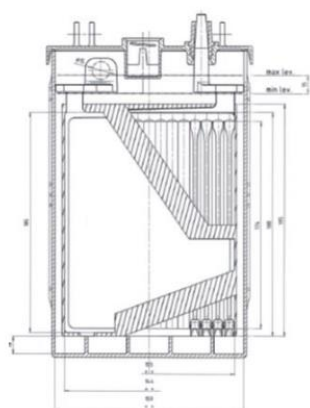

Green is maximum level

Red is minimum level



Always follow the manufactures instructions



No smoking or naked flames



Electrical Hazard



Danger risk of explosion



Always wear the correct PPE



Avoid contact of skin and eyes



Room must be well ventilated



All disused batteries must be recycled

Berg Hortimotive BV
Burg. Crezeelaan 42a 2678 KZ DE LIER

T : 0174- 517700
F : 0174- 516958

E : info@berghortimotive.nl
I : www.berghortimotive.nl

Appendix 4: Cleaning the powder coating

The importance of cleaning and maintenance:

- It retains the appearance and image of the product over a longer period.
- It extends the life-span.
- It prevents corrosion.
- It helps prevent the spread of plant diseases.
- It stimulates employees to operate the machines with care.

Removing contamination periodically prevents any chemical substances that may be present from affecting the powder coating. The protective layers are vulnerable to acids, salts and corrosive substances which cause premature aging. Moreover, thick layers of dirt and contamination absorb more moisture which increases the effects of corrosion on the protective layers.

The cleaning frequency depends on the following factors:

- The level of contamination depends on what is being grown.
- Type of product, or usage between the crops or, e.g. usage only on concrete tracks.
- Exposure to chemical fluids (spraying equipment).
- Exposure to chemical vapours or mists (treating the air space in the greenhouses).
- Exposure to sunlight and UV rays.
- Humidity in the air and condensation.

The above results in a load factor that depends on the type of usage, and where applicable, the following cleaning schedule should be followed.

When to clean:

- | | |
|--|------------------------------|
| • Plant and product residues. | daily |
| • Earth and sand | 2x weekly |
| • Glass, string, plastic, elastic, clips, wire hooks, etc. | 2x weekly |
| • Exposure to chemicals | immediately after use |
| • Dullness or contamination on the top layer | periodically after detection |

How to clean:

- Remove dirt or contamination on the top layer using a soft brush or cloth, or a compressed air line (<6 bar).
- Chemical contamination should be removed using a coarse sponge or soft cloth drenched in tap water.
- Clean a dull or contaminated top layer using a neutral cleaning agent with a pH value between 5 and 8 (check the label on the packaging) and a sponge or soft cloth.
- **Tip**, when a cleaning agent is used for the first time it is recommended to initially test the agent on a small section of the top layer before continuing.

What you must not do:



- Never clean the powder coating using an abrasive or burnishing cleaning agent.
- Never use cleaning equipment with an abrasive surface (steel wool, abrasive sponges, etc).
- Pressing down, polishing or scrubbing, etc, is not permitted.
- Never use organic cleaning solutions for cleaning or maintaining the powder coating.
- Pouring over water, using a water hose or high pressure cleaner can cause damage.

After cleaning:

- Ensure that the cleaned surfaces are properly dry and temporarily remove overlapping protective covers and screens.
- All pivots and hinges, etc, that have been in contact with cleaning agents should be lubricated according to the recommendations given in the maintenance schedule in the user manual.
- Treat any damaged areas on the powder coating layer with lacquer or paint.

Please note:

The above are only **recommendations** and therefore responsibility for the proper cleaning remains with the person carrying it out. Please contact the manufacturer if you have any queries regarding the appropriate cleaning products to be used.