

AGITATOR 1.1m: TECHNICAL FEATURES

AG 011

CODE

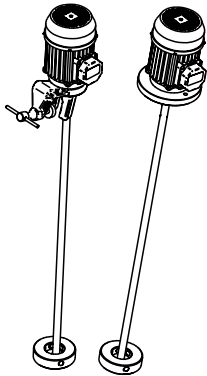

70 - J B - B 1100 - T09 P

Material	P: PP,A ISI304
Turbine	T09: Ø 90
Length	1100 mm
Ø Shaft	B: Ø 20 mm
Support	B: Flange P: Clamp
Motor	J: 230V 3ph 50/60Hz 185W T63 K: 230V 1ph 50Hz 185W T63 U: 115V 1ph 60Hz 222W T63 V: 230V 1ph 60Hz 222W T63 D: 12VDC 130W T71

MODELS

	CODE	Motor			Dimensions						Agitation			
		V	Watts	rpm	L	Ø T	Ø Dmax	Volume	Flow					
					mm	in	mm	in	m	in	m ³	gal	m ³ /h	gpm
Flange	3ph 50Hz 70-JB-B1100-T09P	230	185	1400	1100	43	90	3.5	0.8	31	0.6	160	1.6	7
	3ph 60Hz 70-JB-B1100-T09P	230	222	1650	1100	43	90	3.5	0.9	35	0.8	210	2	8.8
	1ph 50Hz 70-KB-B1100-T09P	230	185	1400	1100	43	90	3.5	0.8	31	0.6	160	1.6	7
	1ph 60Hz 70-UB-B1100-T09P	115	222	1650	1100	43	90	3.5	0.9	35	0.8	210	2	8.8
	70-VB-B1100-T09P	230	222	1650	1100	43	90	3.5	0.9	35	0.8	210	2	8.8
Clamp	12VDC 70-DB-B1100-T09P	12	130	1400	1100	43	90	3.5	0.8	31	0.6	210	1.6	7
	12VDC 70-DB-P1100-T09P	12	130	1400	1100	43	90	3.5	0.8	31	0.6	210	1.6	7

DIMENSIONS

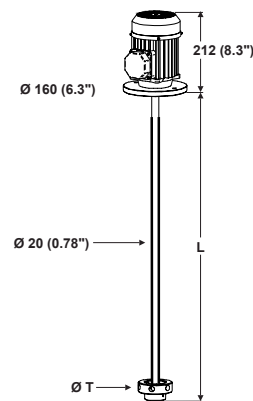
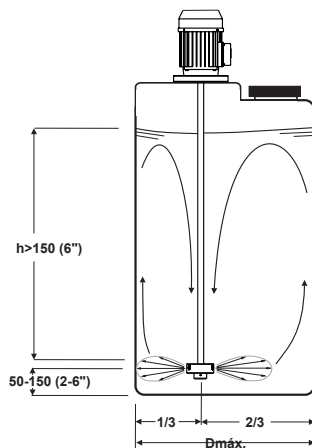

MATERIALS

Turbine	PP
Shaft	AISI 304 / PE
Screws	AISI 304
Flange	PP

MOTOR

	3ph	12VDC
Power	185W (0,25Hp)	130W(0,17Hp)
Voltage	230V - 430V	12V DC
Current	1.5A - 0,9A	15A
Frequency	50Hz - 60Hz	
r.p.m	1400 - 1650	1400
Protection	IP-55	IP-20
Class	F	B
Frame	T63 B14	T71 B14