

AGITATOR 1.5-2.0m: TECHNICAL FEATURES

AG 014

CODE

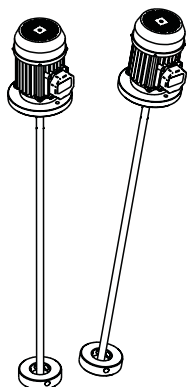

70 - S B - A 1800 - T18 P

Material	P: PP, AISI304
Turbine	T18: Ø 180 (50Hz) T15: Ø 150 (60Hz)
Length	2000 mm 1800 mm 1500 mm
Ø Shaft	A: Ø 25 mm
Support	B: Flange
Motor	S: 3ph 550w 1000rpm

MODELS

	Code	Motor		Dimensions						Agitation				
		Watts	rpm	L	Ø T	Ø Dmax	Volume	Flow						
				mm	in	mm	in	m	in	m ³	gal	m ³ /h	gpm	
Flange	70-SB-A2000-T18P			2000	78.7					7.0	1800			
	3ph 50Hz	70-SB-A1800-T18P	550	950	1800	70.9	180	7.1	1.9	75	6.0	1600	8.3	36.5
		70-SB-A1500-T18P			1500	59					5.0	1300		
Flange	70-SB-A2000-T15P			2000	78.7					5.0	1200			
	3ph 60Hz	70-SB-A2000-T15P	660	1100	1800	70.9	150	5.9	1.6	63	4.0	1100	8.0	35.2
		70-SB-A1500-T15P			1500	59					3.0	950		

DIMENSIONS

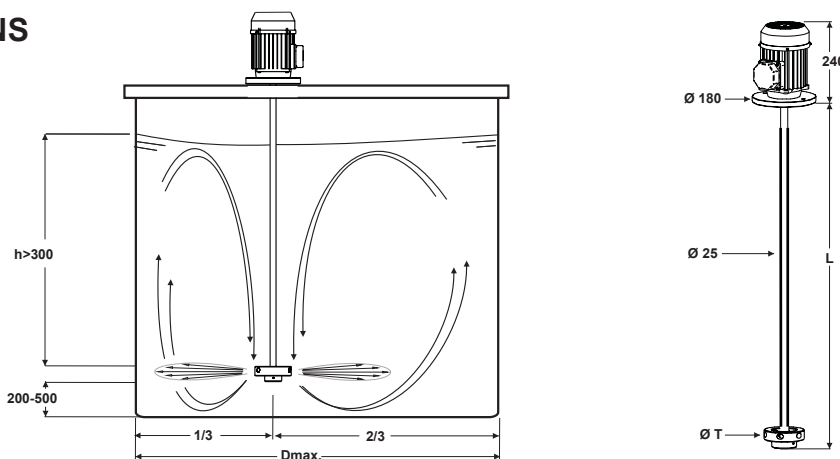

MATERIALS

Turbine	PP
Shaft	AISI 304 / PE
Screws	AISI 304
Flange	PP

MOTOR

	3ph
Power	550W (0,75Hp)
Voltage	230V - 430V
Current	3.0A - 1,8A
Frequency	50Hz - 60Hz
r.p.m	950 - 1100
Protection	IP-55
Class	F
Frame	T80 B14