

WARNING

PERSONAL INJURY MAY RESULT IF THE FOLLOWING SAFETY PRECAUTIONS ARE NOT OBSERVED.

1. BE SURE THE AREA SURROUNDING MACHINE IS FREE OF ALL HAZARDS SUCH AS FIRE, WATER, OIL, RUBBISH OR ANYTHING THAT CAN CAUSE INJURY.
2. DO NOT OPERATE MACHINE IN AN EXPLOSIVE AREA OR UNDER WET CONDITIONS. THE MACHINE IS NOT AN EXPLOSION-PROOF TYPE NOR WATER-PROOF.
3. DO NOT OPERATE MACHINE BEFORE READING INSTRUCTION MANUAL.
4. DO NOT OPERATE MACHINE ON VOLTAGES OTHER THAN SPECIFIED FOR THE MACHINE.
5. BE SURE MACHINE IS CONNECTED TO BUILDING ELECTRICAL SAFETY GROUND (EARTH).
6. BE SURE POWER (AND AIR SUPPLY) IS OFF BEFORE PERFORMING MACHINE MAINTENANCE, PARTS REPLACEMENT, ADJUSTMENTS OR CLEANING.
7. DO NOT OPERATE MACHINE WITH GUARDS AND COVERS REMOVED.
8. DO NOT TOUCH KNIFE, NEEDLE, PULLEY, BELT AND MOVING PARTS WHEN MACHINE IS IN OPERATION.
9. BE SURE MACHINE IS PLACED ON A SMOOTH (LEVEL) SURFACE WHEN PERFORMING MAINTENANCE, PARTS REPLACEMENT, ADJUSTMENTS, CLEANING OR STORAGE.
10. BE SURE THE MATERIAL TO BE SEWN OR CLOSED COMPLIES WITH THE MACHINE SPECIFICATIONS.
11. DO NOT USE SPARE PARTS OTHER THAN "NLI" GENUINE PARTS.

PRECAUCIÓN

NO SEGUIR LAS INSTRUCCIONES QUE SE DETALLA PUEDE RESULTAR PERJUDICIAL PARA SU SALUD.

1. ASEGURARSE QUE ALREDEDOR DE LA MAQUINA. NO HAYA NINGUN ELEMENTO COMO FUEGO, AGUA, ACEITE U OTROS QUE PUEDAN OCASIONAR ALGUN ACCIDENTE.
2. NO USAR LA MAQUINA EN NINGUN AREA QUE TENGA RIESGO DE EXPLOSION O BAJO CONDICIONES DE HUMEDAD. LA MAQUINA NO ES SOLO EL TIPO A PRUEBA DE EXPLOSION, SINO EL TIPO A PRUEBA DE AGUA.
3. USAR LA MAQUINA, DESPUÉS DE HABER LEIDO CON DETENIMIENTO EL MANUAL DE INSTRUCCIONES.
4. NO USAR LA MAQUINARIA CON VOLTAJES DIFERENTES A LOS ESPECIFICADOS PARA LA MISMA.
5. ASEGURARSE DE QUE LA MAQUINA ESTA CONECTADA A UNA ZONA ELECTRICA DE SEGURIDAD CON TOMA DE TIERRA.
6. ASEGURARSE DE DESCONECTAR LA MAQUINA ANTES DE PROCEDER A SU MANTENIMIENTO, SUSTITUCION DE PIEZAS, AJUSTE Y LIMPIEZA DELA MAQUINA.
7. NO USAR LA MAQUINA CON OBJETOS EXTRAÑOS, NI CUANDO TENGA UNA TAPADERA ABIERTA.
8. NO TOCAR LAS CUCHILLAS, AGUJAS, POLEAS, CORREAS Y PARTES MOVILES CUANDO LA MAQUINA ESTA EN FUNCIONAMIENTO.
9. ASEGURARSE DE QUE LA MAQUINA ESTA EN UN LUGAR APROPIADO PARA PROCEDER AL MANTENIMIENTO, RECAMBIO DE PIEZAS, AJUSTES, LIMPIEZA O ALMACENAJE.
10. ASEGURARSE DE QUE EL MATERIAL A COSER ENTRA DENTRO DE LAS ESPECIFICACIONES DE LA MAQUINA.
11. NO USAR NINGUNA PIEZA DE RECAMBIO QUE NO SEA "NLI" .

ACHTUNG

VERLETZUNGSGEFAHR BEI NICHT BEACHTEN DER FOLGENDEN VORSICHTSMASSNAHMEN !

1. DIE UMGEBUNG DER MASCHINE MUSS FREI SEIN VON GEFAHREN QUELLEN WIE FEUER, WASSER, ÖL, ABFALL UND ALLEN ANDEREN DINGEN, DIE VERLETZUNGEN VERURSACHEN KÖNNEN.
2. BENÜTZEN SIE DIE MASCHINE NICHT IN DER UMGEBUNG VON EXPLOSIVEN ODER WASSER. DIE MASCHINE IST NICHT GEGEN EXPLOSIONEN ODER WASSER GESCHÜTZT.
3. VOR DEM BEDIENEN DER MASCHINE ESRT BEDIENUNGSANLEITUNG LESEN.
4. DIE MASCHINE NUR AN ZUGELASSENE NETZSPANNUNG ANSCHLIESSEN.
5. DIE MASCHINE MUSS GEERDET SEIN.
6. DIE MASCHINE MUSS VON NETZSPANNUNG (UND LUFTVERSORGUNG) GETRENNT WERDEN, BEVOR WARTUNGSARBEITEN, JUSTAGEN UND REINIGUNG DURCHFÜHRT WERDEN KÖNNEN.
7. DIE MASCHINE DARF NICHT OHNE SCHUTZHAUBEN UND ABDECKUNGEN BETRIEBEN WERDEN.
8. MESSER, NADEL, RIEMENSCHLEIBE, RIEMEN UND ALLE BEWEGLICHEN TEILE NICHT BERÜHREN WENN DIE MASCHINE LÄUFT.
9. DIE MASCHINE SOLLTE AUCH FÜR WARTUNG, JUSTAGE, REINIGUNG ODER LAGERUNG AUF SAUBEREM UND EBENEM UNTERGRUND STEHEN.
10. DAS ZU VERWENDEnde MATERIAL MUSS DEN MASCHINENANGABEN ENTSPRECHEN.
11. NUR ORIGINAL "NLI" ERSATZTEILE VERWENDEN.

AVERTISSEMENT

ATTENTION À CE QU' EN CAS DE NE PAS OBSERVER LES ARTICLES DE SÉCURITÉ CI-DESSOUS, CA PEUT PROVOQUER UN ACCIDENT.

1. VÉRIFIEZ S' IL N'Y A PAS, AUTOUR DE LA MACHINE, DE TELLE CHOSE QUI PEUT PROVOQUER UN ACCIDENT COMME LE FEU, DE L'EAU, DE L'HUILE OU DE LA MATIÈRE COMBUSTIBLE.
2. CETTE MACHINE N'EST NI INEXPLOSIBILISÉE NI IMPERMÉABILISÉE, DONC NEL'UTILISEZ PAS À UNE PLACE QUI COMPORTE UN RISQUE D'EXPLOSION OU QUI A UNE POSSIBILITE DE SE MOUILLER.
3. NE MANQUEZ PAS DE LIRE LE MANUEL D'INSTRUCTION AVANT DE METTRE LA MACHINE EN MARCHE.
4. NE METTEZ PAS LA MACHINE EN MARCHE AVEC UN AUTRE VOLTAGE QUE CELUI D'INDIQUÉ.
5. VÉRIFIEZ SI LA PRISES DE TERRE EST CORRECTEMENT CONNECTÉE.
6. NE MANQUEZ PAS DE COUPER LE COURANT (ET LE GAZ COPRIMÉ) AVANT L'ENTRETIEN, LE CHANGEMENT DE PIÈCE, LA MISE AU POINT OU LE NETTOYAGE DE LA MACHINE.
7. NE METTEZ PAS LA MACHINE EN MARCHE AVEC LE COUVERCLE OU LA COUVERTURE ENLEVÉ(E).
8. NE TOUCHEZ PAS TELLES PARTIES QUI BOUGENT COMME LE COUPOIR, L'AIGUILLE, LA POULIE, LA COURROIE ETC. PENDANT LA MISE EN MARCHE DE LA MACHINE.
9. LORS DE L'ENTRETIEN, LE CHANGEMENT DE PIÈCE, LA MISE AU POINT OU LE MAINTENANCE DE LA MACHINE, METTEZ-LA À UNE PLACE PLATE.
10. VÉRIFIEZ SI VOTRE MATIÈRE À COUDRE S'ADAPTE À LA SPÉCIFICATION DE LA MACHINE.
11. N'EMPLOYEZ PAS D'AUTRE PIÈCE QUE CELLE DE CONVENABLE DE "NLI" .

CONTENTS

1.SPECIFICATIONS	2
2.THE POINTS BEFORE OPERATION	2
3.PREPARATION FOR START	3
1.Oiling	3
2.Needle Setting	3
3.Threading	3
4.START	4
5.AJUSTMENTS	5
1.Thread Tension	5
2.Position of Needle and Looper	5
3.Position of Feed Dog	5
4.Pressure of Presser Foot	5
5.Presser Foot Lifter	5
6.How to use Hook	5
6.REPLACING PARTS	6
7.LUBRICATOR	7
1.Operation	7
2.Maintenance	7
3.Troubleshooting	7
8.MAINTENANCE	8
9.ORDERING PARTS	9
NUMERICAL INDEX OF PARTS	26,27
LIST OF SCREW,NUT & WASHER	28

I. SPECIFICATIONS

- This Bag Closing Machine is designed for use in the light industries.

TECHNICAL DETAILS

Speed (sec./bag).....	5-6
Seam.....	Single Thread Chain Stitch
Stitch Range (mm.).....	8.5 (fixed)
Revolution (rpm.).....	1700~1900
Needle.....	DN×1 #25
Thread (vinylon,synthetic or cotton).....	20/6
Bag Material To Be Closed.....	Kraft Paper, PP/PE Woven Cloth, Cotton Hessian, Jute
Drive Motor.....	90W or 65W
Power Supply.....	110~120, 220 or 230~240V, (A.C.) 12V, 24V.,(D.C.) 50-60Hz, Single Phase
Net Weight (kg).....	6kgs Including Thread Cone.
Machine Dimension (mm.).....	361(L)×246(W)×321(H)
Packing Dimension (cft.).....	2.5

■ STANDARD ACCESSORIES

1.Needles DN×1 #25.....	5 pcs.
2.Thread Vinylon 20/6.....	1 roll
3.Screw Driver.....	1 pce.
4.Needle Bar Spanner.....	1 pce.
5.Oil.....	1 can

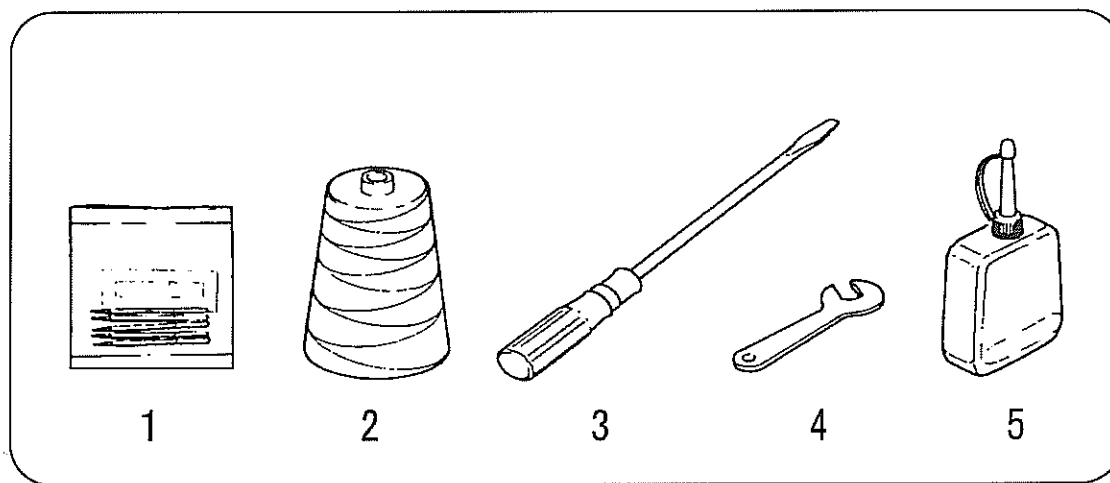

2. THE POINTS BEFORE OPERATION

- Oil the area through which thread passes, the tension disc, the thread guide, looper, etc.
(Note:An anticorrosive agent is applied to the machines at the factory, in order to prevent rusting.
It is necessary to use oil to remove this agent. or it may prevent the thread from passing smoothly.)
- Confirm that the machine has been threaded as per Fig.5 in the manual.
- Confirm that the machine has been lubricated as per Fig.1 in the manual.

3. PREPARATION FOR START

1.Oiling (Fig.1)

Oiling is imperative to keep the machine in good operating condition. Pour oil in the reservoir (capacity 45 cc). To begin the flow of oil to the machine, push the button of the lubricator ten times continuously before starting the machine. This should dispense enough oil for an average running of four hours under normal operating conditions. Do not run the machine without oil as it could causes a machine failure or break down.

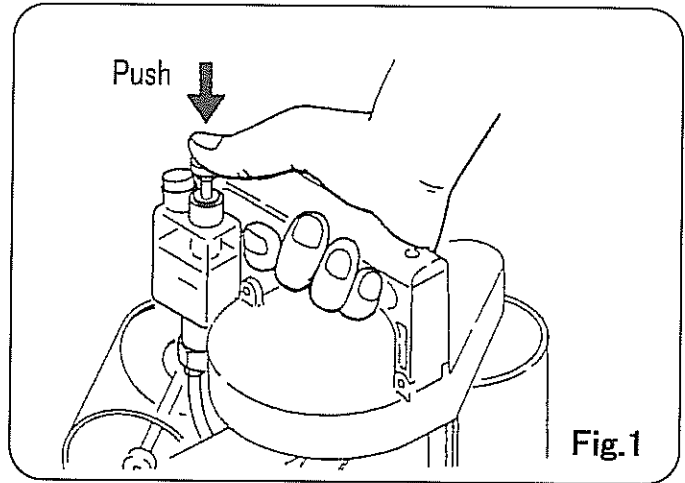

Fig.1

2.Needle Setting (Fig.2,3,4)

Turn the pulley until Needle Bar reaches its highest position. Loosen Needle Bar Clamping Nut, and set Needle in the Bar as deep as it will go.

Be sure to set a Needle with its concave part facing correctly toward the Loper. Fix Clamping Nut tightly, otherwise Needle may come loose during operation and break.

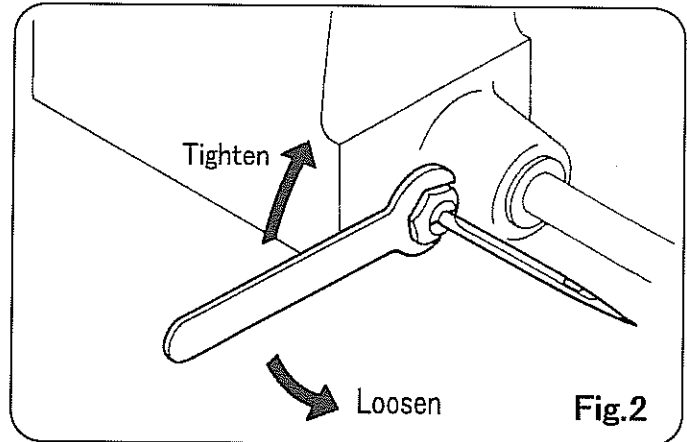

Fig.2

3.Threading (Fig.5)

The machine is delivered being threaded to show you proper threading of the machine, which is shown in Fig.5, for identification. Follow the guide numbers 1 to 7 of Fig.5.

- | | |
|------------------|----------------|
| ①,②Thread Eyelet | ⑤Needle Bar |
| ③Tension Disc | ⑥Thread Eyelet |
| ④Thread Eyelet | ⑦Needle |

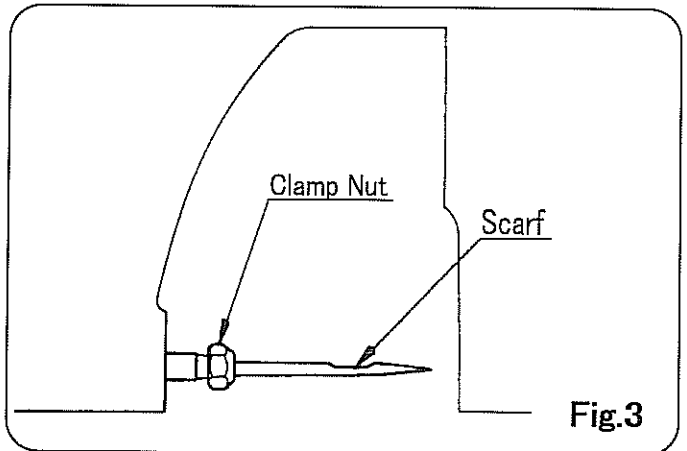

Fig.3

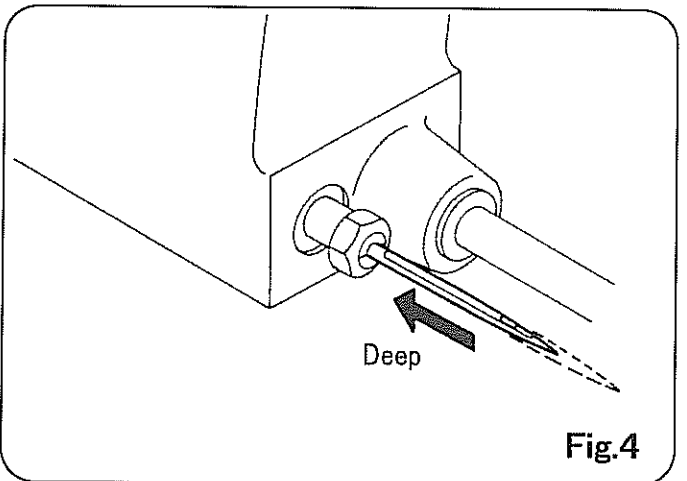

Fig.4

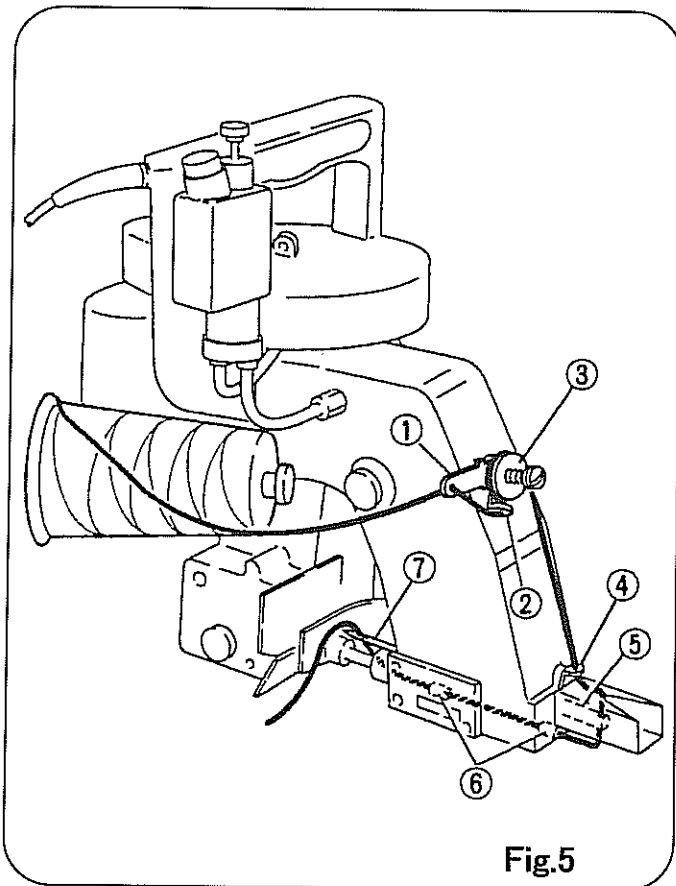

Fig.5

4. START

Before starting, make sure that the supply voltage accords with the specification of the motor.

Hold the machine in your right hand and place your index finger on the switch button on the handle.(Fig.6)

Hold the bag in your left hand lightly and insert the bag mouth between Feed Dog and Presser Foot.(Fig.7)

Run the machine while keeping the bag straight.

Never pull or pull back the bag.

After closing, the thread is cut by the built-in nibbler type cutter.

When cutting the thread, leave at least 3 cm long extended tail to prevent the unwilling loosening of the seam.(Fig.9)

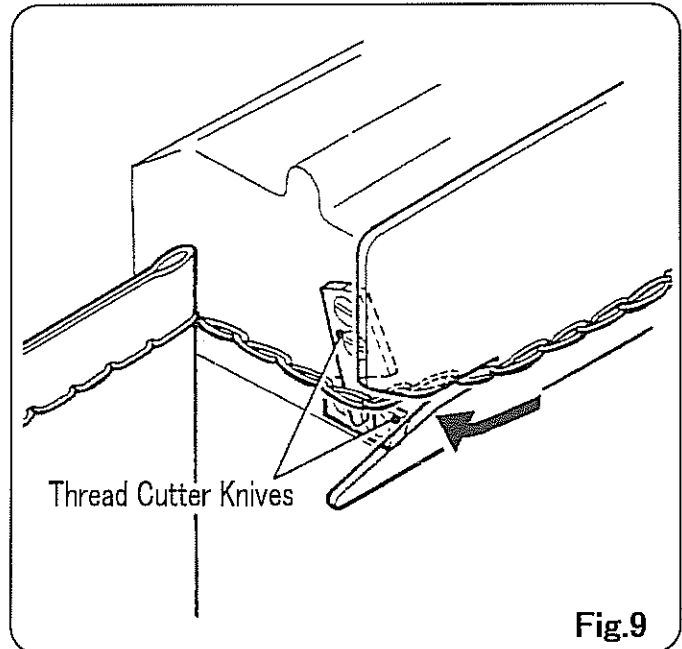
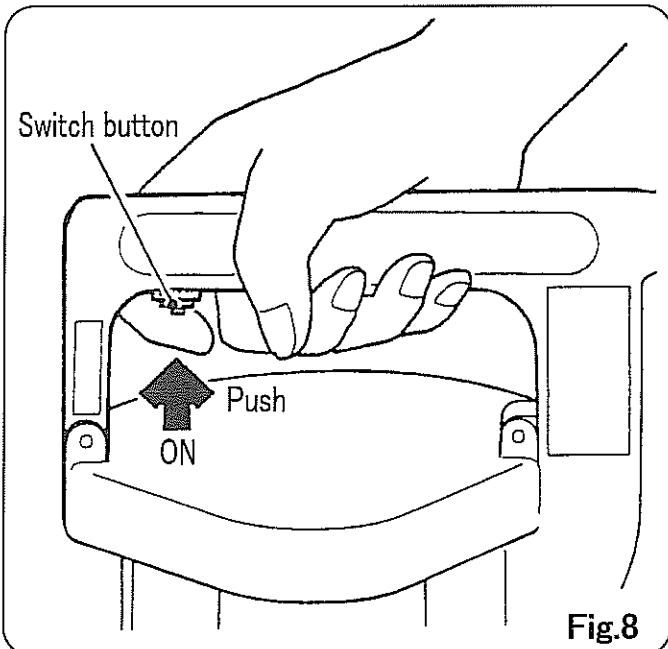
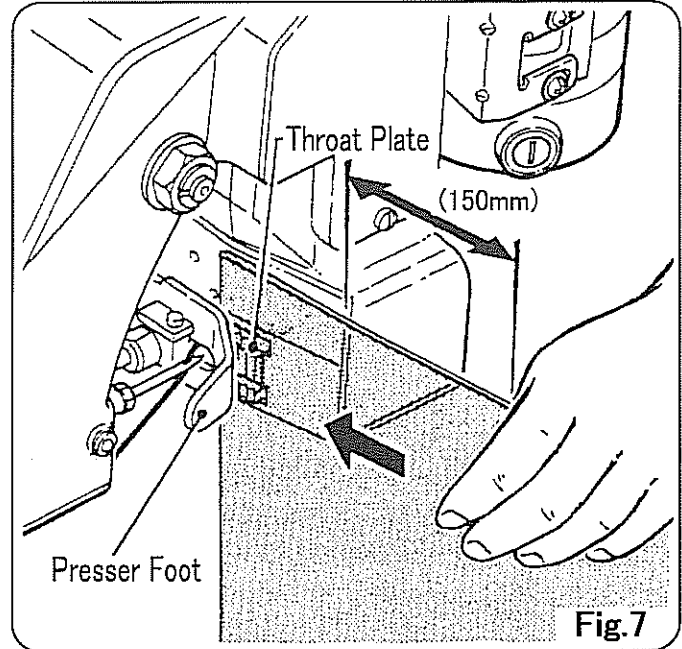
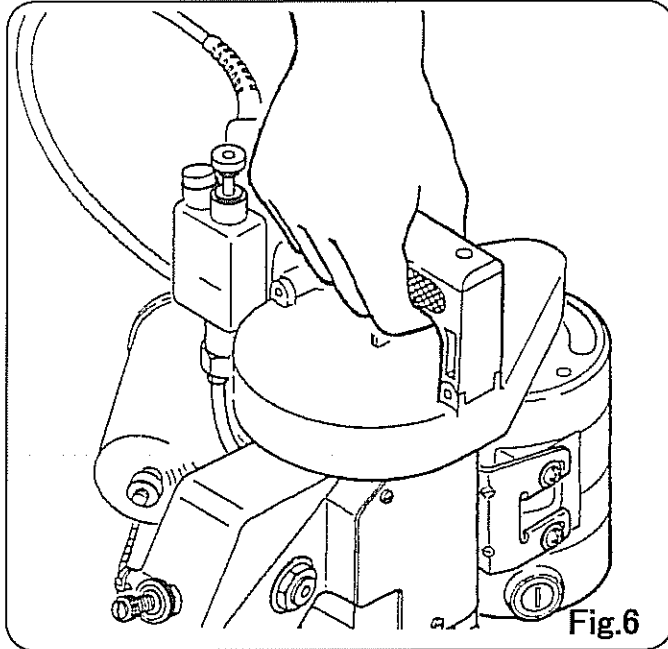

Run the machine with empty bags and make sure you are well versed in its operation before entering into actual operation.

3. ADJUSTMENTS

Important!

When adjusting the machine or replacing parts, always disconnect the Electric Cord from the power source.

This is important in view of safety to the operator and adjuster.

1. Thread Tension (Fig.10)

The thread tension spring is preset at the factory to sew PP woven cloth bags. If some adjustment is needed, first loosen screw (A) (9/64S40054) and adjust the thread tension nut (B) (245092) as per Fig.10. When the adjustment is finished, retighten screw to lock the thread tension nut.

If this is not done, the stitch will not remain uniform.

2. Position of Needle and Loper (Fig.11)

Looper must pass the concave part of Needle with clearance of 0.1 mm as shown in Fig.11. Adjustment of the clearance can be done after loosening the screw of Loper Rocker.

3. Position of Feed Dog (Fig.12)

When installing a new feed dog ensure that it is positioned correctly onto the feed dog carrier block and lightly tighten the fixing screw. Check that the feed dog teeth are 2.8mm above the throat plate when the feed dog is in the highest position before final tightening of the fixing screw.

4. Pressure of Presser Foot

When to adjust the pressure of Presser Foot, take out Needle Bar Guard and loosen Screw of Presser Bar Connection. Move up Presser Bar to increase the pressure and down to decrease. After the adjustment, tighten the Screw firmly.

5. Pressure Foot Lifter

The Presser Foot Lifter is used to lift the Presser Foot and pull out a bag from under the Presser Foot in case of a problem such as bag or thread jamming.

6. How to use Hook (Part No.241151)

The Hook on the Pulley Cover is used to install a Shoulder Belt or a Hanger.

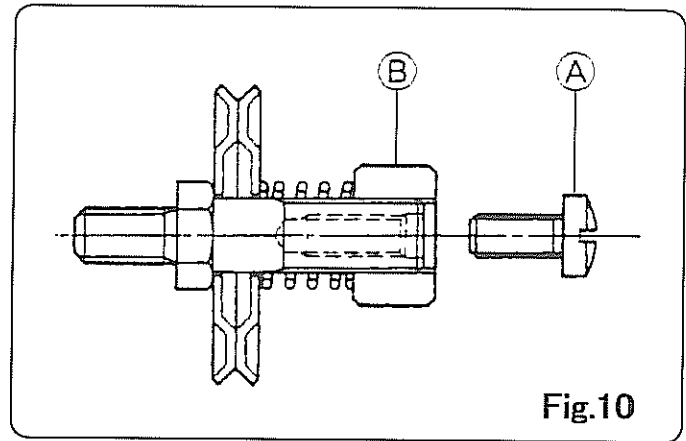

Fig.10

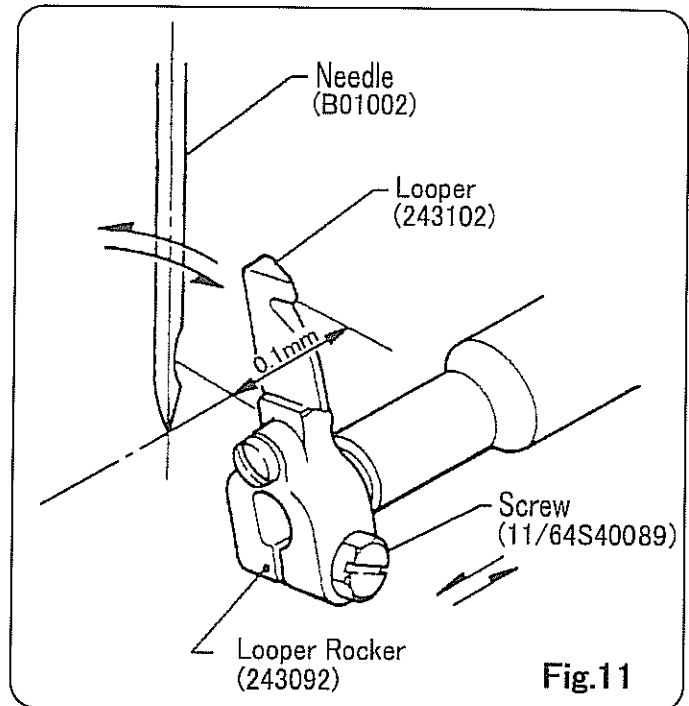

Fig.11

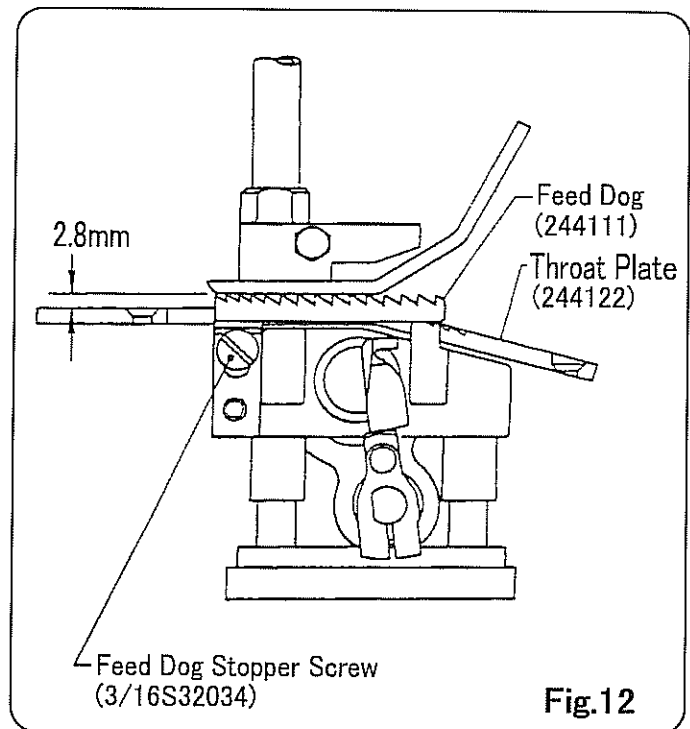

Fig.12

6. REPLACING PARTS

For replacement or adjustment of Ball Rod, refer to Fig.13. Take out Screw ① and disconnect Rod End ② from Needle Bar Lever ③. After loosening the Nut ④, adjust the clearance between Connecting Rod ⑤ and Rod End ②, so that Needle Bar moves in the center of the clearance between the upper and lower Presser Bar Bushings. (Needle Bar stroke is 37 mm).

To fix Eccentric Cam ⑦ on Main Shaft ⑧, tighten the Screw ⑨ and ⑨' on Main Shaft ⑧ (Eccentric Cam ⑦ should contact Spacer ⑩ slightly.).

The position of Needle is adjusted so that the distance between the point of Needle (at its highest position) and Throat Plate is 13 mm, after loosening screw on Needle Bar Connection Assembly ⑥ in Fig.13.

- ① Screw 11/64S40084
- ② Rod End 6A04001
- ③ Needle Bar Lever 242051A
- ④ Nut 1N8
- ⑤ Connecting Rod Assembly 242011A
- ⑥ Needle Bar Connection Assembly 242101A
- ⑦ Eccentric Cam (part of Connecting Rod Assembly) 242011
- ⑧ Main Shaft 241102
- ⑨ ⑨' Screw 11/64S40001
- ⑩ Spacer 241161

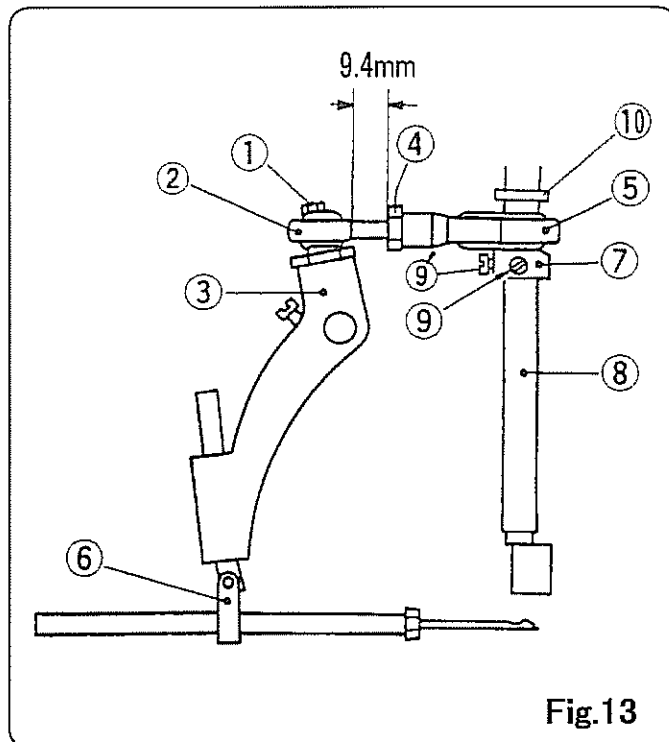

Fig.13

Adjust Looper Drive Cam ③ When necessary as follows: (Refer to Fig.14.).

- a) Apply the Screws ② and ②' on the taper of Main Shaft ①.
- b) Adjust Arm (B) ④, so that Looper Drive Cam ③ and Arm (A) ⑤ move smoothly. After adjusting, fix the Screw ⑥ tightly.
- c) The clearance between Looper Drive Cam ③ and Arm ⑤ is effected by Spring ⑦. Loosen Screw ⑨ and turn Spring Supporter ⑧ to adjust the pressure of Spring ⑦. After adjusting, tighten the Screw ⑨ to fasten Spring Supporter ⑧.

- ① Main Shaft 241102
- ② ②' Screw 15/64S28524
- ③ Looper Drive Cam 243012
- ④ Looper Rocker Shaft Arm (B) 243081
- ⑤ Looper Rocker Shaft Arm (A) 243071
- ⑥ Screw for Looper Rocker Shaft Arm (B) 11/64S40009
- ⑦ Spring 243131
- ⑧ Spring Supporter 243121
- ⑨ Screw for Spring Supporter Block 11/64S40003

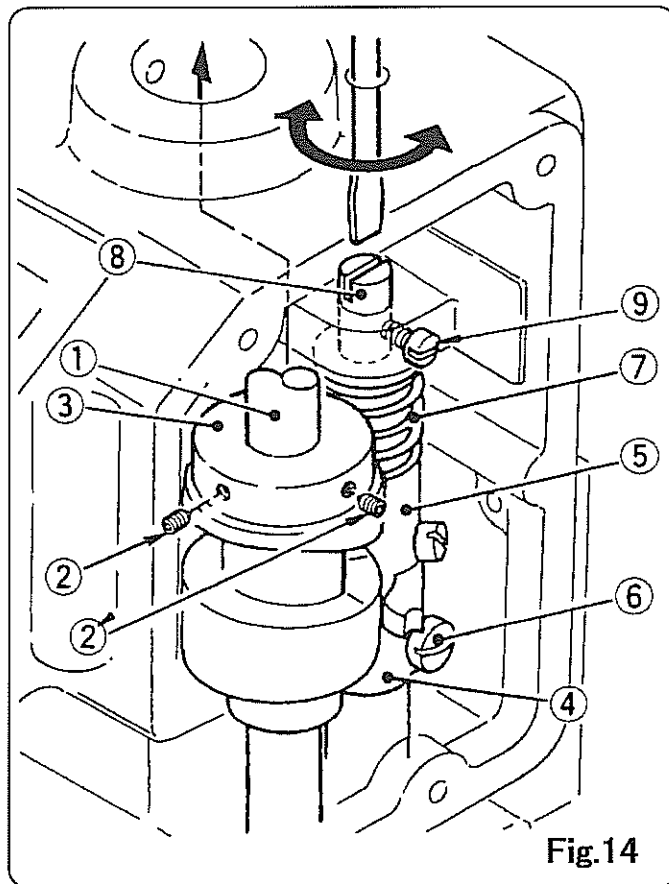

Fig.14

7. LUBRICATOR

1. Operation

The lubricator comprises a pump and a reservoir. The reservoir holds max 45 cc of oil. (Effective oil volume is 28 cc.)

Use mineral oil 22-32 cSt at 40°C (Eg. Tellus oil #32).

To operate the lubricator.

1. First unscrew the reservoir cap by half a turn.*
2. Push the button to its lowest position (stroke:12mm)
3. When released, the button will automatically return to its original position.
4. Lastly, tighten the cap to prevent oil leak during operation.

* Repeated working on the button without first loosening the cap may produce negative pressure in the reservoir, and the dust in the atmosphere may be easily introduced in it when the cap is loosened.

2. Maintenance

1. Keep off dust or foreign matter when to fill oil (They may cause jamming of the piston and the check valve).
 2. Rate of discharge is fixed and not adjustable (0.08cc per push).
 3. At high temperatures, grease may run along points (A). This is normal, grease being used when the lubricator was assembled in our plant.
 4. Reservoir is made of high density polyethylene. Keep off fire and refrain from using organic, benzene, or xylene chemicals for cleaning.
- Check periodically for correct working of the pump. (Repeat oil feed and look at the oil through the discharge pipe.)

3. Troubleshooting

Trouble	Cause	Remedy
Oil not fed.	Low Oil level.	Fill oil.
Full stroke movement not obtainable.	Dust attached on the interior wall of the pumping chamber.	Replace lubricator.
Button will not return.	Dust accumulated, or break of spring.	Replace lubricator.
Oil leak from (A)	Wornout or displaced seal of O-Ring.	Replace lubricator.
Oil leak from (B)	Wornout or displaced seal of packing.	Replace lubricator.
Oil leak from (C)	Loose plug.	Tighten plug or Replace lubricator.

PUSH-BUTTON LUBRICATOR Model:NP-7A

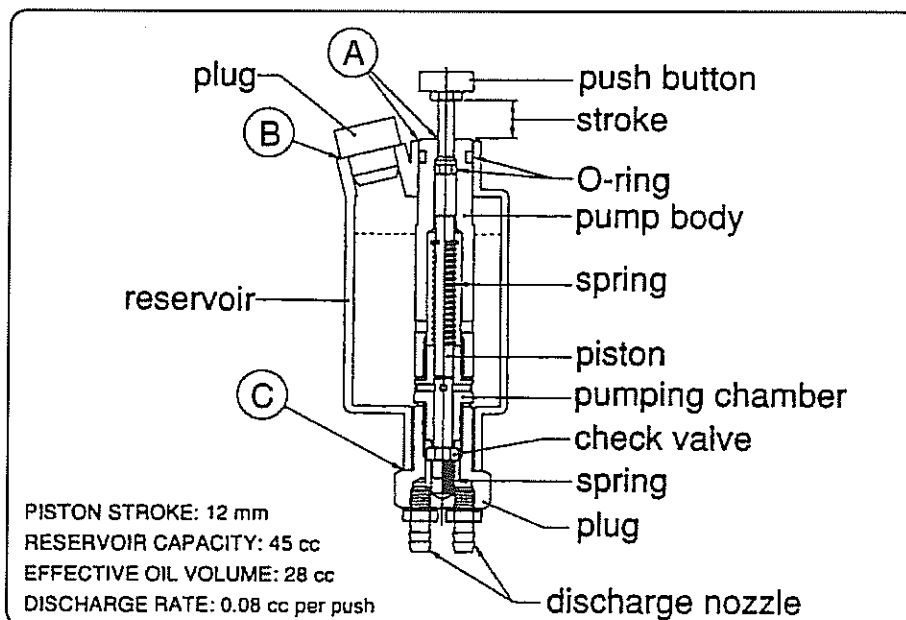

MAINTENANCE

Clean the machine at the end of the day's work, and oil the bushings, shaft, etc. that are not lubricated by a lubricator. Wipe dust and other foreign matter off the Feed Dog teeth Looper and Throat Plate eyelet where they are easily gathered.

Care should be taken to keep the machine free from dust, especially when to leave it unused for some time.

Important!

The motor body should not be opened for the maintenance.

When adjusting the machine or replacing parts, always disconnect the Electric Cord from the power source.

This is important in view of safety to the operator and adjuster.

[NOTES ON CARRYING AND STORAGE]

1. Carry the machine in a storage box.
2. After the use of the machine, remove the plug, clean the dirt, take the thread from the machine and then put it into a storage box.

We suggest you to use a soft brush to clean the rear of the machine.

3. Never store the machine under the sunlight dried or wet condition.

9. ORDERING PARTS

The parts list showing all the parts used in the machine is included in this book. Check the list, and specify parts numbers and quantities required clearly. Send your order to the nearest agent, distributor or one of our branch offices.

1. Description of each part and its stamp number is described in this parts list.
Screws and nuts for parts are shown adjacent to the relevant parts. When ordering parts, describe clearly stamp number with its name of part.
 2. The parts which have no Ref. Number can not be delivered independently; always order it as an assembly.
 3. A set of assembled parts is represented by the stamp number of its main parts.
 4. The last figure on the parts stamp number advances on each improvement of the parts.
 5. Parts No. described in [] of Remarks means old parts No.
- The parts list is subject to change without prior notice.

CONTENTS

(1) THREAD TENSION AND COVER PARTS	10
(2) BUSHING, OILING AND HANDLE PARTS	12
(3) NEEDLE BAR, PRESSER BAR AND DRIVING PARTS	14
(4) LOOPER DRIVING PARTS	16
(5) FEED DRIVING AND THREAD CUTTER PARTS	18
(6) MOTOR PARTS (For Totally Enclosed Type Motor)	20
(7) SPECIAL PARTS FOR NP-7H TYPE	22
(8) CREPE TAPE BINDING AND CUTTER PARTS (Special Order Parts)	24
NUMERICAL INDEX OF PARTS	26
LIST OF SCREW, NUT & WASHER	28

(1) THREAD TENSION AND COVER PARTS

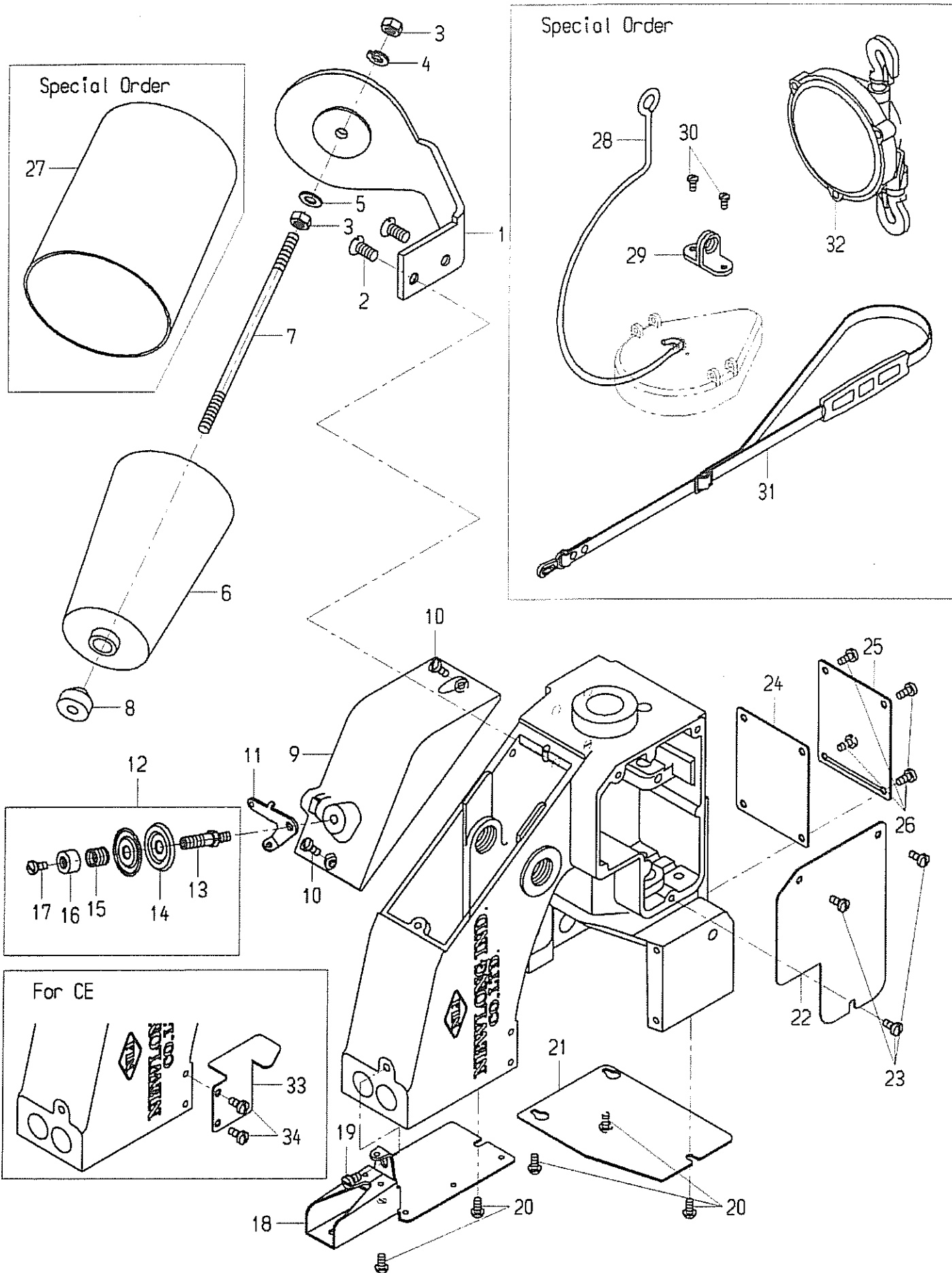

(1) THREAD TENSION AND COVER PARTS

Ref. No.	Part No.	Description	Q'ty	Remarks
1	245042	Thread Stand	1	
2	15/64S28028	Screw, for 245042	2	
3	1N6	Nut	2	
4	3W6	Spring Washer	1	
5	2W6	Washer	1	
6	K01001	Thread	1	
7	245052	Thread Cone Clamping Rod	1	
8	245201	Thread Cone Clamping Nut	1	
9	245014	Top Cover	1	
10	9/64S40005	Screw, for 245014	2	
11	245551	Thread Eyelet	1	
12	245081C	Thread Tension Assembly	1	(13~17)
13	245081	Tension Post	1	
14	065261	Tension Disc	2	
15	245101	Tension Spring	1	
16	245092	Tension Nut	1	
17	9/64S40005	Screw, for 245081C	1	
18	245033	Needle Bar Guard	1	
19	11/64S40005	Screw, for 245033	1	
20	9/64S40065	Screw, for 245033,245222	5	
21	245222	Looper Cover	1	
22	245022	Side Plate	1	
23	9/64S40005	Screw for 245022	3	
24	245481	Gasket	1	
25	245302	Inside Cover	1	
26	9/64S40005	Screw, for 245302	4	
27	245181	Thread Cone Cover	(1)	
28	245271	Hanger	(1)	
29	241151	Hook	(1)	
30	1/8S40006	Screw	(2)	
31	245171	Shoulder Belt	(1)	
32	MW-6.5	Spring Balancer	(1)	
33	245571	Guard	(1)	
34	9/64S40005	Screw, for 245571	(2)	

(2) BUSHING, OILING AND HANDLE PARTS

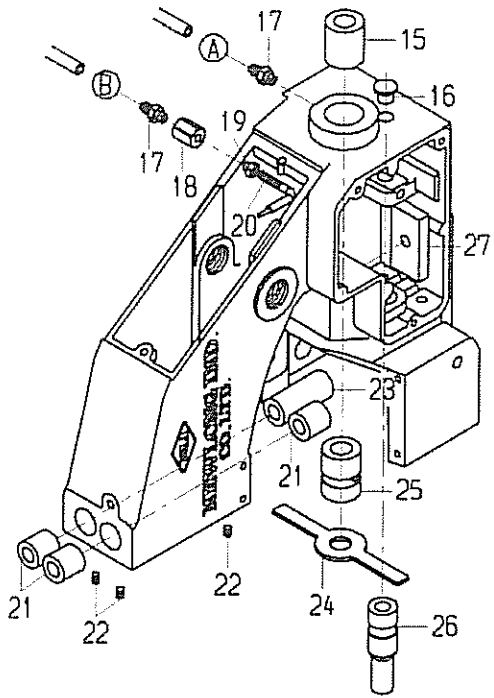

31

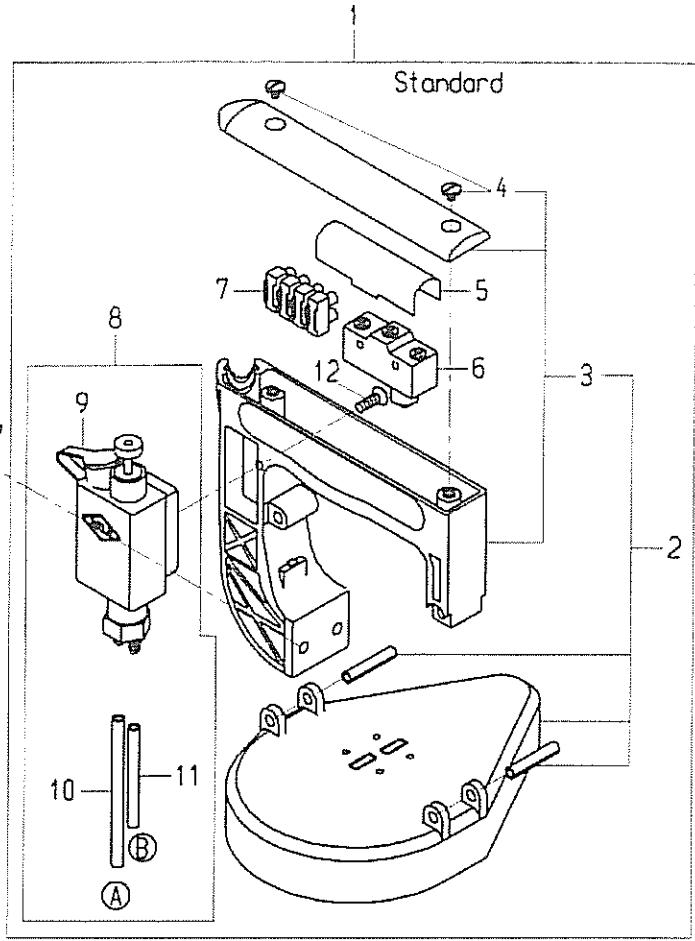
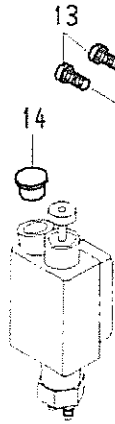

28

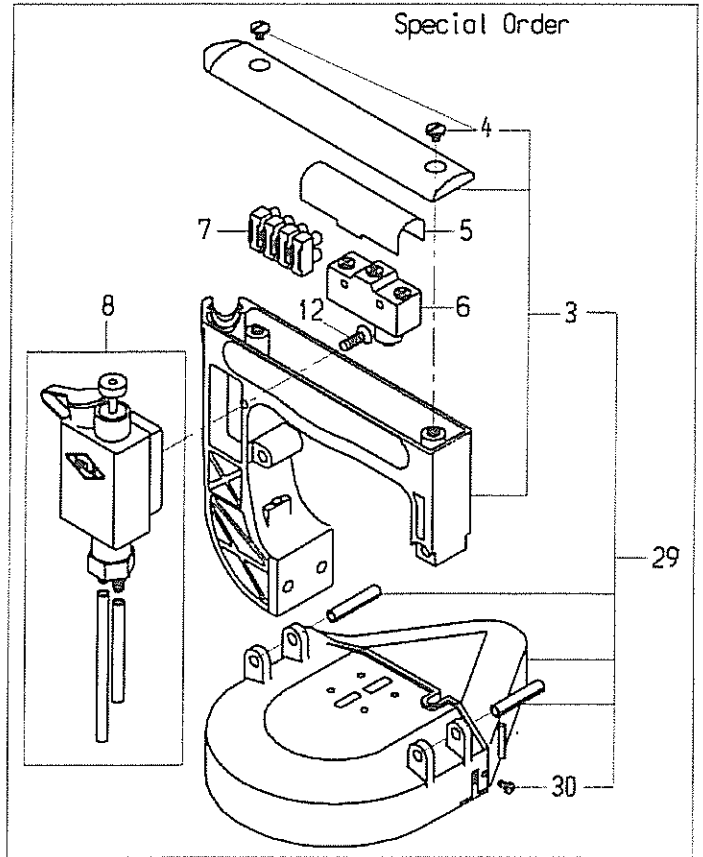
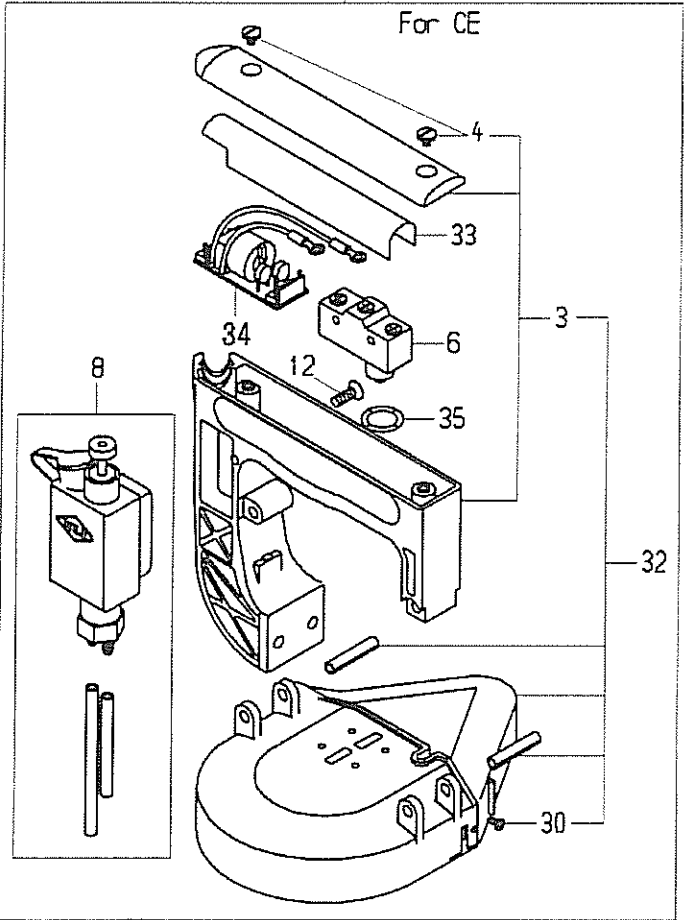

(2) BUSHING OILING AND HANDLE PARTS

Ref. No.	Part No.	Description	Q' ty	Remarks
1	241024AS	Handle Assembly	1	(2, 5-8, 12)
2	241024A	Handle Assembly	1	(3)
3	241024	Handle	1	(4)
4	9/64S40011	Screw, for 241024A	2	
5	245132	Micro Switch Cover	1	
6	C02001	Micro Switch (Z-15GK655-B)	1	
6	C02006	Micro Switch (X-10GD-B), for DC motor	1	
7	C05008	Flexible Terminal Block (ML-SK-1, 4P)	1	
8	D03003	Oiler	1	(9-11)
9	248141	Oiler Cap	1	
10	8FU2-6×90F	Oil Tube, with oil felt	1	
11	8FU2-6×60F	Oil Tube, with oil felt	1	
12	6S5×15	Screw, for D03003	1	
13	15/64S28021	Screw, for 241024A	2	
14	255351	Rubber Bushing	(1)	
15	241122	Main Shaft Bushing, rear	1	
16	065401	Rubber Bushing	1	
17	D07021	Joint (BN-5-6)	2	
18	245471	Joint	1	
19	1N4	Nut	1	
20	245461	Oil Pipe	1	
21	242212	Bushing for Presser Bar & Needle Bar, upper	3	
22	9/64S40504	Screw, for 242212	3	
23	242222	Presser Bar Bushing, lower	1	
24	245541	Oil Felt	1	
25	241111	Main Shaft Bushing, lower	1	
26	243021	Looper Rocker Shaft Bushing	1	
27	245162	Oil Felt	1	
28	241024BS	Handle Assembly (Safety type with pulley cover)	(1)	(5-8, 12, 29)
29	241024B	Handle Assembly (Safety type with pulley cover)	(1)	(3, 30)
30	9S2.6×10	Screw, for 241024B	(1)	
31	241024DS	Handle Assembly	(1)	(6, 8, 12, 32-35)
32	241024D	Handle Assembly	(1)	(3, 30)
33	245133	Micro Switch Cover	(1)	
34	C09002	Noise Filter	(1)	
35	31LP16	"O" Ring	(1)	

(3) NEEDLE BAR, PRESSER BAR AND DRIVING PARTS

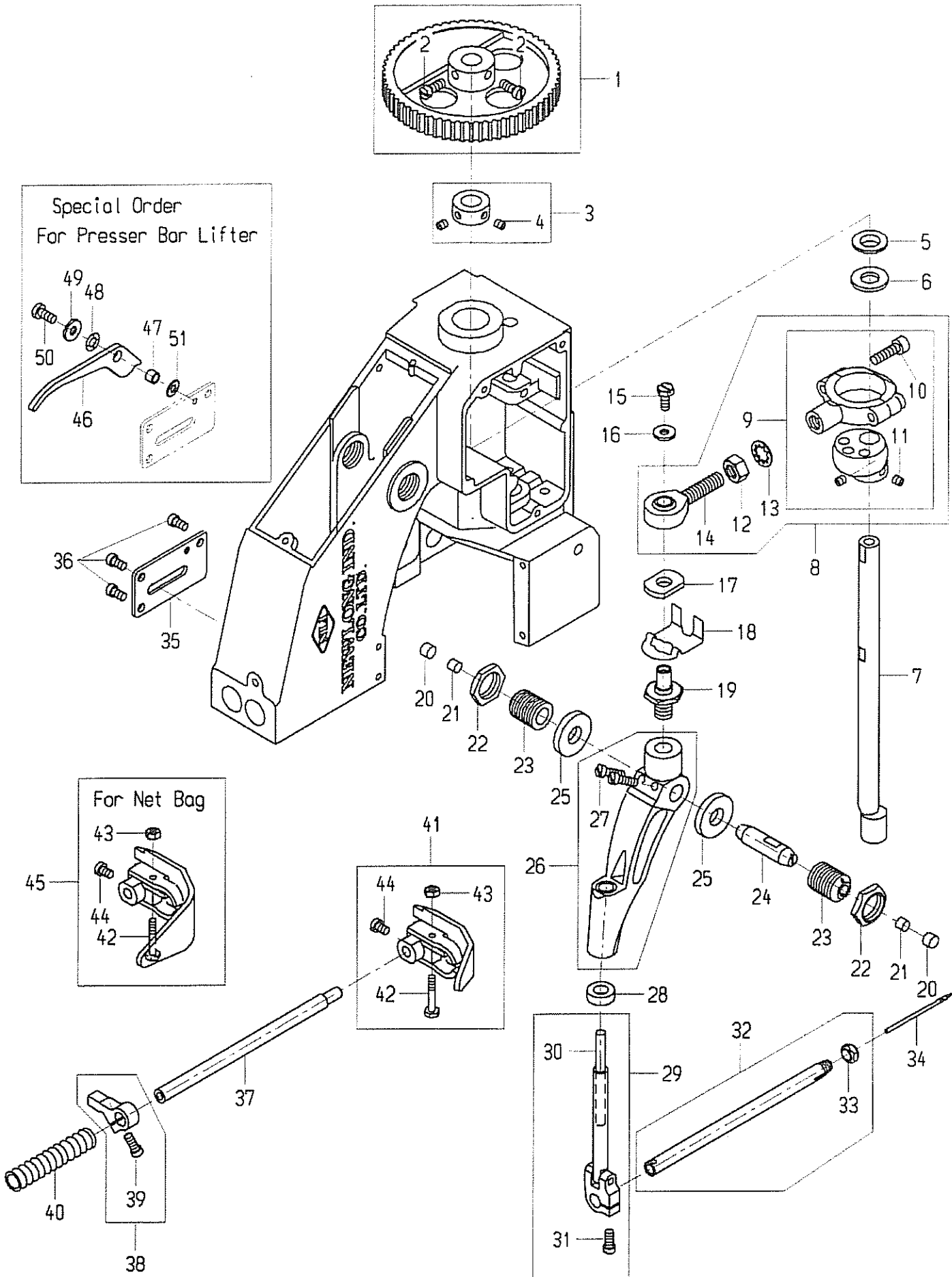

(3) NEEDLE BAR, PRESSER BAR AND DRIVING PARTS

Ref. No.	Part No.	Description	Q'ty	Remarks
1	241092	Synchro Pulley	1	(2)
2	3/16S28009	Screw, for 241092	2	
3	241131	Retaining Collar	1	(4)
4	11/64S40502	Screw, for 241131	2	
5	241161	Spacer	1	
6	205131	Oil Felt	1	
7	241102	Main Shaft	1	
8	242011A	Connecting Rod Assembly	1	(9-14)
9	242011	Connecting Rod Sub- Assembly	1	(10,11)
10	4B5 × 15	Screw, for connecting rod cap	2	
11	11/64S40001	Screw, for eccentric cam	2	
12	1N8	Nut, for 242011A	1	
13	5W8	Washer, for 242011A	1	
14	6A04001	Rod End (POS-8)	1	
15	11/64S40084	Screw, for 242031	1	
16	11/64W15103	Washer, for 242031	1	
17	245211	Oil Felt	1	
18	242041	Spring	1	
19	242031	Rod End Stud	1	
20	245491	Cap	2	
21	245411	Oil Felt	2	
22	5/8N18101	Nut, for 242081	2	
23	242081	Adjusting Stud	2	
24	242071	Needle Bar Lever Stud	1	
25	245231	Oil Felt	2	
26	242051A	Needle Bar Lever Assembly	1	(27)
27	11/64S40004	Screw, for 242051A	2	
28	245371	Oil Felt	1	
29	242101A	Needle Bar Connection Assembly	1	(30, 31)
30	205171	Oil Felt	1	
31	11/64S40003	Screw, for 242101A	1	
32	242121A	Needle Bar with Nut	1	(33)
33	242131	Needle Clamp Nut	1	
34	B01002	Needle (DN × 1#25)	1	
35	242172	Presser Foot Lifter Base	1	
36	11/64S40002	Screw, for 242172	3	
37	242201	Presser Bar	1	
38	242181	Presser Bar Connection	1	(39)
39	11/64S40003	Screw, for 242181	1	
40	242191	Presser Spring	1	
41	242231A	Presser Foot Assembly	1	(42-44)
42	9/64S40055	Screw	1	
43	9/64N40101	Nut	1	
44	11/64S40005	Screw, for 242231A, 242233A	1	
45	242233A	Presser Foot Assembly (for Net Bag)	(1)	(42-44)
46	242161	Presser Foot Lifter	(1)	
47	242271	Collar	(1)	
48	31LP6	"O" Ring	(1)	
49	11/64W15103	Washer	(1)	
50	11/64S40009	Screw, for 242161	(1)	
51	2W4	Washer	(1)	

(4) LOOPER DRIVING PARTS

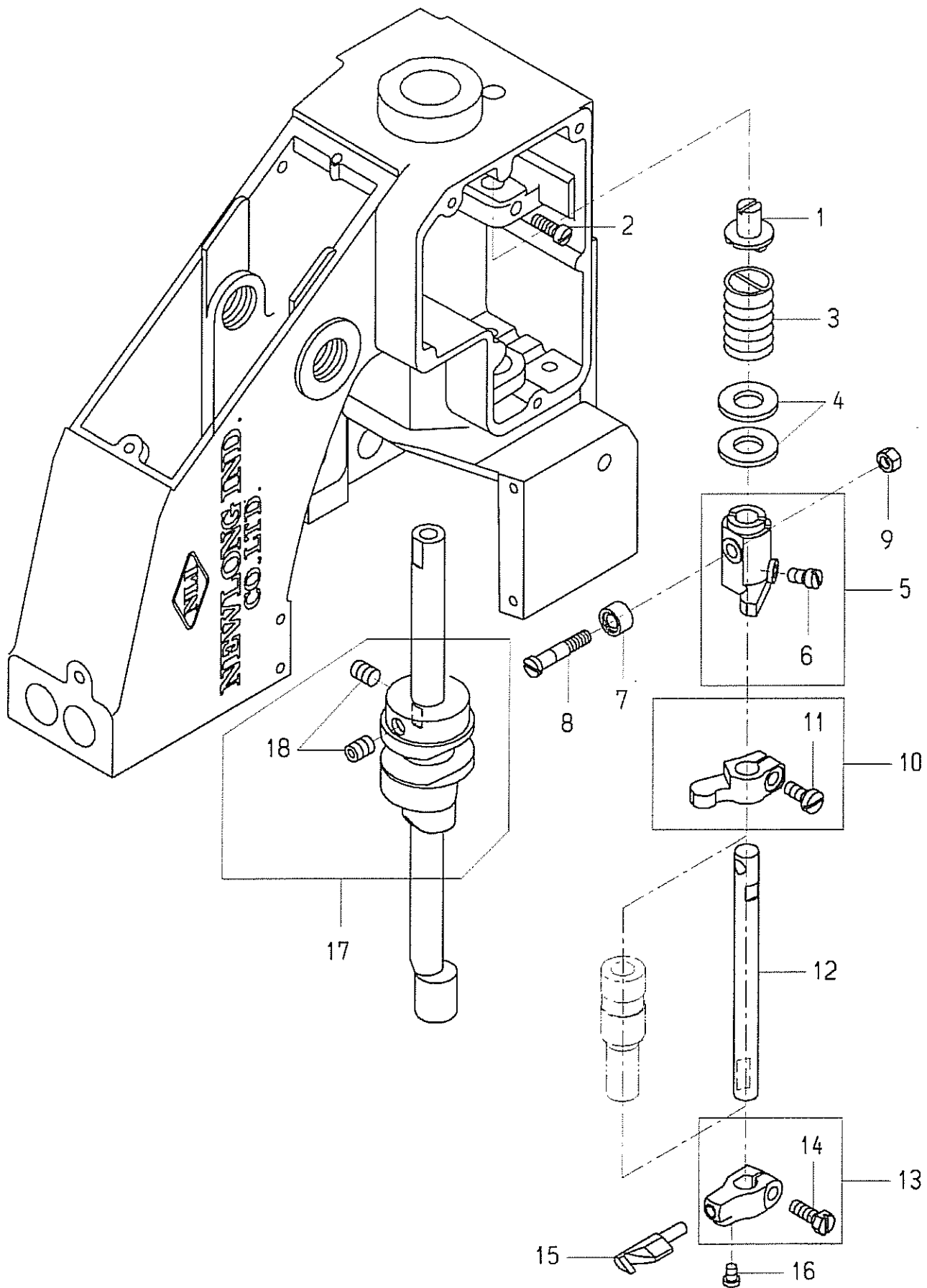

(4) LOOPER DRIVING PARTS

Ref. No.	Part No.	Description	Q'ty	Remarks
1	243121	Spring Supporter	1	
2	11/64S40003	Screw, for 243121	1	
3	243131	Spring	1	
4	205131	Oil Felt	2	
5	243071	Looper Rocker Shaft Arm (A)	1	(6)
6	11/64S40002	Screw, for 243071	1	
7	243041	Roller	1	
8	243061	Roller Stud Screw	1	
9	11/64N40201	Nut, for 243061	1	
10	243081	Looper Rocker Shaft Arm (B)	1	(11)
11	11/64S40009	Screw, for 243081	1	
12	243032	Looper Rocker Shaft	1	
13	243092	Looper Rocker	1	(14)
14	11/64S40089	Screw, for 243092	1	
15	243102	Looper	1	
16	9/64S40001	Screw, for 243102	1	
17	243012	Looper Drive Cam	1	(18)
18	15/64S28526	Screw, for 243012	2	

(5) FEED DRIVING AND THREAD CUTTER PARTS

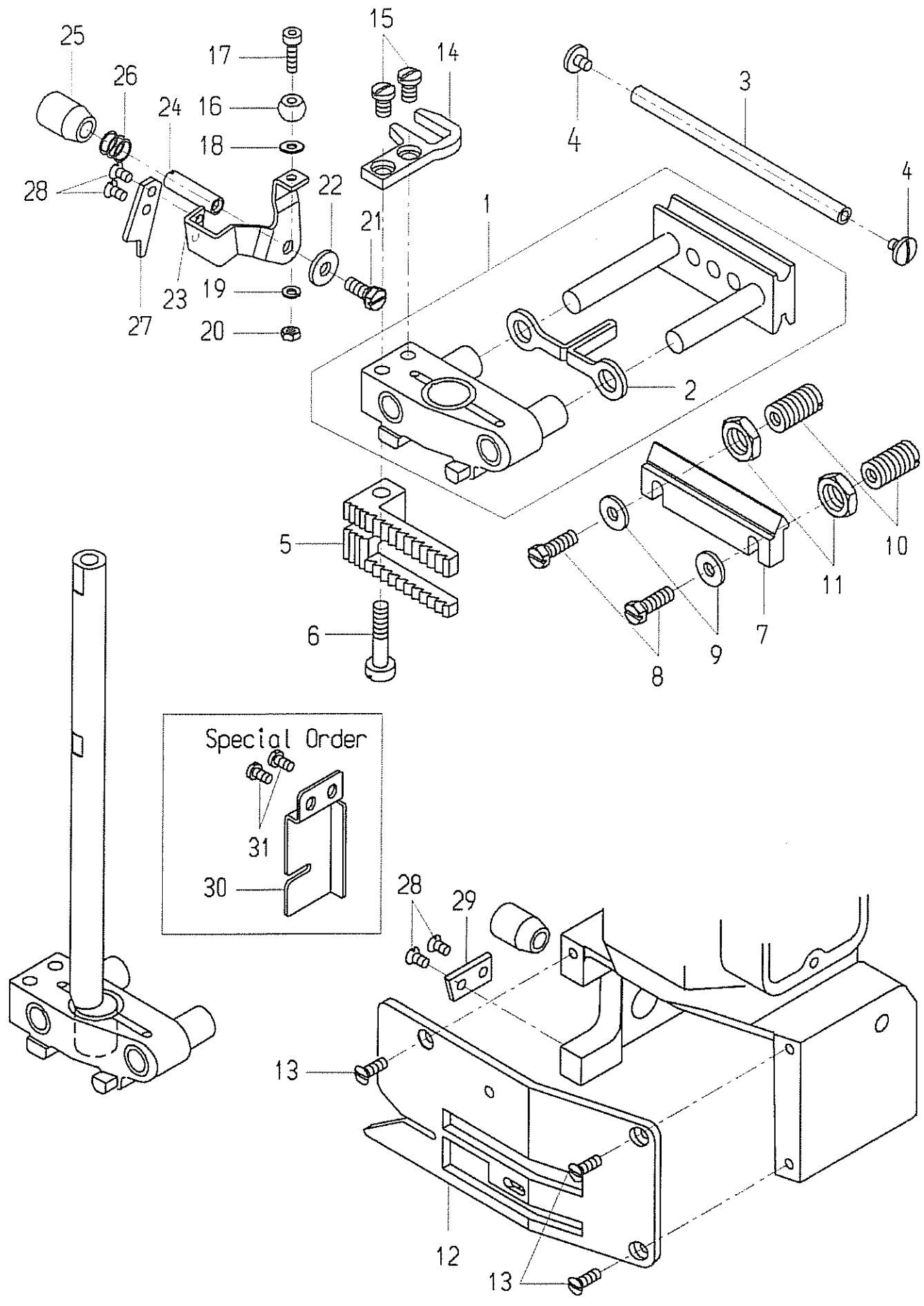

(5) FEED DRIVING AND THREAD CUTTER PARTS

Ref. No.	Part No.	Description	Q' ty	Remarks
1	244011A	Feed Dog Carrier Block Assembly	1	(2)
2	245391	Oil Felt	1	
3	244102	Slide Block Guide Stud	1	
4	9/64S40011	Screw, for 244102	2	
5	244111	Feed Dog	1	
6	3/16S32034	Screw, for 244111	1	
7	244081	Slide Block Adjusting	1	
8	3/16S32025	Lock Bolt, for 244091	2	
9	11/64W15103	Washer, for 244091	2	
10	244091	Stud Slide Block Adjusting Support	2	
11	3/8N24201	Lock Nut, for 244091	2	
12	244122	Throat Plate	1	
13	9/64S40043	Screw, for 244122	3	
14	246011	Knife Bracket Extension	1	
15	3/16S32031	Screw, for 246011	2	
16	246081	Ball	1	
17	4B3×12	Bolt, for 246081 (M3×0.5×12L)	1	
18	1W3	Washer, for 246081 (M3)	1	
19	3W3	Spring Lock Washer (M3)	1	
20	1N3	Nut, for 246081 (M3×0.5)	1	
21	11/64S40049	Screw, for 246021	1	
22	11/64W15103	Washer, for 246021	1	
23	246021	Knife Bracket	1	
24	246032	Knife Bracket Pin	1	
25	246043	Bushing, for 246032	1	
26	246051	Knife Tension Spring	1	
27	246061	Knife Moving	1	
28	1/8S40003	Screw, for 246061,246071	4	
29	246071	Knife Stationary	1	
30	245561	Knife Cover	1	
31	1/8S40006	Screw, for 245561	2	

(U) MOTOR PARTS (FOR Totally Enclosed Type Motor)

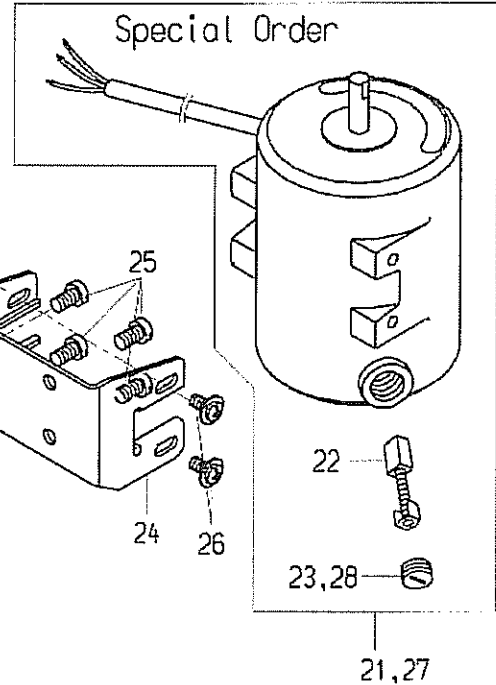
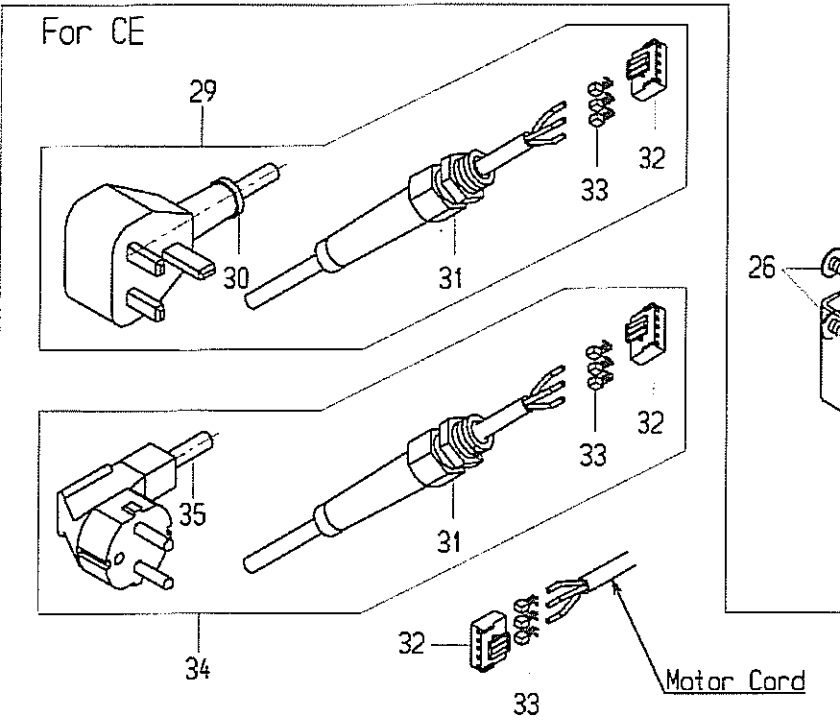
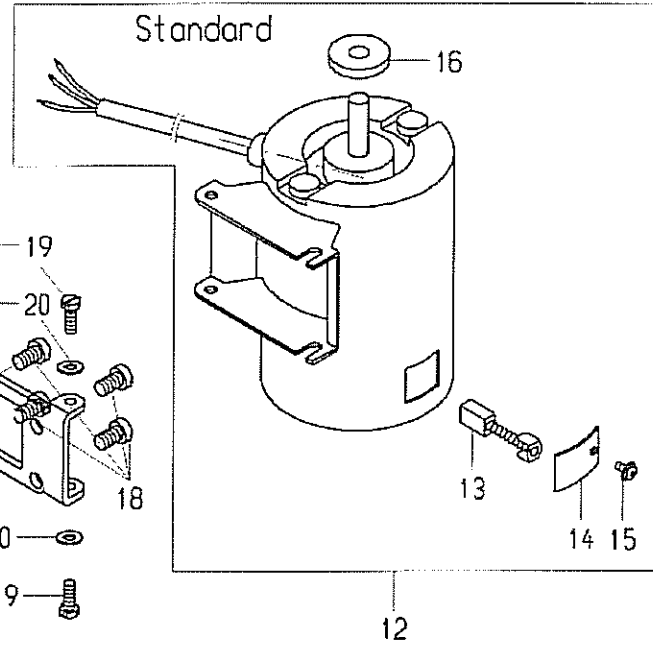
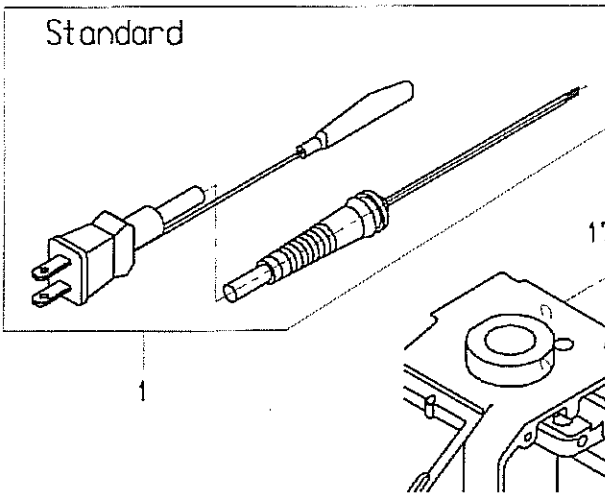
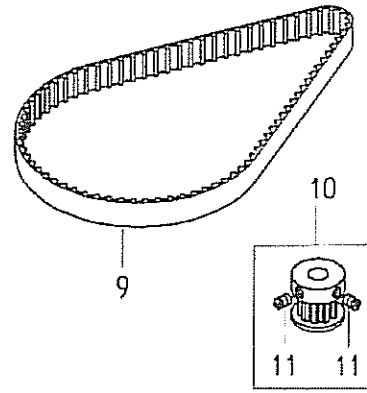
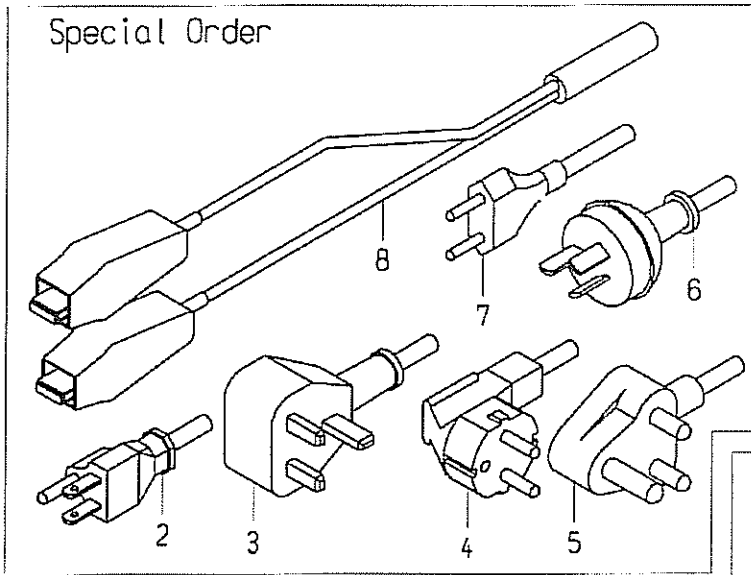

(b) MOTOR PARTS (For Totally Enclosed Type Motor)

Ref. No.	Part No.	Description	Q' ty	Remarks
1	C04001	Cabtyer Cord, with Plug (Standard Type)	1	
2	C04003	Cabtyer Cord, with Plug (American Type)	(1)	
3	C04004	Cabtyer Cord, with Plug (British Type)	(1)	
4	C04005	Cabtyer Cord, with Plug (German Type)	(1)	
5	C04013	Cabtyer Cord, with Plug (South Africa Type)	(1)	
6	C04007	Cabtyer Cord, with Plug (Australian Type)	(1)	
7	C04015	Cabtyer Cord, with Plug (Indonesia Type)	(1)	
8	C04009	Cabtyer Cord, with Plug (for DC Motor)	(1)	
9	F01001	Timing Belt	1	
10	241083	Motor Pulley	1	(5)
11	11/64S40504	Screw, for 241083	2	
12	C01028	Universal Motor (SM73BP-220)	1	(13-16)
	C01029	Universal Motor (SM73BP-240)	(1)	(13-16)
	C01030	Universal Motor (SM73BP-110)	(1)	(13-16)
	C01032	motor (DC.24V)	(1)	(13-16)
	C01033	motor (DC.12V)	(1)	(13-16)
13	C08004	Carbon Brush, for AC Motor	(2)	
	C08005	Carbon Brush, for DC Motor	(2)	
14	C07003	Cap, for C01028, C01029, C01030, C01032, C01033	(2)	
15	4S3×6-W	Screw	(2)	
16	C07005	Rubber Ring	(1)	
17	241073	Motor Base B	1	
18	15/64S28004	Screw, for 241073	4	
19	11/64S40075	Screw, for Motor	4	
20	11/64W10101	Washer, for Motor	4	
21	C01021	Universal Motor (UM81-220)	(1)	(22, 23)
	C01022	Universal Motor (UM81-240)	(1)	(22, 23)
	C01023	Universal Motor (UM81-110)	(1)	(22, 23)
22	C08008	Carbon Brush, for AC Motor	2	
23	C07004	Cap, for C01021, C01022, C01023	2	
24	241075	Motor Base	1	
25	15/64S28004	Screw, for 241075	4	
26	13S5×10	Screw, for Motor	4	
27	C01046	Universal Motor (SM81-110)	(1)	(22, 28)
	C01047	Universal Motor (SM81-220)	(1)	(22, 28)
	C01048	Universal Motor (SM81-240)	(1)	(22, 28)
28	C07001	Cap, for C01046, C01047, C01048	(2)	
29	C04010A	Cabtyer Cord Ass'y	(1)	(30-33)
30	C04010	Cabtyer Cord, with Plug (British Type)	(1)	
31	C06004	Cable Clamp (SKIN TOP BS-9)	(1)	
32	C05010	Connector Housing (VHR-5N)	(2)	
33	C05011	Contact (BVH-21T-P1.1)	(6)	
34	C04011A	Cabtyer Cord Ass'y	(1)	(31-33,35)
35	C04011	Cabtyer Cord, with Plug (German Type)	(1)	

(7) SPECIAL PARTS FOR NF 711

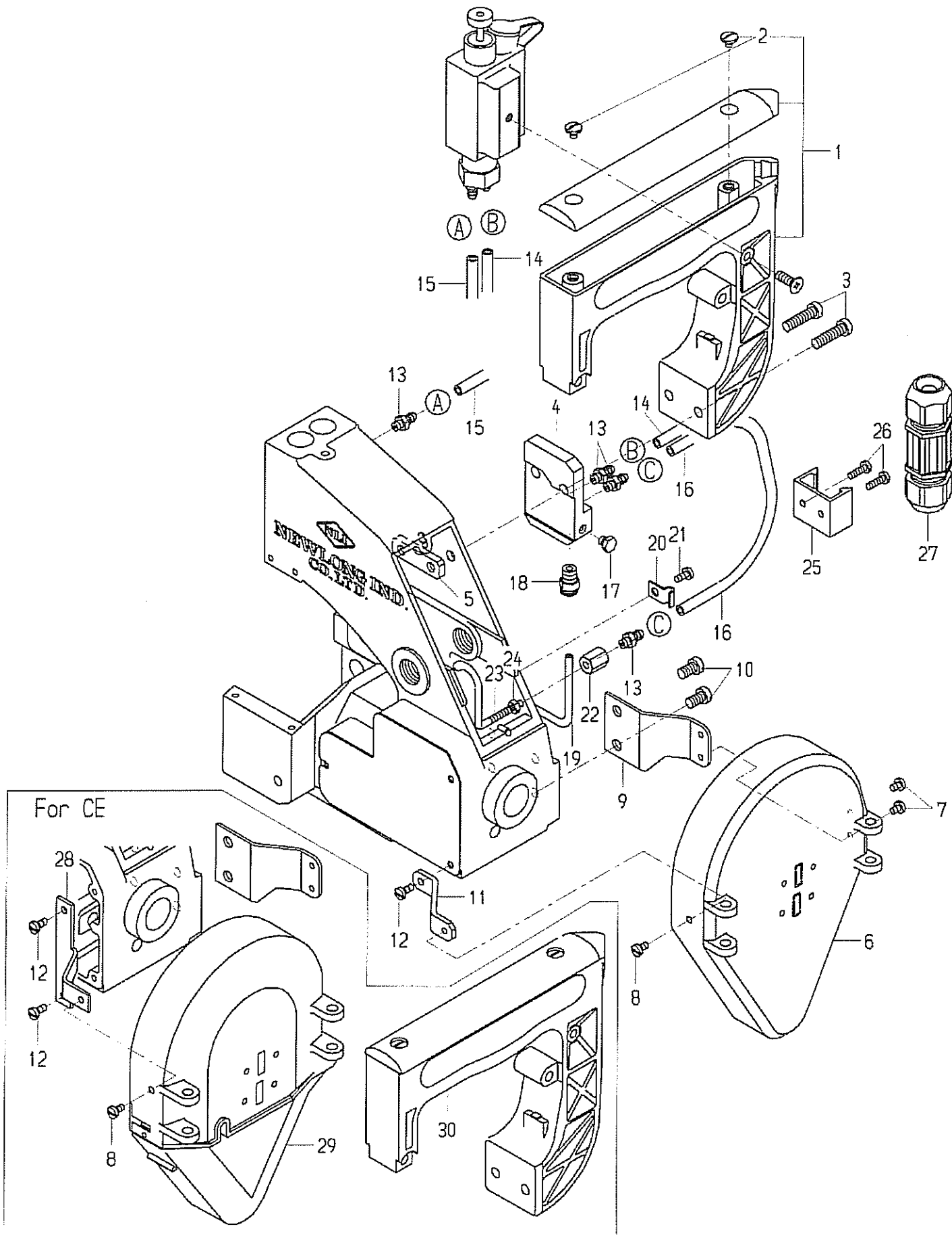

(7) SPECIAL PARTS FOR NP-7H

Ref. No.	Part No.	Description	Q'ty	Remarks
1	241024	Handle	1	(2)
2	9/64S40011	Screw	2	
3	15/64S28032	Screw, for 241253	2	
4	241223	Handle Base	1	
5	241253	Handle Base Holder	1	
6	241212	Pulley Cover	1	
7	9/64S40004	Screw, for 241053	2	
8	9/64S40052	Screw, for 241053	1	
9	241242	Pulley Cover Holder A	1	
10	15/64S28004	Screw, for 241242	2	
11	241231	Pulley Cover Holder B	1	
12	9/64S40005	Screw, for 241231	1	
13	D07021	Joint (BN-5-6)	2	
14	8FU2-6×95F	Oil Tube (ϕ 6×95L), with oil felt	2	
15	8FU2-6×70F	Oil Tube (ϕ 6×70L), with oil felt	1	
16	8FU2-6×210F	Oil Tube, with oil wick	1	
17	D07044	Plug	1	
18	D07057	Joint	1	
19	8FN2-4×135K	Oil Tube (ϕ 4×135L), with oil wick	1	
20	D07009	Tube Clip (PC-4-1)	1	
21	9/64S40005	Screw, for D07009	1	
22	245471	Joint	1	
23	245462	Oil Pipe	1	
24	1N4	Nut	1	
25	C06006	Holder	1	
26	9/64S40035	Screw for C06006	2	
27	C06005	SC Lock	1	
28	XS3021	Pulley Cover Holder B	(1)	
29	XS3020	Pulley Cover	(1)	
30	XS3022	Handle	(1)	(2)

(6) CREPE TAPE BINDING AND CUTTER PARTS (Special Order Parts)

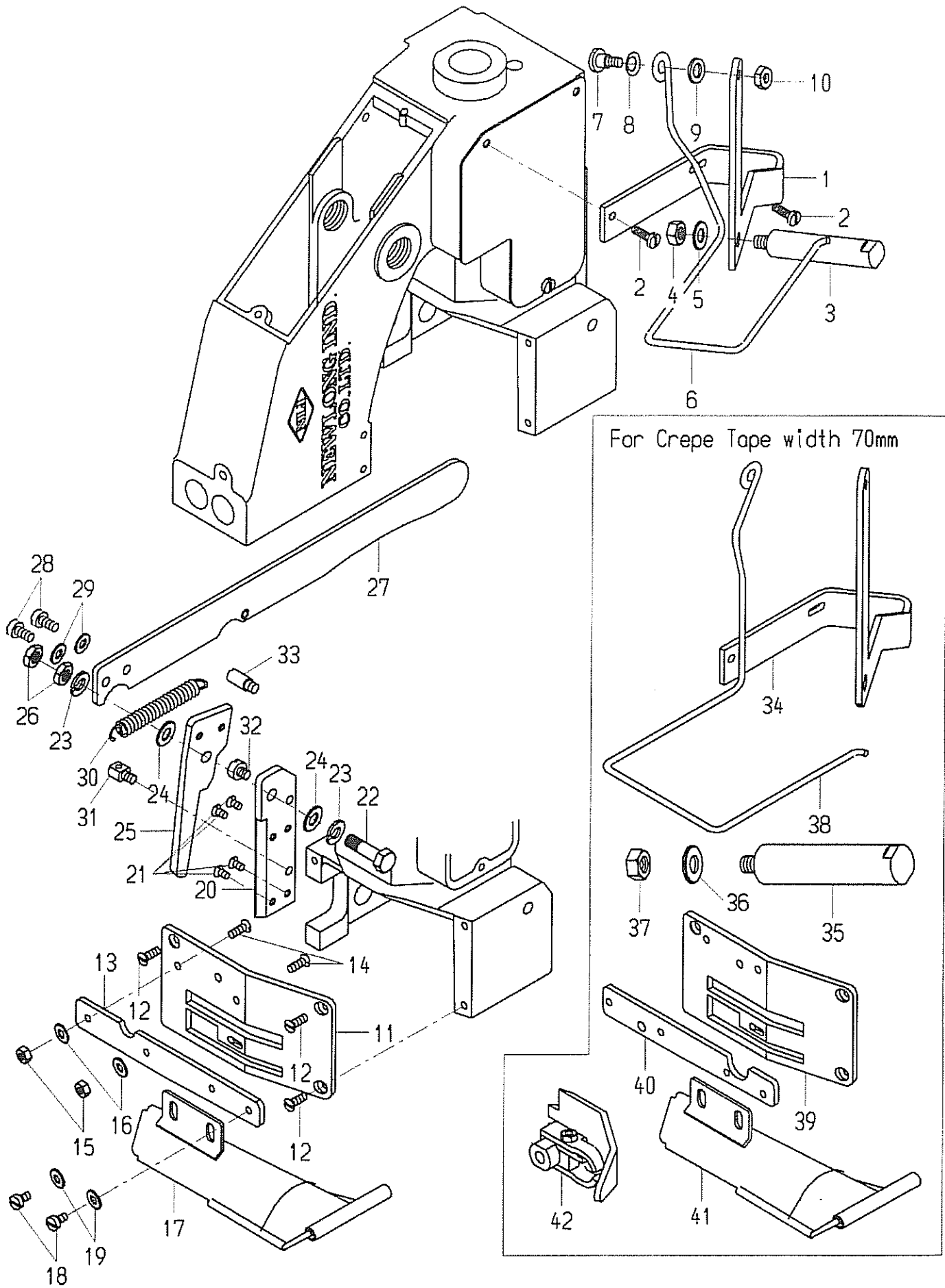

(6) CREPE TAPE BINDING AND CUTLER PARTS (Special Order Parts)

Ref.No.	Part No.	Description	Q'ty	Remarks
1	247071	Crepe Tape Bracket	1	
2	247091	Crepe Tape Hanger Stud	1	
3	9/64S40035	Screw, for 247071	2	
4	1N6	Nut, for 247091 (M6)	1	
5	2W6	Washer, for 247091 (M6)	1	
6	247081	Crepe Tape Supporter	1	
7	11/64S40015	Screw, for 247071	1	
8	1/4W03205	Spring Washer, for 247071	1	
9	1/4W15105	Washer, for 247071	1	
10	11/64N40203	Nut, for 247071	1	
11	244132	Throat Plate	1	
12	9/64S40043	Screw, for 244132	3	
13	247051	Holder, for crepe tape binder	1	
14	9/64S40043	Screw, for 247051	2	
15	9/64N40101	Nut, for 247051	2	
16	2W4	Washer, for 247051 (M4)	2	
17	247061	Crepe Tape binder	1	
18	9/64S40054	Screw, for 247061	2	
19	2W4	Washer, for 247061 (M4)	2	
20	247001	Knife, Stationary	1	
21	1/8S40003	Screw, for 247001	4	
22	247021	Hinge Pin	1	
23	3W6	Spring Lock Washer, for 247021,(M6)	2	
24	2W6	Washer, for 247021,(M6)	2	
25	247011	Knife, Moving	1	
26	15/64N28206	Nut, for 247021	2	
27	247031	Cutter Lever	1	
28	11/64S40046	Screw, for 247011	2	
29	11/64W10101	Washer, for 247011	2	
30	247041	Spring	1	
31	183261	Spring Hook	1	
32	11/64S40029	Stopper Screw, for 247011	1	
33	3/16S32026	Stopper Screw, for 247031	1	
34	247073	Crepe Tape Bracket	(1)	
35	247092	Crepe Tape Hanger Stud	(1)	
36	2W8	Washer	(1)	
37	1N8	Nut	(1)	
38	247082	Crepe Tape Supporter	(1)	
39	244133	Throat Plate	(1)	
40	247052	Holder, for crepe tape binder	(1)	
41	247063	Crepe tape Binder	(1)	
42	242261A	Presser Foot Assembly	(1)	

NUMERICAL INDEX OF PARTS

PART NO.	PAGE	PART NO.	PAGE	PART NO.	PAGE	PART NO.	PAGE
065261	11-14	242233A	15-45	245461	13-20	OTHER ITEMS	
065401	13-16	242261A	25-42	245462	23-23		
183261	25-31	242271	15-47	245471	13-18,23-22	6A04001	15-14
205131	15-6,17-4	243012	17-17	245481	11-24	B01002	15-34
205171	15-30	243021	13-26	245491	15-20	C01021	21-21
241024	13-3,23-1	243032	17-12	245541	13-24	C01022	21-21
241024A	13-2	243041	17-7	245551	11-11	C01023	21-21
241024AS	13-1	243061	17-8	245561	19-30	C01028	21-12
241024B	13-29	243071	17-5	245571	11-33	C01029	21-12
241024BS	13-28	243081	17-10	246011	19-14	C01030	21-12
241024D	13-32	243092	17-13	246021	19-23	C01032	21-12
241024DS	13-31	243102	17-15	246032	19-24	C01033	21-12
241073	21-17	243121	17-1	246043	19-25	C01046	21-27
241075	21-24	243131	17-3	246051	19-26	C01047	21-27
241083	21-10	244011A	19-1	246061	19-27	C01048	21-27
241092	15-1	244081	19-7	246071	19-29	C02001	13-6
241102	15-7	244091	19-10	246081	19-16	C02006	13-6
241111	13-25	244102	19-3	247001	25-31	C04001	21-1
241122	13-15	244111	19-5	247011	25-25	C04003	21-2
241131	15-3	244122	19-12	247021	25-22	C04004	21-3
241151	11-29	244132	25-11	247031	25-27	C04005	21-4
241161	15-5	244133	25-39	247041	25-30	C04007	21-6
241212	23-6	245014	11-9	247051	25-13	C04009	21-8
241224	23-4	245022	11-22	247052	25-40	C04010	21-30
241231	23-11	245033	11-18	247061	25-17	C04010A	21-29
241242	23-9	245042	11-1	247063	25-41	C04011	21-35
241253	23-5	245052	11-7	247071	25-1	C04011A	21-34
242011	15-9	245081C	11-12	247073	25-34	C04013	21-5
242011A	15-8	245081	11-13	247081	25-6	C04015	21-7
242031	15-19	245092	11-16	247082	25-38	C05008	13-7
242041	15-18	245101	11-15	247091	25-2	C05010	21-32
242051A	15-26	245132	13-5	247092	25-35	C05011	21-33
242071	15-24	245133	13-33	255351	13-14	C06004	21-31
242081	15-23	245162	13-27	XS3020	23-29	C06005	23-27
242101A	15-29	245171	11-31	XS3021	23-28	C06006	23-25
242121A	15-32	245181	11-27	XS3022	23-30	C07001	21-28
242131	15-33	245201	11-8			C07003	21-14
242161	15-46	245211	15-21			C07004	21-23
242172	15-35	245222	11-21			C07005	21-16
242181	15-38	245231	15-25			C08004	21-13
242191	15-40	245271	11-28			C08005	21-13
242201	15-37	245302	11-25			C08008	21-22
242212	13-21	245371	15-28			C09002	13-34
242222	13-23	245391	19-2			D03003	13-8
242231A	15-41	245411	15-21			D07009	23-20

								
9/64S40504	11/64S40502	11/64S40504	15/64S28526	1/8S40003	1/8S40006	9/64S40001	9/64S40004	9/64S40005
								
9/64S40011	9/64S40035	9/64S40043	9/64S40052	9/64S40054	9/64S40065	11/64S40001	11/64S40002	9/64S40055
								
11/64S40003	11/64S40004	11/64S40005	11/64S40009	11/64S40015	11/64S40029	11/64S40046	11/64S40049	3/16S32034
								
11/64S40075	11/64S40084	11/64S40089	3/16S28009	3/16S32025	3/16S32026	3/16S32031	15/64S28004	
								
15/64S28021	15/64S28028	4B3x12	4B5x15	4S3x6-W	6S5x15	9S2.6x10	13S5x10	15/64S28032
								
9/64N40101	11/64N40201	11/64N40203	15/64N28206	3/8N24201	5/8N18101			
								
1N3	1N4	1N6	1N8		11/64W10101	11/64W15103	1/4W03205	1/4W15105
								
1W3	2W4	2W6	2W8	3W3	3W6	5W8		

NUMERICAL INDEX OF PARTS

PART NO.	PAGE	PART NO.	PAGE	PART NO.	PAGE	PART NO.	PAGE
D07021	13-17,23-13	SCREW		4B3×12	19-17		
D07044	23-17			4B5×15	15-10		
D07057	23-18	1/8S40003	19-28,25-32	4S3×6-W	21-15		
F01001	21-9	1/8S40006	11-30,19-31	6S5×15	13-12		
K01001	11-6	3/16S28009	15-2	9S2.6×10	13-30		
8FN2-4×135K	23-19	3/16S32025	19-8	13S5×10	21-26		
8FU2-6×60F	13-10	3/16S32026	25-28				
8FU2-6×70F	23-15	3/16S32031	19-15				
8FU2-6×90F	13-10	3/16S32034	19-6				
8FU2-6×95F	23-14	9/64S40001	17-16	NUT			
8FU2-6×210F	23-16	9/64S40004	23-7	1N3	19-20		
MW-6.5	11-32	9/64S40005	11-10,11-17	1N4	13-19,23-24		
31LP6	15-48		11-23,11-26	1N6	11-3,25-4		
31LP16	13-35		11-34,23-9	1N8	15-12,25-37		
			23-21	3/8N24201	19-11		
		9/64S40011	13-4,19-4	5/8N18101	15-22		
			23-2	9/64N40101	15-43,25-15		
		9/64S40035	23-26,25-3	11/64N40201	17-9		
		9/64S40043	19-13,25-12	11/64N40203	25-10		
			25-14	15/64N28206	25-24		
		9/64S40052	23-8				
		9/64S40054	25-18	WASHER			
		9/64S40055	15-42				
		9/64S40065	11-20	1W3	19-18		
		9/64S40504	13-22	2W4	25-16,25-19		
		11/64S40001	15-11	2W6	11-5,25-5		
		11/64S40002	15-36,17-6		25-26		
		11/64S40003	15-31,15-39	2W8	25-36		
			17-2				
		11/64S40004	15-27	3W3	19-19		
		11/64S40005	11-19,15-44	3W6	11-4,25-25		
		11/64S40009	15-50,17-11	5W8	15-13		
		11/64S40015	25-7	1/4W03205	25-8		
		11/64S40029	25-27	1/4W15105	25-9		
		11/64S40046	25-21				
		11/64S40049	19-21	11/64W10101	25-22,21-20		
		11/64S40075	21-19	11/64W15103	15-16,15-49		
		11/64S40084	15-15		19-9,19-22		
		11/64S40089	17-14				
		11/64S40502	15-4				
		11/64S40504	21-11				
		15/64S28004	23-10,21-18				
			21-25				
		15/64S28021	13-13				
		15/64S28028	11-2				
		15/64S28032	23-3				
		15/64S28526	17-18				

Warning on Residual Risk!

The machine has operational hazardous areas as indicated below. Use particular care for these areas when operating the machine for closing bags, threading, or otherwise handling it for checking or maintenance. Observe the instructions below to protect the operator or any other person who may use or handle this machine from possible person injuries.

- ① The machine is designed to be used and controlled by the right, not the left, hand of an operator. Be sure to grip the handle by the right hand even when the operator is left-handed. Keep a clearance of at least 150mm between the hand of the operator holding the bag and the machine body. This is necessary to prevent the operator's hand from being caught by the machine in operation.
- ② The needle holder at the tip of the needle bar is not provided with a safety cover. Do not touch the needle and the needle holder when the machine is in operation. When threading or replacing the needle, job the needle bar with the switch until it reaches a suitable position and then threading or replacing the needle.
- ③ An opening is provided on the needle bar guard to allow threading. Do not touch the guard when the machine is in operation. When threading the needle bar guard, always remove the power cable from power supply.
- ④ When turning the machine by hand for replacing parts or adjusting, always remove the power cable from power supply. Open the motor pulley cover by removing the stopper screw. The machine can be turned when the motor pulley is turned by hand. Be sure to close the cover and fix it with the stopper screw before starting the machine.
- ⑤ The Noise of this machine is 75dB(A)~84dB(A).
This Noise level is not an abnormal state of the machine.

Acceleration Value of Vibration

- ① Acceleration value of vibration (weighted root mean square acceleration value) at the handle is as indicated below.

② Method and Condition of Measurement

- 1) The machine was suspended, on a leather belt at the handle grip as shown.
- 2) The vibration pick-up (FV-86) was fixed on the flat part of the handle with an M5 screw.
- 3) The machine was run without load with the presser foot (242233A) lifted and without threaded.
- 4) The drive motor was a UM81-240 type with the following specifications:

Voltage : 240V
Frequency : 50Hz
Machine speed : 1,537rpm
Room temperature : 20°C

③ Measuring Equipment

- 1) Vibration meter, type VM-28 Vibration pick-up, type PV-86 Manufacturer : Rion Co.,Ltd.,Tokyo,Japan
- 2) Portable AC voltmeter, type 2013-18, 150/300V
Manufacturer : Yokogawa Electric Mfg.Co.,Ltd.,Tokyo,Japan
- 3) Digital stroboscope (revolution indicator), type DT-301
Manufacturer : Shimpo Industrial Co.,Ltd.,Kyoto,Japan

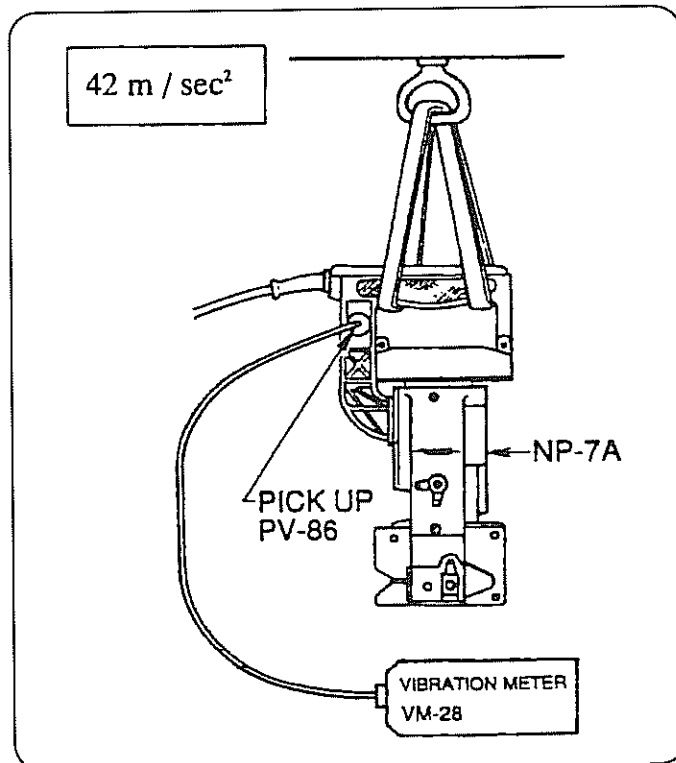
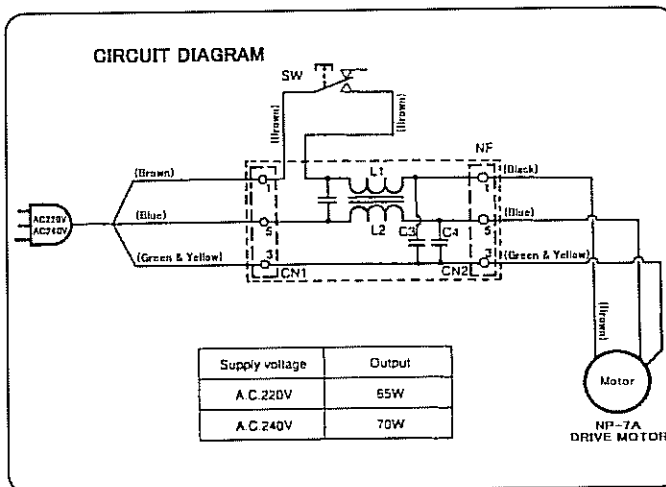
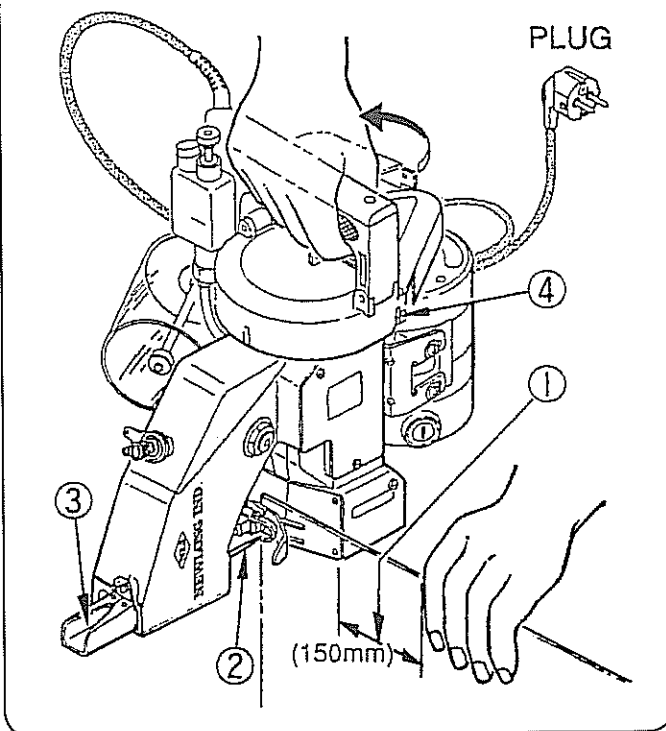

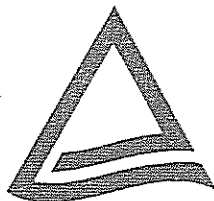

TÜV Rheinland
Technischer Überwachungs-Verein Rheinland

Certificate of Compliance

No. I-9660869-9607

Regarding the certification of products which are in the scope of the
Council Directive 89/336/EEC
the applicant

Fujioka Newlong Industrial Co., Ltd.
4254 Fujioka, Fujioka-machi,
Shimotsuga-gun, Tochigi-ken, 349-13, Japan
has successfully demonstrated that its product

**Portable Bag Closing Machine
NP-7A**

Serial Number: UM81-220

is in compliance with
EN 55 104:1995 (category I)
EN 55 014:1993 (Class B)
EN 61000-3-2:1995
EN 61000-3-3:1995

as described in the Technical Report P 9660869E01.

This Certificate is based on a single evaluation of one sample of the above mentioned
product. It does not imply an assessment of the whole production and does not permit the use
of a licenced test mark of TÜV Rheinland.

TÜV Rheinland Product Safety GmbH
Shin Yokohama, 26.07.1996

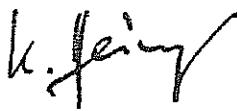

Dipl.-Ing. K. Heinz
Certification Centre





Dipl.-Phys. J. Iden
Testing Centre



The CE marking may only be used if all relevant and effective EC Directives are complied with.



The conditions of the Testing and Certification Regulations are an integral part of this certificate.

**CERTIFICATE
of Conformity**

**EEC Directive 89/392/EEC
as last amended by EEC Directive 93/68/EEC
Machines**

Registration No.: AM-9650739 01

Report No.: E 9660425 E 02

The Holder of Certificate

Fujioka Newlong Industrial Co.,Ltd.
4254 Fujioka, Fujioka-machi
Shimotsuga-gun, Tochigi, 349-13 Japan

has demonstrated that its

Product : Sewing Machine

Identification

Model designation : NP-7A

Serial No. : 114800

is in conformity with all provisions of Annex I of Council Directive 89/392/EEC, in its latest amended version, referred to as the EC Machinery Directive.

This Certificate of Conformity is based on an evaluation of a sample of the above mentioned product as documented in the Technical Report. It does not imply an assessment of the whole production and does not permit the use of a mark of conformity of TÜV Rheinland. The holder of certificate is authorized to use this Certificate of Conformity in connection with the EC-declaration of conformity according to Annex V of the Directive.



Cologne, 14.08.1996

Certification Body

i. A.

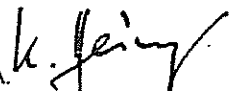
Dipl.-Ing. P. Pape

TÜV Rheinland Product Safety GmbH - Am Grauen Stein - D-51105 Köln

CE The CE marking may only be used if all relevant and effective EC Directives are complied with. **CE**

