

## Product Manual

# Ridder MotorControl RMC400

265047EN - V03 - 2016.12

### Ridder Drive Systems

Lorentzstraat 36-38 3846 AX Harderwijk  
 P.O. Box 360 3840 AJ Harderwijk  
 The Netherlands

T +31 (0)341 416 854 F +31 (0)341 416 611  
 I www.ridder.com E info@ridder.com



## TABLE OF CONTENTS

<b>1.</b>	<b>GUIDELINES, STANDARDS AND CONDITIONS</b>	
1.1	Applicable guidelines and standards . . . . .	3
1.2	Qualified personnel . . . . .	3
1.3	Warning regarding discouraged use . . . . .	3
1.4	Warranty provisions . . . . .	3
<b>2.</b>	<b>SYMBOLS, WARNINGS AND SAFETY INSTRUCTIONS</b>	
2.1	Explanation of warnings (ISO 3864-2) . . . . .	3
<b>3.</b>	<b>PRODUCT DETAILS</b>	
3.1	Description . . . . .	4
3.2	Application . . . . .	4
3.3	Dimensions . . . . .	4
3.4	Technical specifications . . . . .	5
3.5	Item numbers and models . . . . .	7
<b>4.</b>	<b>MOUNTING INSTRUCTIONS</b>	
4.1	Special tools and equipment . . . . .	7
4.2	Mounting . . . . .	8
<b>5.</b>	<b>CONNECTION INSTRUCTIONS</b>	
	<b>GENERAL</b>	
5.1.1	Connection and operation - abbreviations . . . . .	8
5.1.2	Connecting the components, switching devices and cables . . . . .	8
5.1.3	Overview and function diagram . . . . .	9
5.1.4	Wiring diagram general: Control board (RCB) . . . . .	9
	<b>CONNECTIONS: STANDARD</b>	
5.2.1	Connections: Protection . . . . .	10
5.2.2	Connections: 3-phase electric motor (208-600 VAC) . . . . .	11
5.2.3	Connections: 1-phase 3-wire electric motor (115-230 VAC) . . . . .	11
5.2.4	Connections: 1-phase 5-wire electric motor (115-230 VAC) . . . . .	12
5.2.5	Connections: Limit switch (RSU/RLS) . . . . .	12
5.2.6	Connections: Automatic control (ACS) (24 V AC/DC) . . . . .	13
	<b>CONNECTIONS: OPTIONS</b>	
5.3.1	Connections: Manual control (MC) - <b>OPTION</b> . . . . .	13
5.3.2	Connections: Digital position sensor (RPU) - <b>OPTION</b> . . . . .	14
5.3.3	Connections: Fault contact - Alarm (AL) - <b>OPTION</b> . . . . .	15
<b>6.</b>	<b>USER INSTRUCTIONS</b>	
6.1	Status LEDs . . . . .	16
6.2	Safety functions and stop features . . . . .	16
6.3	Operation . . . . .	17
<b>7.</b>	<b>COMMISSIONING INSTRUCTIONS</b>	
7.1	Commissioning . . . . .	18
7.2	Checking: Switching sense Limit Switch (RSU/RLS) . . . . .	18
7.3	Checking: Direction Automatic Control (ACS) . . . . .	19
7.4	Checking: Direction Manual Control (MC) . . . . .	20
<b>8.</b>	<b>MAINTENANCE INSTRUCTIONS</b>	
8.1	Maintenance . . . . .	20
<b>9.</b>	<b>SERVICE</b>	
9.1	Troubleshooting . . . . .	21
9.2	Blink codes . . . . .	22
9.3	Technical support . . . . .	23
<b>10.</b>	<b>ENVIRONMENT</b>	
10.1	Waste disposal . . . . .	23
10.2	Decommissioning and removal . . . . .	23

## 1.1 Applicable guidelines and standards

---

The Ridder MotorControl RMC400 complies with the provisions of the following European guidelines:

Low Voltage Directive 2006/95/EC | EMC Directive 2004/108/EC

The following harmonized standards (or parts of these standards) have been applied:

NEN-EN-ISO 12100:2010 | NEN-EN-IEC 60204-1 | NEN 82079-1 (62079: 2001) | NEN5509 | ISO 3864-2

This product may only be put into operation if it has been determined that the system in which the product will be installed complies with the requirements of the applicable standards and guidelines.

## 1.2 Qualified personnel

---

This product manual contains important information for installers on how to connect and commission a MotorControl RMC400. First read this product manual and instructions before starting the activities. All activities in this respect should be carried out by qualified and skilled mechanical and/or electrical installers in proper and safe conditions.

## 1.3 Warning regarded discouraged use

---

The following conditions apply when using the RMC400.

- The RMC400 may not be modified or changed.

See section 3.2 for a description of the intended use of the RMC400.

## 1.4 Warranty provisions

---

For the warranty period and conditions, please see the 'Conditions' section on our website at [www.ridder.com](http://www.ridder.com), or in the Ridder catalogue.

## 2.1 Explanation of warnings (ISO 3864-2)

---

This product manual contains tips, notes and warnings of varying degrees of importance. The following list explains what they mean.



**May result in damage or problems if an action is performed incorrectly.**



**May result in minor injury if the hazard is not avoided.**

### 3.1 Description

The RMC400 is an intelligent control unit for the operation of motor gearboxes. All the electrical components of the RMC400 have been integrated into a plastic housing. The RMC400 is suitable for various supply voltages and mains frequencies, and for 3-phase and 1-phase voltages.

The RMC400 has a fully cast-in printed circuit board with a microprocessor and a semiconductor relay. This control board is fitted with a connection for the supply voltage, an automatic control signal (24 V AC/DC), a manual control and an fault contact (NC). The power supply of the electric motor, the PTC thermistor in the electric motor (if applicable), the limit switch system and optional digital position sensor RPU are also connected to the control board of the RMC400.

The RMC400 relays the control commands of the automatic control or manual control unit and checks whether these commands are executed without causing technical faults. The RMC400 is equipped with rotating field detection and phase detection of the supply voltage. The 24 V AC/DC control input is protected against operation in both directions and fast switching. The RMC400 control unit is equipped with a fault contact (NC) and status LEDs for feedback of error situations.

The RMC400 is fitted with plug connectors and terminal strips to connect the cables. The RMC400 is also equipped with cable glands for feeding through the cables to the outside. The insulation protection class of the RMC400 housing is IP55.

### 3.2 Application

The RMC400 is developed for monitoring and controlling Ridder RW motor gearboxes, the RPR PowerRoller and RPD PolyDrives. The RMC400 is based on the Ridder LogicLink RLL300 motor control unit. The control board (RCB) is available in the following 3 types:

**TYPE A (RCB-A):** 1~ 115-230 VAC en 3~ 208-400 VAC

**TYPE B (RCB-B):** 3~ 400 VAC

**TYPE C (RCB-C):** 3~ 440 - 600 VAC

The RMC400 can be used in combination with the following possibilities: thermal protection (PTC), an automatic control 24 V AC/DC (ACS), a manual control (MC), a digital position meter (RPU) and a fault contact which can be part of an alarm circuit.

### 3.3 Dimensions

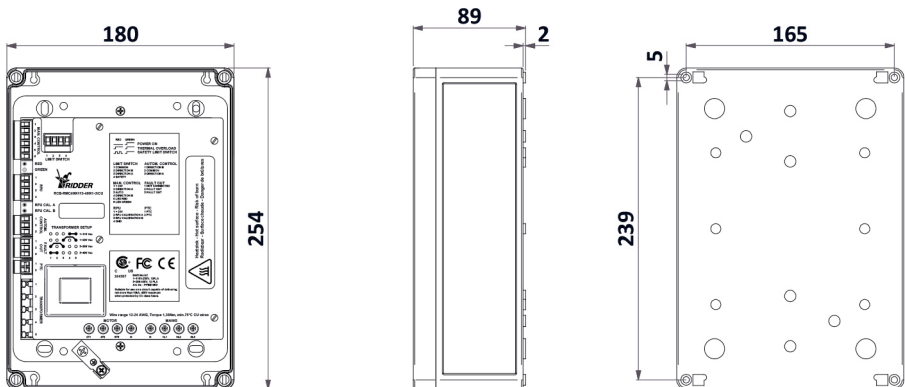

### 3.4 Technical specifications

#### Mechanical

Dimensions (W x H x D) 180 mm x 254 mm x 89 mm

#### Environment

Protection class IP55  
 Operating temperature -10 to 70 °C (14 to 158 °F)  
 Maximum relative humidity 95%

The 3 types of the control board (RCB) as applied in the RMC400 with an overview of all the parts.

#### RCB-A:

50/60 Hz AC  
 1~ 115V-230 V, 12FLA, 72 LRA  
 3~ 208-400 V, 12 FLA, 72 LRA

#### RCB-B:

50/60 Hz AC  
 3~ 400 V, 10 FLA, 60 LRA

#### RCB-C:

50/60 Hz AC  
 3~ 440-600 V, 10 FLA, 60 LRA

See the abbreviations in the following table with technical specifications and a description.

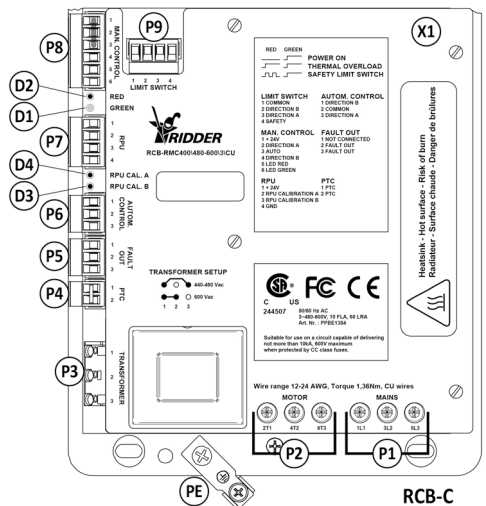
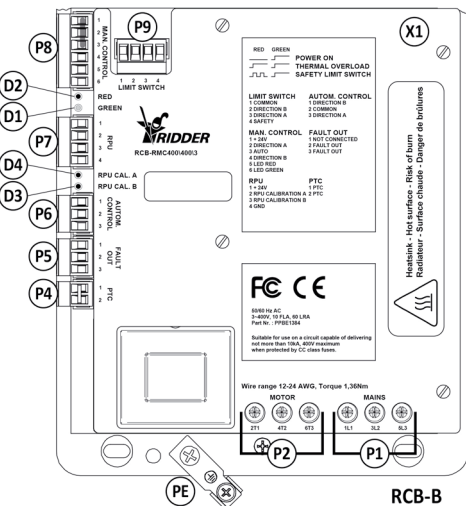
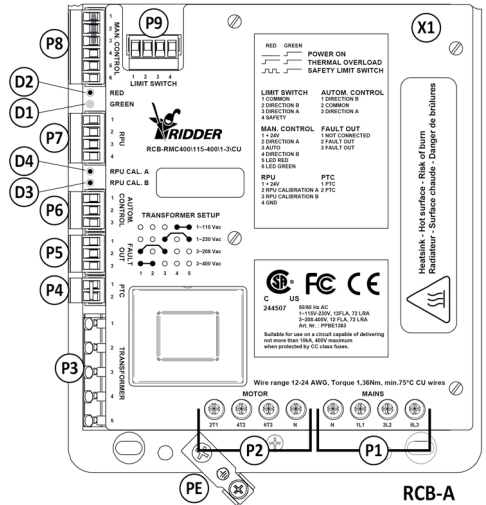

Electrical						
			Supply voltage			
P1	Power supply	Type	1-phase (1~)	3-phase (3~)	Current	
1L1	RCB (X1)	Input	RCB-A 1x 115 VAC 1x 230 VAC	RCB-A - - 3x 208 VAC 3x 400 VAC RCB-B 3x 400 VAC RCB-C 3x 440-480 VAC 3x 600 VAC	Max 12 A	
3L2	RCB (X1)	Input				
5L3	RCB (X1)	Input				
N*	RCB (X1)	Input				
P2	Power supply	Type				
2T1	Electric motor (EM)	Output				
4T2	Electric motor (EM)	Output				
6T3	Electric motor (EM)	Output				
N*	Electric motor (EM)	Output				
*Omitted from RCB-B						
P3	Transformer	Type	Supply voltage		Current	
RCB-A	1 2 3 4 5	Type	1-phase (1~)	3-phase (3~)	Current	
1~		Loop connection	1x 115 VAC	N.A.	~16 mA	
1~		Loop connection	1x 230 VAC	N.A.	~10 mA	
3~		Loop connection	N.A.	3x 208 VAC	~10 mA	
3~		Loop connection	N.A.	3x 400 VAC	~ 4 mA	
(P3)	Transformer	Type	Supply voltage		Current	
RCB-B	1 2 3 4 5	Type	1-phase (1~)	3-phase (3~)	Current	
3~	N.A.	N.A.	N.A.	3x 400 VAC		
P3	Transformer	Type	Supply voltage		Current	
RCB-C	1 2 3	Type	1-phase (1~)	3-phase (3~)	Current	
3~		Loop connection	N.A.	3x 440-480 VAC		
3~		Loop connection	N.A.	3x 600 VAC		
P4	PTC IN	Type	Supply voltage		Current	
1	PTC	Input	0,25 V DC		1 mA	
2	PTC'	Power supply	0,25 V DC		1 mA	
P5	Fault contact OUT	Type	Supply voltage		Current	
1	Not connected	Loop connection pin	Max 350 V		Max 50 mA	
2	Fault OUT	Switching contact	Max 350 V		Max 50 mA	
3	Fault OUT'	Switching contact	Max 350 V		Max 50 mA	
P6	Automatic control	Type	Supply voltage		Current	
1	Direction B	Input	24 V AC/DC		10,5/10 mA	
2	Common	Ground	Ground		10,5/10 mA	
3	Direction A	Input	24 V AC/DC		10,5/10 mA	
P7	RPU	Type	Supply voltage		Current	
1	+24V	Power supply	24 V DC		50 mA	
2	RPU CALIBRATION A	Output	24 V DC		0,5/1 mA	
3	RPU CALIBRATION B	Output	24 V DC		0,5/1 mA	
4	Neutral wire	Power supply	-		-	

Electrical				
P8	Manual control	Type	Supply voltage	Current
1	+24V	Power supply	24 V DC	Max 15,7 mA
2	Direction A	Input	24 V DC	2,1 mA
3	Auto	Input	24 V DC	2,1 mA
4	Direction B	Input	24 V DC	2,1 mA
5	LED	Output	24 V DC	4,7 mA
6	LED	Output	24 V DC	4,7 mA
P9	Limit switch IN	Type	Supply voltage	Current
1	Common	Power supply	7 V DC	3,3 mA
2	Direction B (Dir B)	Input	7 V DC	1,1 mA
3	Direction A (Dir A)	Input	7 V DC	1,1 mA
4	Safety	Input	7 V DC	1,1 mA
LEDs	Indicators			
D1	Green			
D2	Red			
D3	Red (RPU/X5)			
D4	Red (RPU/X5)			

### 3.5 Item numbers and models

The following models of the RMC400 are available.

Item	Description	Type	U - 3~	U - 1~	p	IP
			V	V	Hz	
584820	RMC400-BOX\115-400\1-3\CU	Built-in	208-400	115-230	50/60	55
584825	RMC400-BOX\400\3	Built-in	400		50/60	55
584830	RMC400-BOX\440-600\3\CU	Built-in	440-600		50/60	55

### 4.1 Special tools and equipment

For mounting and connecting a RMC400 no special tools or equipment are needed.

	<p><b>Make sure that you apply the correct equipment and tools.</b></p>
---	---

## 4.2 Mounting

The RMC400 is suitable for wall mounting. You can mount the RMC400 by inserting and tightening 4 screws (up to  $\varnothing 4.5$  mm) in the mounting holes, located in the corners of the housing. The RMC400 provides the user with information about the status of the system by means of LEDs on the control board. It is therefore recommended to place the RMC400 easy accessible and in sight.



**ATTENTION**

**Ensure that the front (cover) remains accessible for connecting and operation.**

### 5.1.1 Connection and operation - abbreviations

Symbol	Description	Symbol	Description
ACS	Automatic control system X7	P4	Connector - PTC input
AL	Alarm(contact) X8	P5	Connector - Fault contact output
Dir A - B	Direction A - B	P6	Connector - Automatic control input
D1	Status LED - Green	P7	Connector - RPU reference input
D2	Status LED - Red	P8	Connector - Manual control input
D3	Status LED - Red	P9	Connector - Limit switch input
D4	Status LED - Red	R	Gearbox (X3)
EM	Electric motor (X3)	RCB	Ridder Control Board X1
L1 ,L2, L3	Voltage source	RLS	Limit switch X4
1L1	Power IN: Control Board (P1)	RPU	Digital positioning meter X5
3L2	Power IN: Control Board (P1)	RSU	Limit switch X4
5L3	Power IN: Control Board (P1)	U1, U2	Motor connection
2T1	Power OUT (P2: to electric motor)	V1, V2	Motor connection
4T2	Power OUT (P2: to electric motor)	W1, W2	Motor connection
6T3	Power OUT (P2: to electric motor)	X0	RMC400 housing
N	Neutral wire	X1	Control board (RCB)
M	Motor (X3)	X2	Manual control (MC)
MC	Manual control (X2)	X3	Motor gearbox
MPCB	Motor Protection Circuit Breaker X6	X4	Limit switch
PE	Protective earth	X5	RPU
P1	Connector - Power input (MAINS)	X6	Motor protection (MPCB)
P2	Connector - Power output (MOTOR)	X7	Automatic control system (ACS)
P3	Connector - Transformer	X8	Alarm

### 5.1.2 Connecting the components, switch devices and cables

A conductor diameter of minimal  $1.5 \text{ mm}^2$  applies to the cables in the wiring diagrams. Depending on the applied components, switch materials and cable lengths etc., a different conductor diameter may be required.



**ATTENTION**

**Please use only suitable components and switch materials.  
Please consult the information of  
the components and switch materials.**



### 5.1.3 Overview and function diagram

The following diagram shows the application of the RMC400 in a system. Components (if applicable) within framework X0 are already connected by **Ridder Drive Systems**.

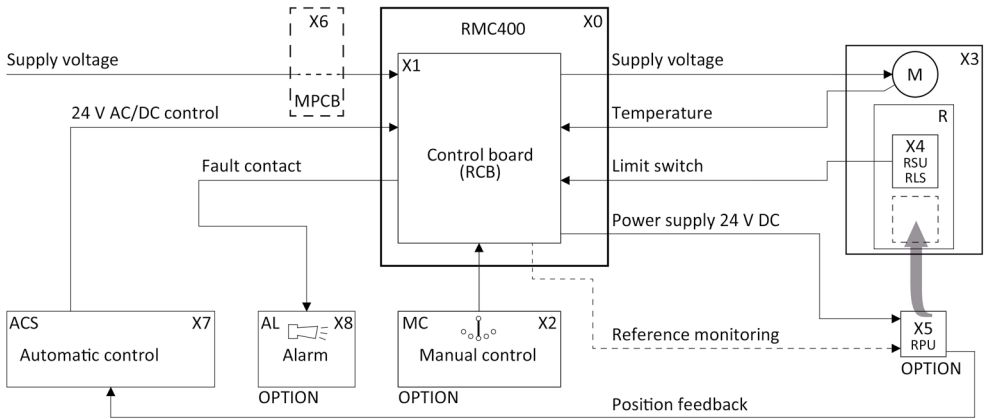

### 5.1.4 Wiring diagram general: Control board (RCB)

In the following diagram of the control board (X1) is displayed:

- The standard connections and options with associated connectors;
- The paragraphs with the wiring diagrams and associated information.

The installer must meet the conditions in §5.2.1 before starting activities.

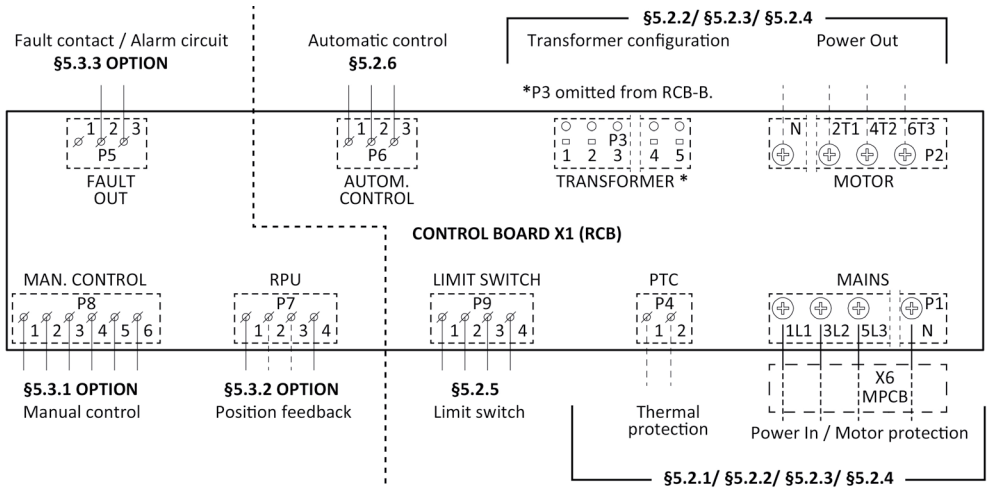

## 5.2.1 Connections: Protection

---

The following conditions apply to the wiring diagrams in this manual.

- The installer makes sure to apply a motor protection circuit breaker (**MPCB**) and other necessary protections.
- Not displayed protections must be included in the wiring diagrams by the installer.
- If applicable, it is possible to connect a PTC thermistor.  
See diagrams §5.2.2, 5.2.3 en 5.2.4.

The following warnings must always be observed.



**The Motor Protection Circuit Breaker (X6) must be set to the value of the nominal current of the electric motor by the installer.**



**Always make sure if the applied protections are in compliance to the, local or national, laws and regulations of the country!**



**The RMC400 is standard not equipped with a short-circuit protection and overload protection. Therefore always install the necessary safety measures according to the local or national laws and regulations of the country.**

### 5.2.2 Connections: 3-phase electric motor (208-600 VAC)

- Configure the transformer of RCB-A or C on P3 for a 3-phase electric motor. The RCB-B control board already has the right configuration.
- When connecting the PTC thermistor, remove the jumper from P4.

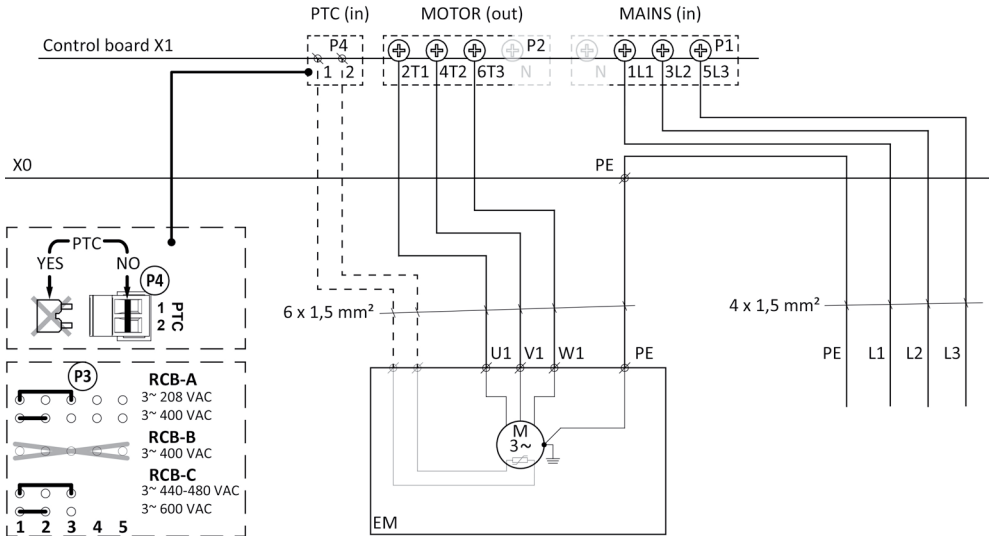

### 5.2.3 Connections: 1-phase 3-wire electric motor (115-230 VAC)

- Configure the transformer of RCB-A on P3 for a 1-phase electric motor.
- When connecting the PTC thermistor, remove the jumper from P4.

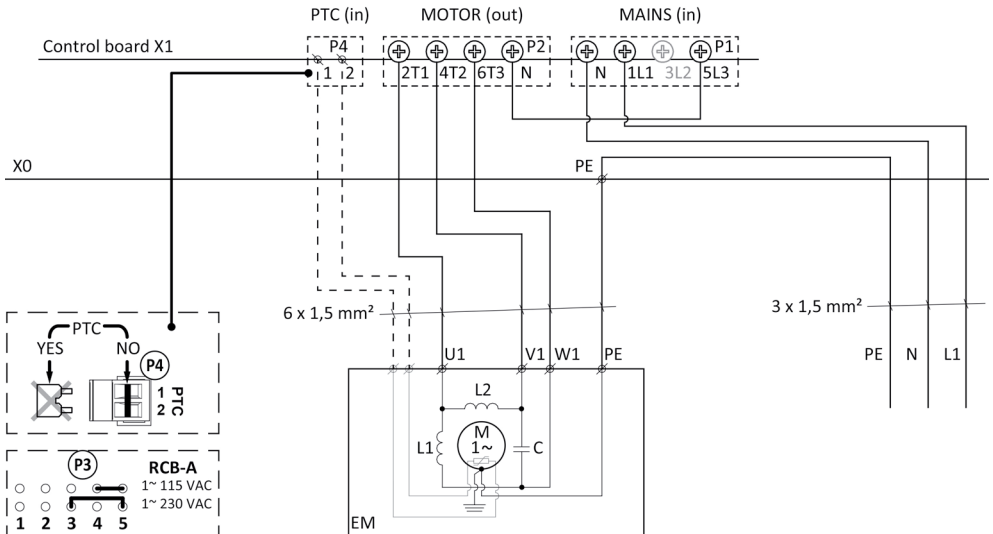

## 5.2.4 Connections: 1-phase 5-wire electric motor (115-230 VAC)

- Configure the transformer of RCB-A on P3 for a 1-phase electric motor.
- When connecting the PTC thermistor, remove the jumper from P4.

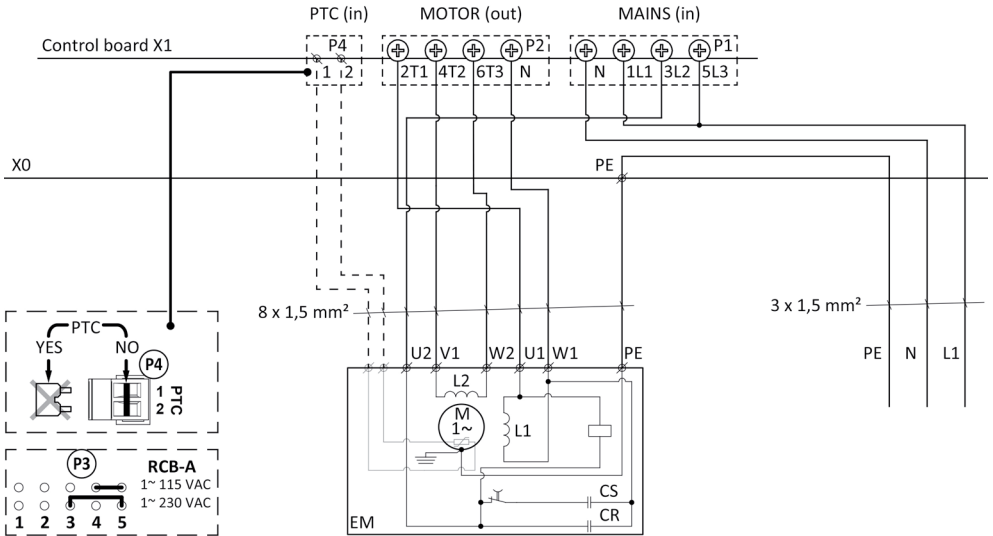

## 5.2.5 Connections: Limit switch (RSU/RLS)

Connect a limit switch (X4) to P9 of the control board (X1) according to the following diagram. Consult also the diagram of the limit switch (X4) from the product manual of the applicable motor gearbox. See [www.ridder.com](http://www.ridder.com).

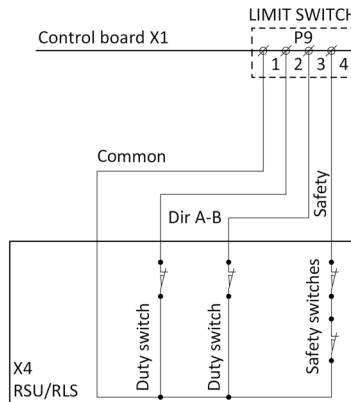

## 5.2.6 Connections: Automatic control (ACS) (24 V AC/DC)

The RMC400 can be connected to an automatic control system (ACS). Connect the automatic control system (ACS) according to the following diagram. Also consult the product manual of the automatic control system (ACS) applied.

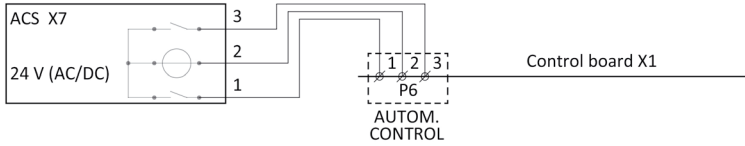

The following remarks and warnings are also important.

- When both inputs of the digital control (pin 1 and 3) receive a control signal simultaneously, the RMC400 will not respond while the electric motor stands still.
- The external power supply is allowed to be 24 V AC/DC.
- See §3.4 for the technical specifications of the external power supply of connector P6.



Connector P6 of control board (X1) is suitable both for connecting an automatic control (ACS) using a “switched **ground**” as with a “switched **positive**”.

## 5.3.1 Connections: Manual control (MC) - OPTION

The RMC400 can be connected to a manual control (X2) such as the Ridder MC Module Compact (277950).

- Remove the jumper from connection 1 and 3 of P8.
- Connect the manual control (X2) according to the following diagram. Consult the accompanying product manual when applying a different manual control (X2).

277950 MC MODULE COMPACT

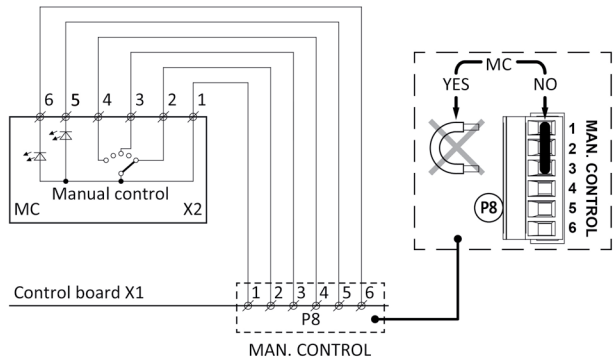
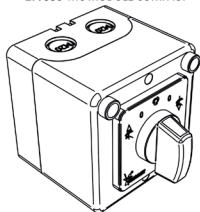

### 5.3.2 Connections: Digital position sensor (RPU) - OPTION

A digital position sensor (RPU) can be connected to the RMC400 and an automatic control system (ACS). Connect the RPU (X5) according to the following diagram ① and procedure ②. Also consult the product manual of the automatic control system (ACS) applied.

#### ① Connecting - Power supply and feedback

- Connect the 24 V power supply (connection 1 and 2) to connector P7 of the control board (X1) (connection 1 and 4).
- Connect the position feedback (connection 3 and 4) to the automatic control system (ACS).

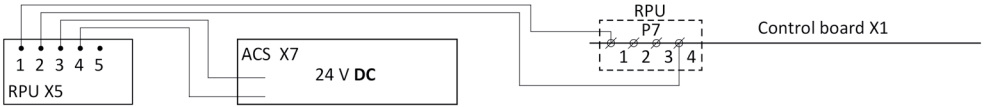

#### ② Connecting - Reference-input RPU

- To use reference monitoring and reset, the reference-input (connection 5) must still be connected.

Follow the procedure for a correct connection of the RPU connector P7.

#### ► Description

- 1 Determine which duty switch (S11 or S12) should function as switch for the RPU reference monitoring. Run the motor in the direction of the chosen duty switch until it switches off.



**When operating the RMC400  
do not exceed the limit positions of the driven system,  
to avoid damage or injury!**

- 2 LED D3 or D4 will light up on control board (X1). Follow the instructions in 3-A or 3-B.  
Blink code is 2.1. The LED D4 (RPU CAL. A) lights up. **See §6.1, 9.1 and 9.2.**  
Go to step 4-A.

3-A

2.1		D3	
		D4	

Blink code is 2.2. The LED D3 (RPU CAL. B) lights up. **See §6.1, 9.1 and 9.2.**  
Go to step 4-B.

3-B

2.2		D3	
		D4	

Connect the reference monitoring to connection 2 of P7. Go to step 5.

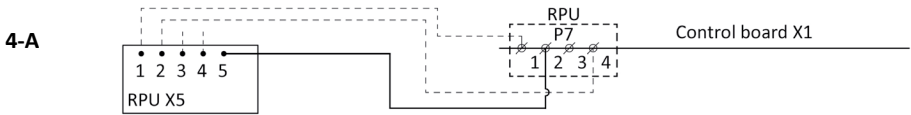

Connect the reference monitoring to connection 3 of P7. Go to step 5.

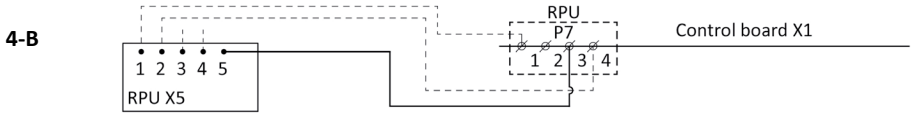

- 5 The RPU is now ready to program the end positions according to the RPU product manual. See [www.ridder.com](http://www.ridder.com).

**ATTENTION** The reference-input of the RPU is **only allowed** to be connected to **P7** of the control board (X1) but **NOT** to the **RSU/RLS**. See also §3.4 (Technical specifications) of P7 and P9.

### 5.3.3 Connections: Fault contact - Alarm (AL) - OPTION

The RMC400 control board (X1) is equipped with an output of a fault contact P5 which opens when a random fault occurs. This fault contact (alarm contact) can be included in an alarm circuit. Connecting single or multiple RMC400 units within an (alarm) circuit is possible.

#### Connecting - Single RMC400 unit

Connect a single RMC400 control unit according to the following diagram.

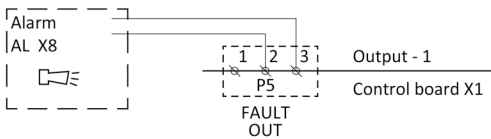

#### Connecting - Multiple RMC400 units

When using multiple RMC400 control units, the fault contact outputs P5 must be connected according to the following diagram.

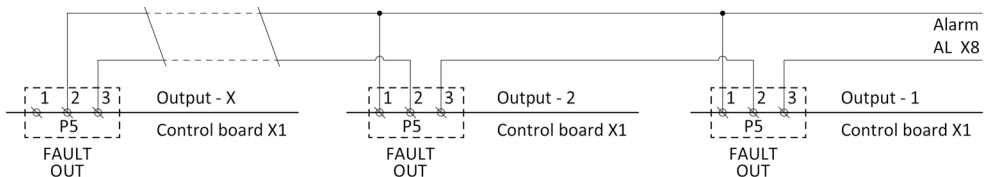

## 6.1 Status LEDs

The RMC400 provides the user with information about the status of the system by means of the 4 LEDs D1 (green), D2 (red), D3 (red) and D4 (red) on the control board (X1). This information may be important for troubleshooting.

See §9.1 and 9.2 for explanation of malfunctions and blink codes that may occur.

If a manual control (X2) (277950) is connected, the 2 LEDs (green and red) correspond with the LEDs D1 and D2 on the control board (X1). Blink Codes (D1 and D2) are displayed simultaneously on the control board (X1) and the manual control (X2).

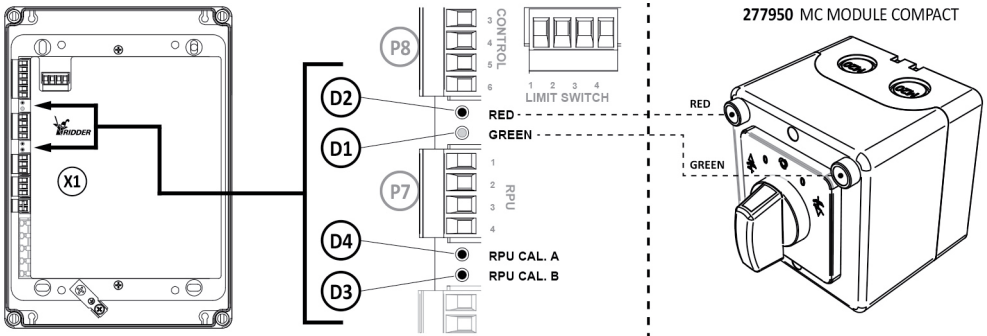

## 6.2 Safety functions and stop features

The RMC400 offers the following safety functions and stop features.

1. Protection against a change of phases of the RMC400 power supply by using phase detection, in order to ensure the right rotational direction of the motor gearbox.
2. To observe a delay time when the direction of rotation is directly reversed.
3. Protection against thermal overload using a Motor Protection Circuit Breaker (MPCB) and/or an eventual integrated PTC thermistor in the electric motor.
4. Stopping when the safety switch is tripped in which manually or automatic control in the opposite rotational direction remains possible.
5. Display of error messages by means of 4 LEDs on the control board (X1).
6. Feedback of error messages by means of an alarm contact (fault contact).



## 6.3 Operation

Explanation of the operating functions with a connected Ridder manual control (X2) (277950) and an automatic control system (X7) (ACS). Always consult the accompanying information and manuals of the applied automatic control system (ACS) and of an eventual different manual control (MC).

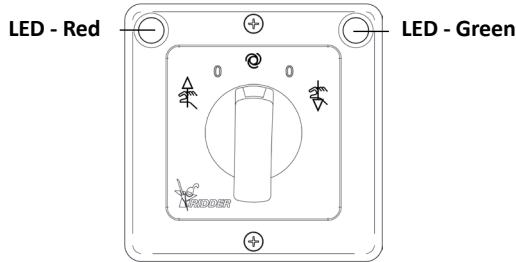



Before using manual control check if the **green LED** on the manual control (and D1 on the control board (X1)) lights up **continuously**.

**Blink code 1.1** means: No malfunctions, the RMC400 is functioning normally. See §9.2.

The switch (X2) with 5 positions offers the following 4 functions.

### Function 1 to 4:

1. Manually control of the system in direction A or B. This is independent from an eventually present automatic 24 V AC/DC control signal (ACS).
2. Putting in Automatic mode of the system, to enable responding to an eventually present automatic 24 V AC/DC control signal (ACS).
3. Manually stopping of the system by putting the switch in position "0".
4. Resetting of error messages in the RMC400 by putting the switch in position "0".

Function	Description	
1	Direction A	
3	Electric motor is not actuated by the manual control.	0
4	Reset position after a malfunction.	0
2	<b>Automatic mode</b> , the RMC400 responds to external actuation from an automatic control system.	
3	Electric motor is not actuated by the manual control.	0
4	Reset position after a malfunction.	0
1	Direction B	



**Control signals from an automatic control system (ACS) are only processed, if the manual control (X2) is in Automatic mode.**



**Automatic mode is only working, if an automatic control signal (ACS) is offered.**

## 7.1 Commissioning

After the RMC400 is installed and connected, the switching sense of the limit switch (X4) must be checked. This is followed by checking if the direction of automatic and manual control correspond with the expected moving direction of the driven system.

§7.2 Checking: Switching sense limit switch (RSU/RLS).

§7.3 Checking: Direction Automatic Control (ACS).

§7.4 Checking: Direction Manual Control (MC).



**When operating the RMC400 do not exceed the limit positions of the driven system, to avoid damage or injury!**



**BEFORE the driven system may be put into operation, the installer must always ensure that the limit switch has been adjusted correctly.**

Consult the product manual on [www.ridder.com](http://www.ridder.com) of the applied Ridder motor gearbox for setting of the end positions.

## 7.2 Checking: Switching sense Limit Switch (RSU/RLS)

1. Run the motor gearbox (X3) in a direction which can cause no damage to the system driven using the manual control (X2).
2. Check if the motor gearbox is rotating in the right direction for the duty switch to switch off the motor.  
**CORRECT** - Go to step 5.  
**NOT CORRECT** - Switch off the power. Go to step 3.
3. Swap the wires on connections 2 and 3 of connector P9.

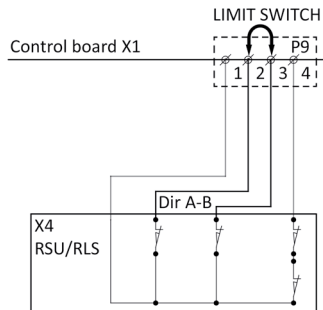

4. Switch on the power. Go to step 1.
5. You have completed checking the switching sense.

### 7.3 Checking: Direction Automatic Control (ACS)

1. Put the switch of the manual control (X2) in “Automatic mode”. 
2. Run the motor gearbox (X3) in a direction which can cause no damage to the system driven using the automatic control (ACS).
3. Check if the direction of the automatic control (ACS) corresponds with the expected moving direction of the driven system.

**CORRECT**- Go to step 6.

**NOT CORRECT** - Switch off the power. Go to step 4.

4. Swap the wires on connections 1 and 3 of connector P6.

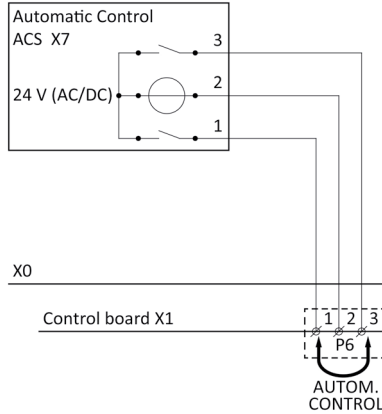

5. Switch on the power. Go to step 1.
6. You have completed checking the rotational direction of the automatic control.

## 7.4 Checking: Direction Manual Control (MC)

1. Run the motor gearbox (X3) in a direction which can cause no damage to the system driven using the manual control (X2).
2. Check if the symbols on the manual control (X2) correspond with the expected moving direction of the driven system.



**CORRECT** - Go to step 5.

**NOT CORRECT** - Switch off the power. Go to step 3.

3. Swap the wires on connections 2 and 4 of connector P8.

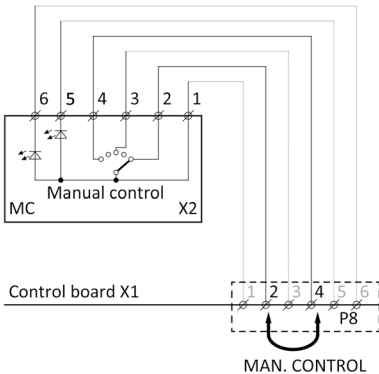

P8	Manual control (X2)
1	24 V DC
2	<b>Direction A</b>
3	Auto
4	<b>Direction B</b>
5	LED red (D2)
6	LED green (D1)

4. Switch on the power. Go to step 1.
5. You have completed checking the rotational direction of the manual control.

## 8.1 Maintenance

The RMC400 is basically maintenance-free. It is however recommended to regularly check the following points while the RMC400 is in use:

- Mechanical conditions such as fastening, connectors, connection terminals etc.;
- RMC400 and LEDs are still in sight and easy accessible in case possible malfunctions might occur.
- Possible malfunctions displayed by the LEDs.

Inspection- and maintenance activities are only allowed for qualified staff.

## 9.1 Troubleshooting

This section describes possible problems and their solutions. If you encounter a problem and/or solution not listed below, please contact your supplier or the manufacturer.

### **Problem 1**      **No supply voltage**

Observation 1      The LEDs D1 and D2 are both off (blink code 1.2).

**Cause 1**              Power supply is externally disconnected.

Solution 1             Connect power supply.

**Cause 2**              No voltage on the control board.

Solution 2             Check the supply voltage with a multimeter on the connections P1 of the control board (X1).

### **Problem 2**      **Electric motor thermally shut-down**

Observation 2      The LEDs D1 and D2 both light up continuously during and after a shut-down of the motor of at least 2 minutes (blink code 1.3).

**Cause 1**              If the temperature in the electric motor becomes higher than 150 °C the system will be thermally shut-down.

Solution 1             Every 2 minutes the RMC400 will check the motor temperature. After cooling down of the motor it will start-up again automatically. The error message remains visible using the LEDs until the RMC400 is reset by putting the manual control switch in "0" position. When this occurs multiple times or if the error does not reset, please contact the supplier.

### **Problem 3**      **Electric motor in safety stop**

Observation 3      The red LED (D2) is blinking while the green LED (D1) lights up continuously (blink code 1.4).

**Cause 1**              The duty switch is possibly not disconnected. The electric motor subsequently runs into the safety switch.

Solution 1             Due to phase detection the RMC400 is able to run backwards from the safety switch after receiving a control signal in opposite direction. This is possible with both a manual- or an automatic control signal. The error message remains visible using the LEDs until the RMC400 is reset by putting the manual control switch in "0" position. When this occurs multiple times or if the error does not reset, please contact the supplier.

### **Problem 4**      **Phase failure**

Observation 4      The red LED (D2) blinks while the green LED (D1) is off (blink code 1.5).

**Cause 1**              A phase failure is detected.

Solution 1             Make sure all phases are mounted correctly and also have a proper connection with the connection terminals.

## 9.2 Blink codes

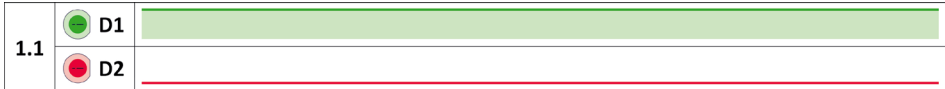

**Motor normal operation:** The RMC400 motor control unit is functioning normally.



**No supply voltage:** RMC400 is receiving no supply voltage.

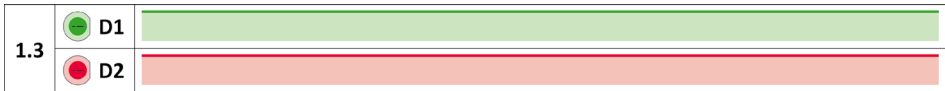

**Motor thermally shut-down:** Above 150 °C the RMC400 will shut-down the motor.

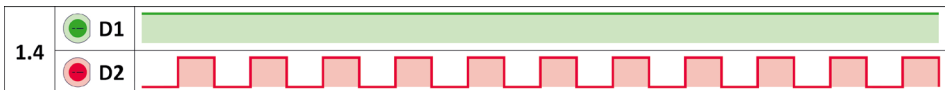

**Motor in safety stop:** The duty switch is possibly not disconnected causing the motor to run into the safety switch.

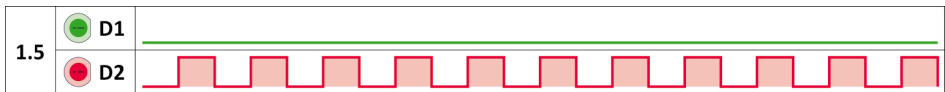

**Phase failure:** A phase failure is occurred in the system.

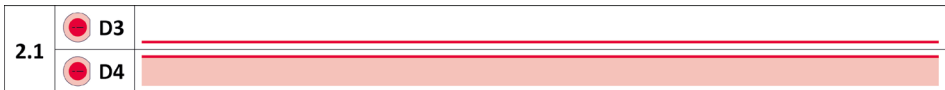

**Reference monitoring:** The reference-input must be connected to **connector 2** of P7.

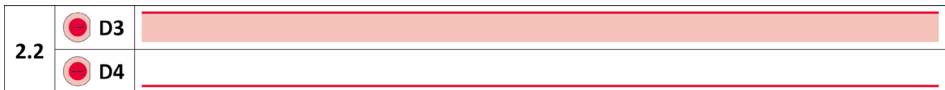

**Reference monitoring:** The reference-input must be connected to **connector 3** of P7.

### 9.3 Technical support

---

For Technical Support please contact your local After Sales contact person. You will find your local After Sales contact person via our website [www.ridder.com](http://www.ridder.com).

### 10.1 Waste disposal

---

End of life products from Ridder Drive Systems must be disposed according to local laws and/ or regulations.

### 10.2 Decommissioning and removal

---

Decommissioning and removal may only be carried out by qualified personnel.

