

Product Manual

Ridder RW45 Motor Gearbox 1-phase (3-wire)

265056EN - V03 - 2016.04

Ridder Drive Systems

Lorentzstraat 36-38 3846 AX Harderwijk
P.O. Box 360 3840 AJ Harderwijk
the Netherlands

T +31 (0)341 416 854 F +31 (0)341 416 611
I www.ridder.com E info@ridder.com



TABLE OF CONTENTS

1. GUIDELINES, STANDARDS AND CONDITIONS	
1.1 Applicable guidelines and standards	3
1.2 Qualified personnel	3
1.3 Warning regarding discouraged use	3
1.4 Warranty provisions	3
2. SYMBOLS, WARNINGS AND SAFETY INSTRUCTIONS	
2.1 Explanation of warnings (ISO 3864-2)	3
3. PRODUCT DETAILS	
3.1 Description	4
3.2 Application	4
3.3 Dimensions	5
3.4 Technical specifications	5
3.5 Identification	6
4. MOUNTING INSTRUCTIONS	
4.1 Special tools and equipment	7
4.2 Mounting positions	7
4.3 Mounting	7
5. CONNECTION INSTRUCTIONS	
5.1 Connection and operation - abbreviations	8
5.2 Electrical material	8
5.3 Connections: Protection	8
5.4 Diagram: 1-phase (3-wire) - RLS control circuit connection	9
5.5 Diagram: 1-phase (3-wire) - RLS motor current connection	10
6. USER INSTRUCTIONS	
6.1 Usage - Conditions and starting points	11
6.2 Direction of rotation RW45 motor gearbox	11
6.3 Operation	12
7. COMMISSIONING INSTRUCTIONS	
7.1 Commissioning - Conditions and starting points	12
7.2 RLS RW-4A limit switch system	12
7.3 Setting the RLS RW-4A limit switch system	13
8. MAINTENANCE INSTRUCTIONS	
8.1 Maintenance	14
9. SERVICE	
9.1 Troubleshooting	15
9.2 Technical support	15
10. ENVIRONMENT	
10.1 Disposal	15
10.2 Decommissioning and removal	15

1. GUIDELINES, STANDARDS AND CONDITIONS

1.1 Applicable guidelines and standards

The Ridder RW45 Motor Gearbox complies with the provisions of the following European guidelines:

Machinery Directive 2006/42/EC | Low Voltage Directive 2006/95/EC

The following harmonized standards (or parts of these standards) have been applied:

NEN-EN-ISO 12100:2010 | NEN-EN-IEC 60204-1 |

NEN 82079-1 (62079: 2001) | NEN5509 | ISO 3864-2

This product may only be put into operation if it has been determined that the system in which the product will be installed complies with the requirements of the applicable standards and guidelines.

1.2 Qualified personnel

This product manual contains important information for installers on how to connect and commission a RW45 motor gearbox. Before proceeding with the work, please read this product manual and instructions carefully. All work must be carried out by qualified and skilled mechanical and / or electrical installers in a safe and responsible manner.

1.3 Warning regarding discouraged use

The following conditions apply when using the RW45.

- The construction of the RW45 may **not** be modified or changed.
- The applicable regulations and guidelines (e.g. CE) **must** be observed.
- The RW45 may **not** be used to lift or move people.
- Do **not** exceed the maximum duty cycle of the RW45.

See §3.2 for a description of the RW45's intended use.



1.4 Warranty provisions

For the warranty period and conditions, please see the 'Conditions' section on our website at www.ridder.com, or in the Ridder catalogue.

2. SYMBOLS, WARNINGS AND SAFETY INSTRUCTIONS

2.1 Explanation of warnings (ISO 3864-2)

This product manual contains tips, notes and warnings of varying degrees of importance. The following list explains what they mean.

	Suggestion to perform an operation more effective.
	May result in damage or problems if an action is performed incorrectly.



May result in minor injury if the hazard is not avoided.



Significant injury, possible death, if the hazard is not avoided.

3. PRODUCT DETAILS

3.1 Description

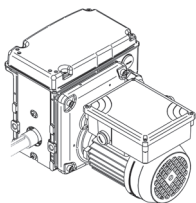

The RW45 motor gearboxes are enclosed in a housing with a sealed limit switch system. The RW45 motor gearboxes are designed to operate at ambient temperatures between 0 and 40°C. The RW45 motor gearbox is equipped with a self-braking worm wheel transmission to brake the drive shaft when the drive unit stops.

The RW45 motor gearboxes feature the RLS linear limit switch system with duty and safety switches. The switching range of the limit switch system equates to 55 or 97 revolutions of the drive shaft. The electric motor is thermally protected using a PTO switch. The optional RPU Positioning Unit monitors the positions of a drive system and transmits this data back to a computer. This position feedback can also be achieved using an installation set with a potentiometer.

- RW45: Fitted with 12-tooth 1/2"x5/16" zinc-plated sprocket for chain couplings. Option for 16-tooth 1/2"x5/16" sprockets to compensate for larger angle differences (up to 6°).
- RW45L: Equipped with a one-sided output shaft for mounting a cable drum or belt drum.
- RW45TRA: Equipped with a one-sided output shaft for mounting a TRA520 rack drive unit.
- RW45D : Equipped with a continuous worm shaft and fitted with 12-tooth 1/2"x5/16" zinc-plated sprocket for chain couplings.

The RW45 motor gearboxes are finished with a graphite grey powder coating and are supplied including fixing bolts and spring washers.

3.2 Application

Intensive Livestock and Crop Storage:

- The RW45 and RW45D motor gearboxes are drive units for driving ventilation and hoisting systems in livestock houses.
- The RW45L motor gearboxes equipped with a cable drum or belt drum are drive units for hoisting feeding and drinking lines, and opening air inlets in livestock houses.
- The RW45TRA motor gearboxes with a TRA520 rack drive are drive units for driving ventilation and hoisting systems in livestock houses.

Horticulture:

- The RW45 motor gearboxes are drive units for driving ventilation and screen systems in greenhouses.
- The RW45TRA motor gearboxes with a TRA520 rack drive are drive units for driving ventilation systems in greenhouses.

3.3 Dimensions

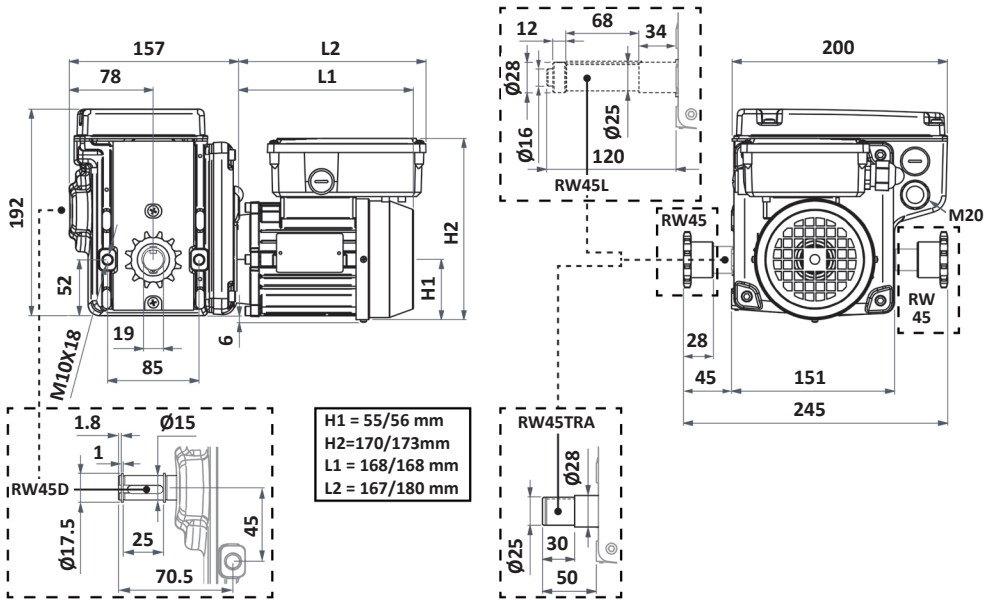

3.4 Technical specifications

Mechanical

Torque	120, 90 of 60 Nm
Speed (revolutions per minute)	50 Hz: 1 - 2 - 3 - 5 rpm 60 Hz: 1.2 - 2.4 - 3.6 - 6.0 rpm
Limit switch range	55 or 97 revolutions (drive shaft)
Drive unit	Self-braking
Manual drive	Enabled by means of a hexagon socket in electric motor shaft.
Dimensions (WxHxD)	Max: 372 x 198 x 320 mm Min: 325 x 197 x 245 mm
Weight	16 - 16.5 kg

Electrical

Supply voltage	115 V AC - 60 Hz (1-phase), 230 V AC - 50/60 Hz (1-phase)
Maximum current	115 V: 2.5 A (60 Hz) 230 V: 1.0 A (50 Hz) 1.1 A (60 Hz)
Power	115 V: 0.09 kW (60 Hz) 230 V: 0.09/0.11 kW (50/60 Hz)

Thermal protection	Up to 140 C° (284 °F) using a PTO
Duty Cycle	Suitable for intermittent duty, duty class s3-35%, up to 25 minutes
Cable gland (2x)	M20x1.5 mm (IP68)

Environment

Protection rating	IP55
Ambient temperature	0-40°C (32-104°F)

3.5 Identification

EXAMPLE

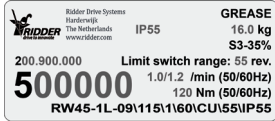

This product manual applies exclusively to:

- Ridder RW45 Motor Gearbox **1-phase 3-wire**.
- Serial numbers from 200.900.000.
- Item numbers from 500000.

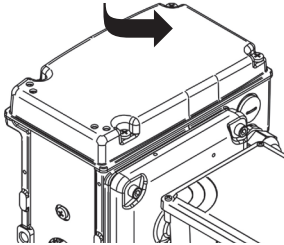

Identification can be obtained from the sticker on the location shown. See example of the sticker and the following explanation on how to read the information. For more information on item numbers and models see the Ridder catalogue or website www.ridder.com.

RW45-1L-09\115\1\60\CU\55\IP55	<ul style="list-style-type: none"> --- IP55: Protection class 55: Limit switch range motor gearbox Alternatives: 97 U: UL approval C: CSA approval 60: Mains frequency 60 Hz Left out if 50 Hz 1: 1-phase mains voltage 115: Mains voltage 115 V Alternatives: 230 09: Motor power in dW --- L: Model with winch shaft --- TRA: Model for built-on rack unit --- D: Model with continuous worm shaft 1: Number of revolutions drive shaft at 50 Hz in rpm Alternatives: 2/3/5 120, 90 or 60: Torque RW motor gearbox in Nm RW45: General designation Ridder RW45 motor gearboxes 	<p>↓ Left out of product identification, if not applicable.</p>

4. MOUNTING INSTRUCTIONS

4.1 Special tools and equipment

For mounting and connecting an RW45 motor gearbox no special tools or equipment are needed.



ATTENTION

Make sure that you apply the correct equipment and tools.

4.2 Mounting positions

Please observe the following mounting positions when installing the RW45 motor gearbox.

$315^\circ \leq \alpha \leq 180^\circ$ ✓ $180^\circ < \alpha < 315^\circ$ ✗

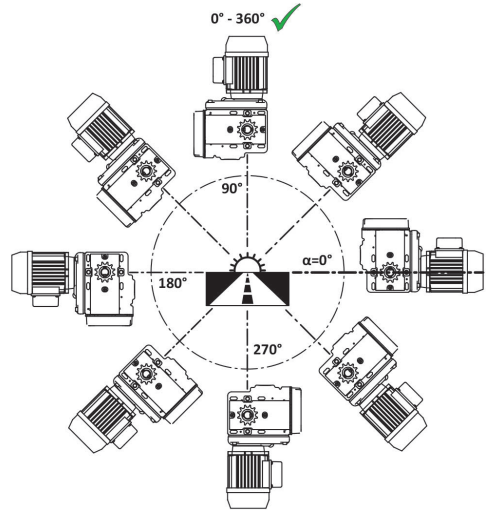
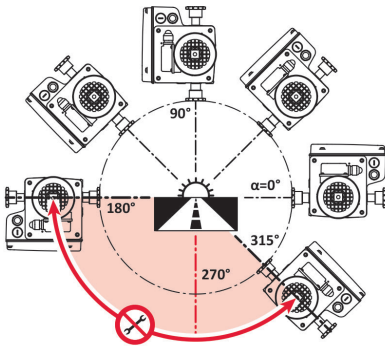

4.3 Mounting

- The RW45 motor gearboxes (with grease lubricant) may only be mounted according to the described mounting positions.
- Depending on the application, mounting plates are available in various sizes. See the Ridder catalogue or website www.ridder.com for more information.
- Make use of the two (2) supplied bolts M10x22 for mounting a RW45 motor gearbox to a structure (mounting plate).
- Make sure that the structure (mounting plate) is definitely strong enough for handling the forces and drive torques of the RW45 motor gearbox.
- When mounting the RW45, ensure that the cover and the motor connections remain easily accessible, so you will have no trouble connecting and adjusting the motor gearbox.

5. CONNECTION INSTRUCTIONS

5.1 Connection and operation - abbreviations

Symbol	Description	Symbol	Description
a, b	Adjusting screw a, b (RLS)	P22/1	Auxiliary contact K22
A, B	End position A, B	P71, P72	Automatic control contacts (ACS)
	Direction of rotation A, B	PE	Protective earth
ACS	Automatic control system	PTO	Protection Thermal Overload Switch
EM, M	Electric motor, Motor	Q41	MPCB
F1	Fuse	Q41/1	Auxiliary contact Q41
L1	Voltage source, Phase-1	RLS	Ridder Limit Switch
N	Neutral wire	S11	Manual switch (bridging safety circuit)
K11	Auxiliary relay (safety switches)		
K11/1	Auxiliary contact K11	S11, S12	Duty switch RLS
K11/2	Auxiliary contact K11	S21, S22	Safety switch RLS
K21, K22	Reversing relay for direction of rotation	S111	Manual switch
		U1	Safety transformer (EN 61558)
MPCB	Motor Protection Circuit Breaker	U1, V1, W1	Motor connection
P21/1	Auxiliary contact K21		

5.2 Electrical material

Use only a conductor diameter of minimal 1.5 mm² for the cables in the wiring diagrams. Depending on the applied components, electrical material and cable lengths etc., a different conductor diameter may be required.



Please use only suitable components and electrical material. Please consult the information of the components and electrical material.

5.3 Connections: Protection

The following conditions apply to the wiring diagrams in this manual.

- The installer makes sure to apply a motor protection circuit breaker (MPCB) and other necessary protections.
- Not displayed protections must be included in the wiring diagrams by the installer.

The following warnings must always be observed.



The Motor Protection Circuit Breaker (Q41) must be set to the value of the nominal current of the electric motor by the installer.



Always make sure if the applied protections are in compliance to the, local or national, laws and regulations of the country!

5.4 Diagram: 1-phase (3-wire) - RLS control circuit connection

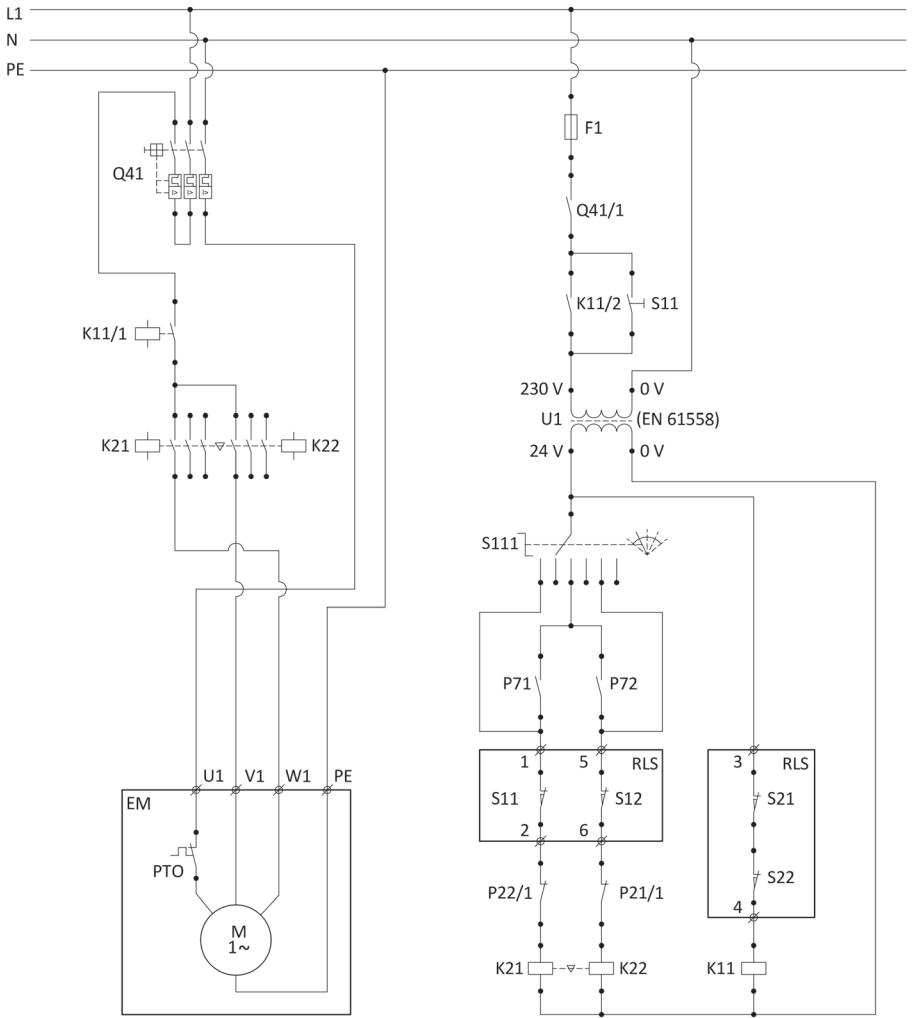

CAUTION

RW motor gearboxes with 1-phase electric motors may not be connected in parallel!



TIP

To reverse direction of rotation of RW motor gearbox:
Swap connections V1 and W1 on electric motor connection strip.



TIP

To reverse switching sense of RLS limit switch system:
Swap connections 1 and 5 in connection blocks of RLS limit switch.



Ridder Drive Systems

T +31 (0)341 416 854 F +31 (0)341 416 611 | www.ridder.com

5.5 Diagram: 1-phase (3-wire) - RLS motor current connection

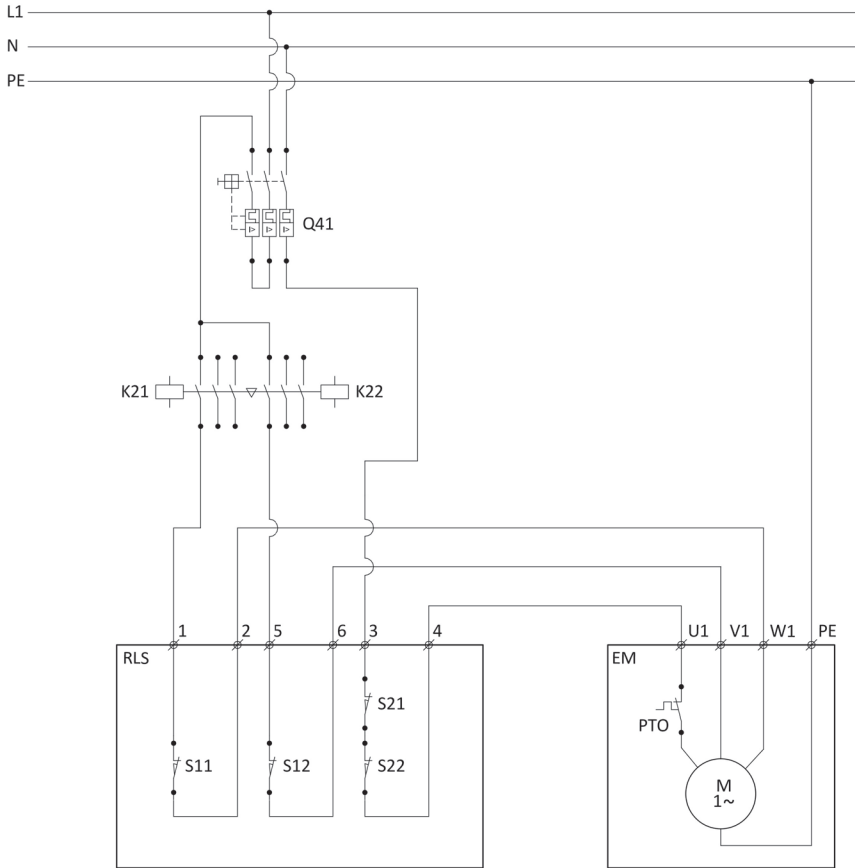

CAUTION

RW motor gearboxes with 1-phase electric motors may not be connected in parallel!



TIP

To reverse direction of rotation of RW motor gearbox:
Swap connections V1 and W1 on electric motor connection strip.



TIP

To reverse switching sense of RLS limit switch system:
Swap connections 1 and 5 in connection blocks of RLS limit switch.

6. USER INSTRUCTIONS

6.1 Usage - Conditions and starting points

The following conditions and starting points apply when using the RW45.

Thermal protection

The system is thermally protected using a PTO switch which is integrated in the motor. If the motor temperature becomes higher than 140 C° the system will be shut-down. After cooling down of the motor below 140 C° it will start-up again automatically.



WARNING

**Motor may start up and shut down automatically without warning!
Power supply however will always remain present!
DISCONNECT POWER SUPPLY BEFORE STARTING ACTIVITIES.**



CAUTION

Motor can reach temperatures higher than 140 C°. If necessary take protective measures to prevent injuries!

Power Supply



WARNING

Disconnect the power supply when working on or maintaining a RW45 motor gearbox or the system driven.

Delay time



CAUTION

**Delay time when reversing the direction of rotation:
When reversing the direction of rotation a delay time of approximately 2 seconds must be observed.**

6.2 Direction of rotation RW45 motor gearbox

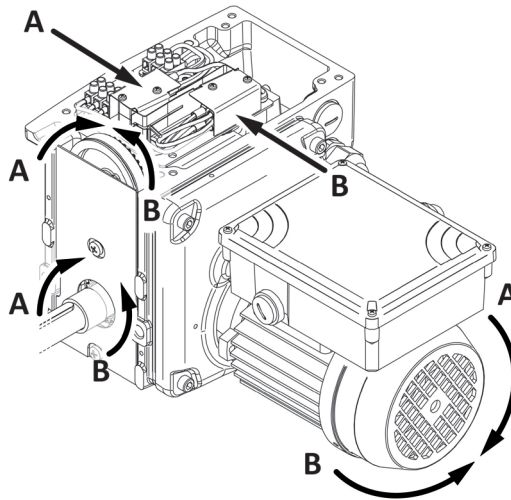

6.3 Operation

An RW motor gearbox can be operated by an intelligent **control unit** (Ridder MotorControl RMC). Operation is also possible in combination with one or both of the following control components:

- Automatic control system (ACS);
- Manual control (MC).

See the Ridder catalogue or website www.ridder.com for more information. Always consult the manual(s) of the control components used.

7. COMMISSIONING INSTRUCTIONS

7.1 Commissioning - Conditions and starting points

To commission an RW45, it is important to have an understanding of the operation and features of the RLS limit switch system described in §7.2. After the RW45 has been mounted and connected, you need to set the end positions of the RLS limit switch system.

§7.2 RLS RW-4A limit switch system.

§7.3 Setting the RLS RW-4A limit switch system

7.2 RLS RW-4A limit switch system

1. threaded shaft
2. knurled nut
3. adjusting ring
4. connection nut
5. switch spring
6. stop
7. hex wrench 2 mm
- a. adjusting screw
- b. adjusting screw
- S11. duty switch
- S12. duty switch
- S21. safety switch
- S22. safety switch

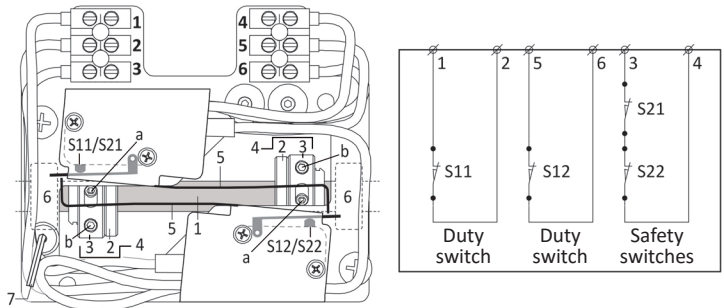

The following information explains the working and setting of the limit switch system.

Current (I) in the switching circuit at 24 V AC:

This must have a value between 45 mA and 130 mA (24 V AC).

Switching power of the limit switch at 115/230 V AC:

A RW45 motor gearbox with a single phase electric motor of:

- max. **0,09 kW** at 115 V AC - 60 Hz or 230 V AC - 50 Hz
- max. **0,11 kW** at 230 V AC - 60 Hz

Ridder RLS RW-4A limit switch system (1-phase, 3-wire)

The Ridder RLS limit switch system is a linear switch system, specifically designed for use in the RW motor gearboxes. The limit switch system is driven by the output shaft of the motor gearbox, via a secondary transmission. A number of revolutions of the output shaft can be set between the end positions. The maximum switching range of the limit switch system equates to 55 or 97 revolutions of the drive shaft (RW45).

Delivery

A Ridder motor gearbox with RLS limit switch system is delivered with connection nuts (4) whose adjusting rings (3) still have to be fastened. This means that the drive can turn freely in both directions. This also avoids the possibility of causing damage to the limit switch system (when it has not yet been connected), should any (preset) limiting positions be exceeded during electrical or manual operation of the motor.

How it works

The transmission drives the threaded shaft (1) of the Ridder RLS limit switch system. When running, the connection nuts (4) will move along the threaded shaft (1) as it rotates. One adjusting screw (a) rests against the switch spring (5). When an end position is reached, the connection nut (4) runs against the stop (6) and will then rotate with the threaded shaft (1). This deflects the switch spring (5), and a duty switch (S11 or S12) will be tripped which results in stopping the motor gearbox. Should a duty switch fail, then a safety switch (S21 or S22) will be tripped by the switch spring (5). This also results in stopping the motor gearbox which prevents consequential damage to the driven system.

Connection

When connecting the Ridder RLS limit switch system, please refer to the wiring diagram (§5.4/5.5).

7.3 Setting the RLS RW-4A limit switch system

The following conditions apply to “setting” the end positions:

- The direction of rotation of the motor gearbox is already checked after connection in §5.4-§6.3.
- The switching sense of the RLS is already checked after connection in §5.4-§6.3.
- Setting sequence: You can set the end positions from A to B or from B to A.

► Description

- Rotate the output shaft (manual or electrical) and bring the system to an end position (A or B).
- Determine which duty switch (S11 or S12) should be tripped.

1

Remark: The switching sense of the RLS limit switch system can be reversed by swapping connections 1 and 5 in the connection blocks.

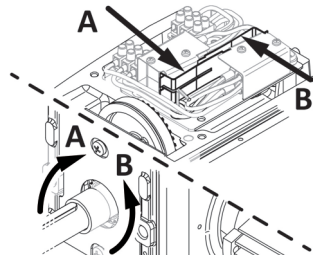

When operating the RW45 motor gearbox do not exceed the limit positions of the driven system to avoid damage or injury!

On the corresponding side (A or B):

2

- Manually turn the knurled nut (2), on the threaded shaft (1), towards the stop (6). The connection nut (4) will move in a straight line along the threaded shaft (1).
- Turn the knurled nut (2) "hand tight" against the stop (6).

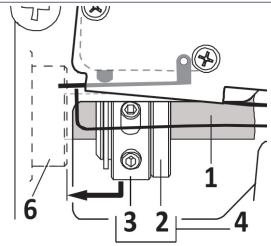

3

Turn the adjusting ring (3) over the knurled nut (2) until the duty switch S (S11 or S12) is activated by the adjusting screw (a) and switch spring (5).

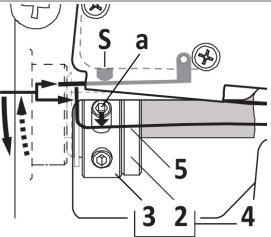

4

Lock the adjusting ring (3) in this position on the knurled nut (2) with the adjusting screws (a) and (b) using the hex wrench (7). The adjusting ring (3) can no longer be turned over the knurled nut (2).

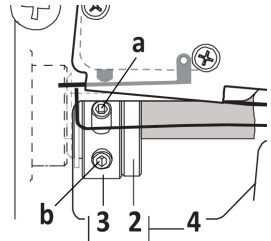

5

In order to set the opposite end position (A or B), repeat steps 1 to 4.



WARNING

Always check the functioning of the limit switch system after setting up both end positions!



CAUTION

Once an RLS limit switch system has been set and the motor gearbox is operated externally (manually), always make certain that the limiting positions set by the limit switch are never exceeded. This can seriously damage the limit switch system, such that the limit switch system no longer functions correctly!

8. MAINTENANCE INSTRUCTIONS

8.1 Maintenance

Although the motor gearbox is essentially maintenance free, it is recommended to regularly check:

- Operation performance and possible **grease** leakage. Inform your installer in case of grease leakage.
- Mechanical conditions (wear and tear, attachments).
- The pre-set end positions (are they still correct for the driven system?).

Inspection and maintenance work may only be carried out by qualified personnel.

9. SERVICE

9.1 Troubleshooting

This section describes possible problems you may encounter and their solutions. If you run into a problem not listed below, please contact your supplier or the manufacturer.

Problem 1 **RW45 is not being driven.**

Observation 1 Electric motor (EM) is running, but RW gearbox output shaft is not rotating.

Cause 1 Electric motor is defective.

Solution 1 Check electric motor (EM) and replace it if defective.

Cause 2 Mechanical defect.

Solution 2 Remove electric motor (EM). Check the key and replace it if defective.
If the key is intact, replace the RW gearbox.

Problem 2 **The direction of rotation of the motor gearbox is not correct.**

Observation 2 The output shaft is rotating in the wrong direction.

Cause 1 Connections on electric motor connection strip are incorrect.

Solution 1 Swap connections V1 and W1 on electric motor connection strip.

Problem 3 **The switching sense of the RLS limit switch system is not correct.**

Observation 3 When running the system to endposition A or B the opposite duty switch is tripped.

Cause 1 Connections in connection blocks of RLS limit switch are incorrect.

Solution 1 Swap connections 1 and 5 in connection blocks of RLS limit switch.

9.2 Technical support

For technical support, please contact your local After Sales contact person. You can find your local After Sales contact person on our website at www.ridder.com.

10. ENVIRONMENT

10.1 Disposal

Products of Ridder Drive Systems should be disposed of after their lifespan in accordance with the applicable national and/or local regulations.

10.2 Decommissioning and removal

Decommissioning and removal may only be carried out by qualified personnel.

