

# Installation Manual

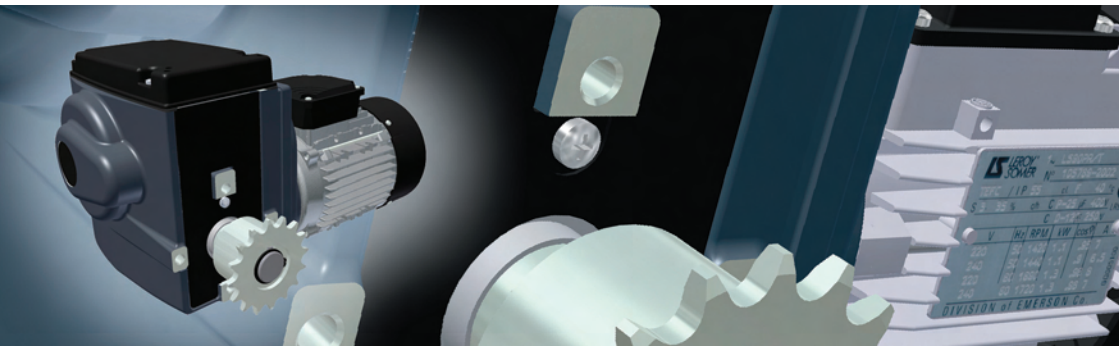

## RW240/400/600 Motor Gearbox

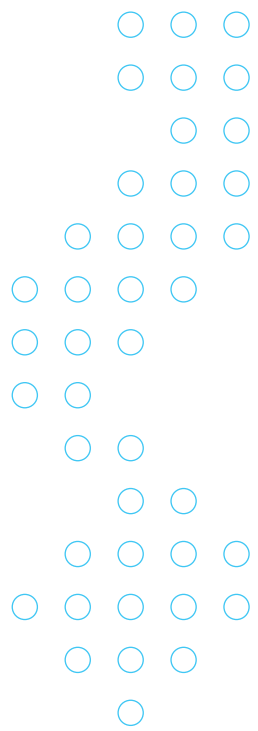

### Ridder Drive Systems

Lorentzstraat 36-38 ◦ 3846 AX Harderwijk  
P.O. Box 360 ◦ 3840 AJ Harderwijk  
The Netherlands

T +31 (0)341 416 854 ◦ F +31 (0)341 416 611  
E [info@ridder.com](mailto:info@ridder.com) ◦ I [www.ridder.com](http://www.ridder.com)

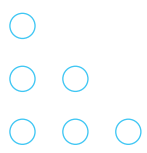

## Index

Installation manual for RW240/400/600 motor gearboxes .....	2
Warnings in this installation manual .....	2
Ridder RW240/400/600 motor gearboxes .....	3
Mounting of RW240/400/600 motor gearbox .....	4
Breather plug RW240/400/600 motor gearbox with oil lubricant .....	4
Mounting positions RW240/400/600 motor gearbox with oil lubricant .....	5
Mounting positions RW240/400/600 motor gearbox with grease lubricant .....	6
Junction diagram symbols .....	7
Junction diagram RW240/400/600 motor gearbox: 3-phase .....	8
Junction diagram RW240/400/600 motor gearbox: 1-phase (3-wire) .....	9
Junction diagram RW240/400/600 motor gearbox: 1-phase (5-wire) .....	10
Adjustment RSU limit switch system .....	11
Directions of rotation RW240/400/600 motor gearboxes .....	12

## Installation manual RW240/400/600 motor gearbox

This installation manual for the Ridder RW240/400/600 motor gearboxes contains basic information for the mechanical and electrical installer. Read this installation manual before installing a Ridder RW240/400/600 motor gearbox. All installation handlings must be carried out safely and correctly by qualified and competent mechanical and electrical installers.

## Warnings in this installation manual

This manual contains tips, observations and warnings. They are divided into a number of gradations. The following shows an overview and description of the meaning of the tip, observation or warning.



A suggestion or advice in respect of carrying out an operation.



Remarks and extra information regarding potential problems arising when an operation is carried out incorrectly.



The product or system can be at risk when an operation is carried out incorrectly.



The user, installer or other persons could suffer physical and/or life threatening injury when an operation is carried out incorrectly.

## Ridder RW240/400/600 motor gearboxes



The RW240/400/600 motor gearboxes are maintenance-free, compact power units for driving ventilation, screening and lifting systems in greenhouses and livestock sheds. All RW240/400/600 motor gearboxes feature a self-braking worm gear transmission. This transmission ensures that the output shaft is braked when the drive unit is stopped. The combination of carefully matched pinion and worm reductions results in a very quiet mechanical transmission.

The RW240/400/600 motor gearboxes feature a patented integrated linear limit switch system with duty and safety switches having excellent switching precision. The maximum switching range of the limit switch system equates to 86 revolutions of the drive shaft. By using a potentiometer with the optional built-in set, it is possible to precisely feed back the positions of a drive system to a (climate) computer.

The RW240/400/600 motor gearboxes are standard finished with a graphite grey powder coating and are supplied including fixing bolts and spring washers.

### RW240/400/600 Motor gearboxes:

- Drive torques of 240Nm, 400Nm or 600Nm at 50 Hz and 60 Hz mains frequencies;
- Rotation speeds of 1 to 5 rpm at 50 HZ, 1.2 to 6 rpm at 60 HZ mains frequency;
- Suitable for intermittent duty, duty class s3-30%, duty cycle maximum 25 minutes;
- Fitted with 16-tooth 5/8"x3/8" zinc-plated sprocket for chain couplings;
- Manual drive enabled by means of a hexagon socket in the electric motor shaft;
- Electric motors are standard tropic-proof and conform to protection class IP55;

### Electric motors for RW240/400/600 motor gearboxes:

- 3-phase euro voltage for use on main voltages of 400V at 50Hz and 480V at 60Hz;
- 3-phase wide voltage electric motors with UL (recognized) and CSA approval mark, for use on mains voltages from 208-415 V at 50 Hz and 60 Hz and 415-480 V at 60 Hz;
- 3-phase electric motors with CSA approval mark, for use on mains voltage of 600 V at 60 Hz;
- 1-phase electric motors for use on mains voltage of 230 V at 50 Hz and 60 Hz;
- 1-phase electric motors with CSA approval mark, for use on mains voltage from 115 V at 60 Hz.



**Do not exceed the maximum duty cycle**



**Do not use the Ridder RW240/400/600 motor gearboxes for transporting / lifting people**



**Disconnect the power supply when working on or maintaining a RW240/400/600 motor gearbox or the system driven**

## Mounting of RW240/400/600 motor gearbox

The RW240/400/600 motor gearboxes (with oil or grease lubricant) may only be mounted according to the described mounting positions. Make use of the three (3) supplied bolts M10x22 for mounting a RW240 or RW400 or RW600 motor gearbox to a structure (mounting plate). Make sure that the structure (mounting plate) is definitely strong enough for handling the forces and drive torques of the RW240 or RW400 or RW600 motor gearbox.

## Breather plug RW240/400/600 motor gearbox with oil lubricant

After mounting of a RW240/400/600 motor gearbox with oil lubricant (oliegevuld), the upmost oil plug has to be replaced by the supplied oil breather plug.

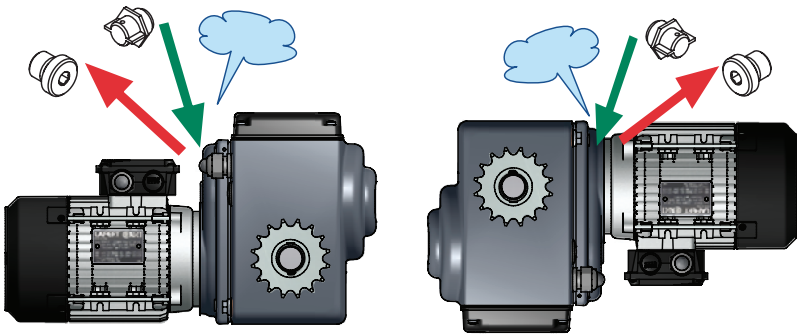

**CAUTION**

Mounting the motor gearbox without the breather plug could lead to oil leakage

# Mounting positions RW240/400/600 motor gearbox with oil lubricant

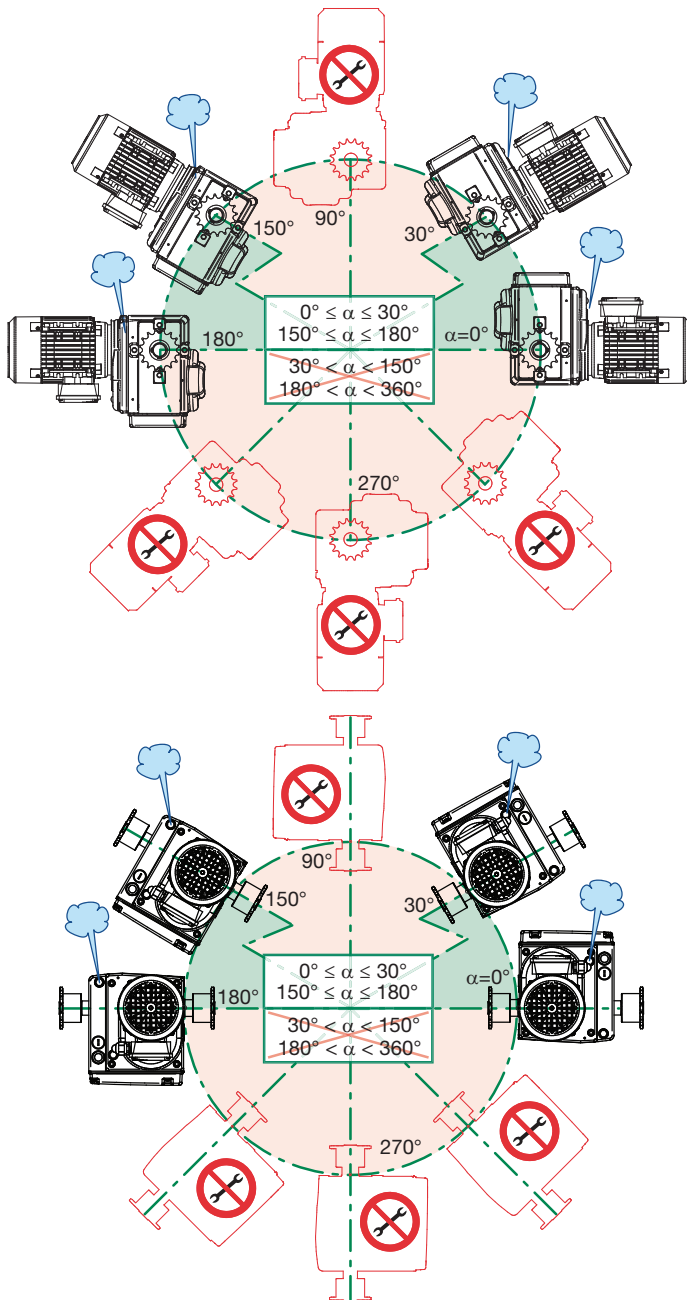

# Mounting positions RW240/400/600 motor gearbox with grease lubricant

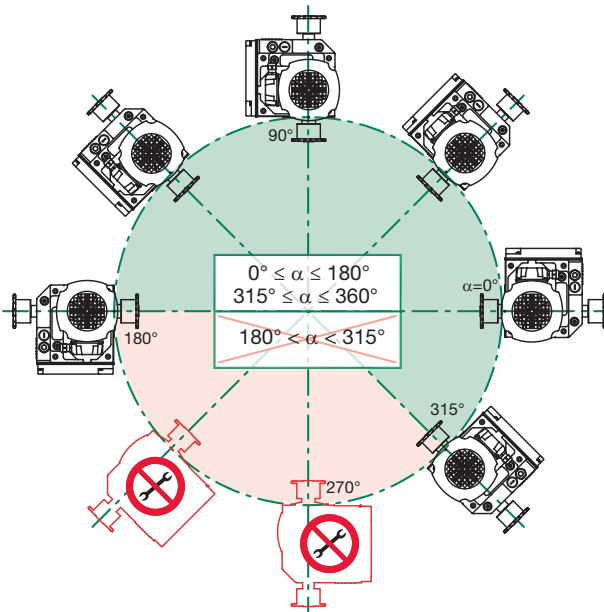
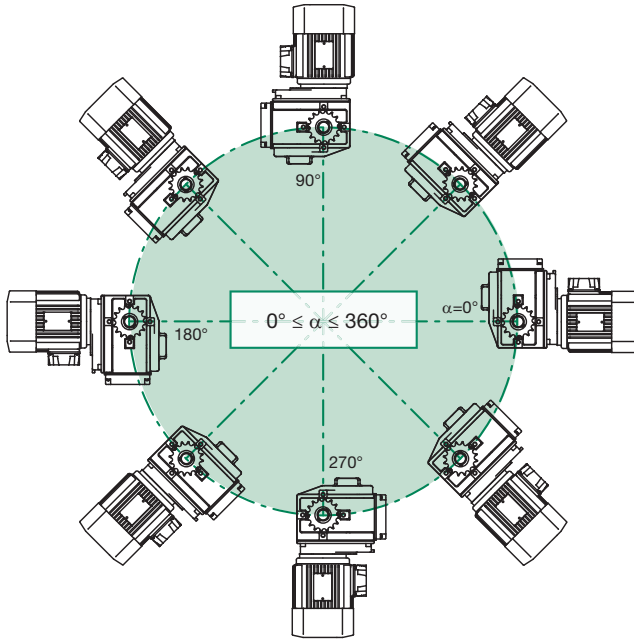

## Junction diagram symbols

Symbol	Description
EM	Electric motor
ES11, ES12	Working switch limit switch system
ES21, ES22	Safety switch limit switch system
F1	Fuse
K11	Safety relays
K21, K22	Direction switching relays
L1, L2, L3	Power lines, power supply
N	Neutral
P21, P22	Electrical interlock
P71, P72	Automatic control
PE	Earth
Q41	Motor safety switch
S11	Manual switch (emergency switch override)
S111	Manual switch
U1	Transformer



### CAUTION

Observe 2 seconds time delay before switching direction of rotation



### CAUTION

Parallel connecting of single phase electric motors is not allowed!

# Junction diagram RW240/400/600 motor gearbox: 3-phase

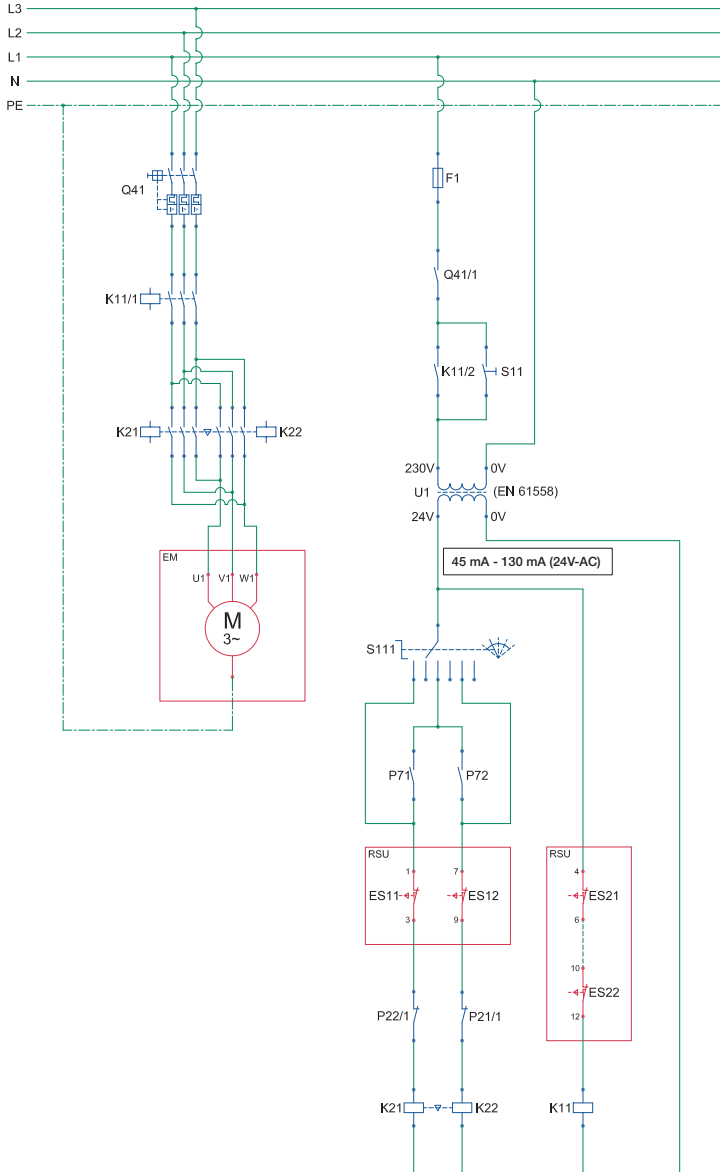

**Changing the direction of rotation electric motor: Swap L1 and L2**  
**Change switching direction of limit switch system: Swap 1 and 7**



# Junction diagram RW240/400/600 motor gearbox: 1-phase (3-wire)

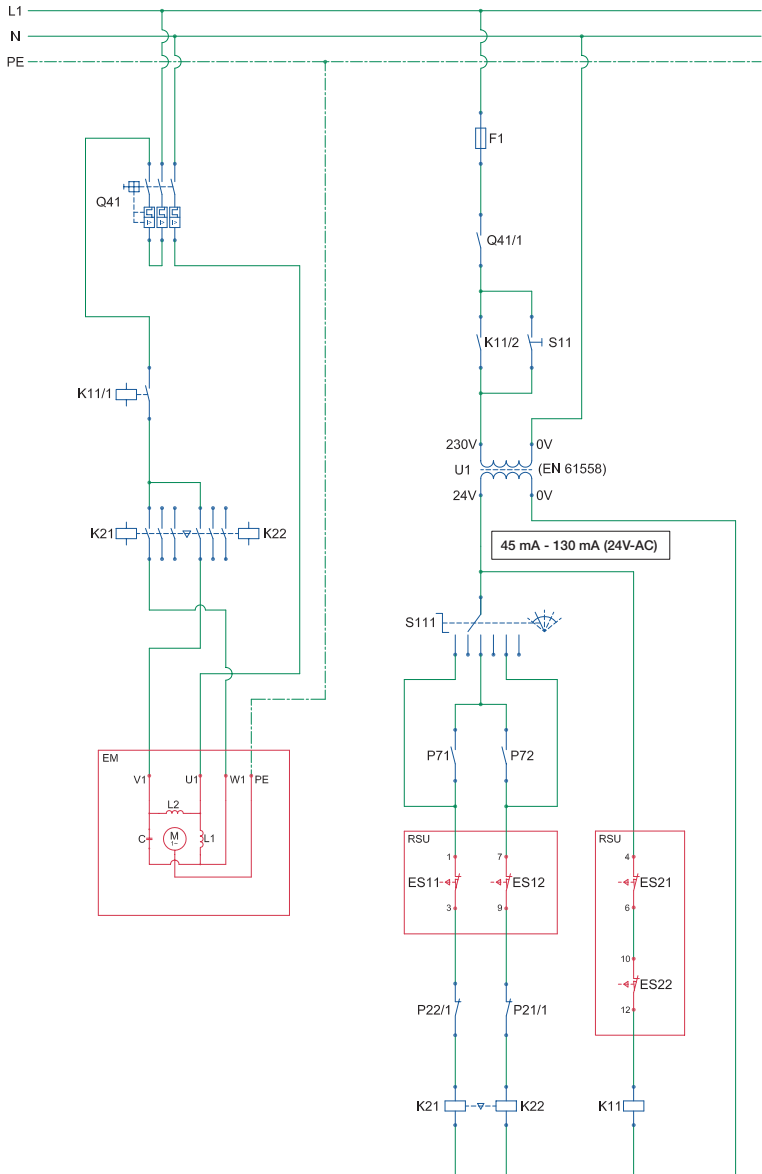

**Changing the direction of rotation electric motor:** Swap V1 and W1  
**Change switching direction of limit switch system:** Swap 1 and 7

# Junction diagram RW240/400/600 motor gearbox: 1-phase (5-wire)

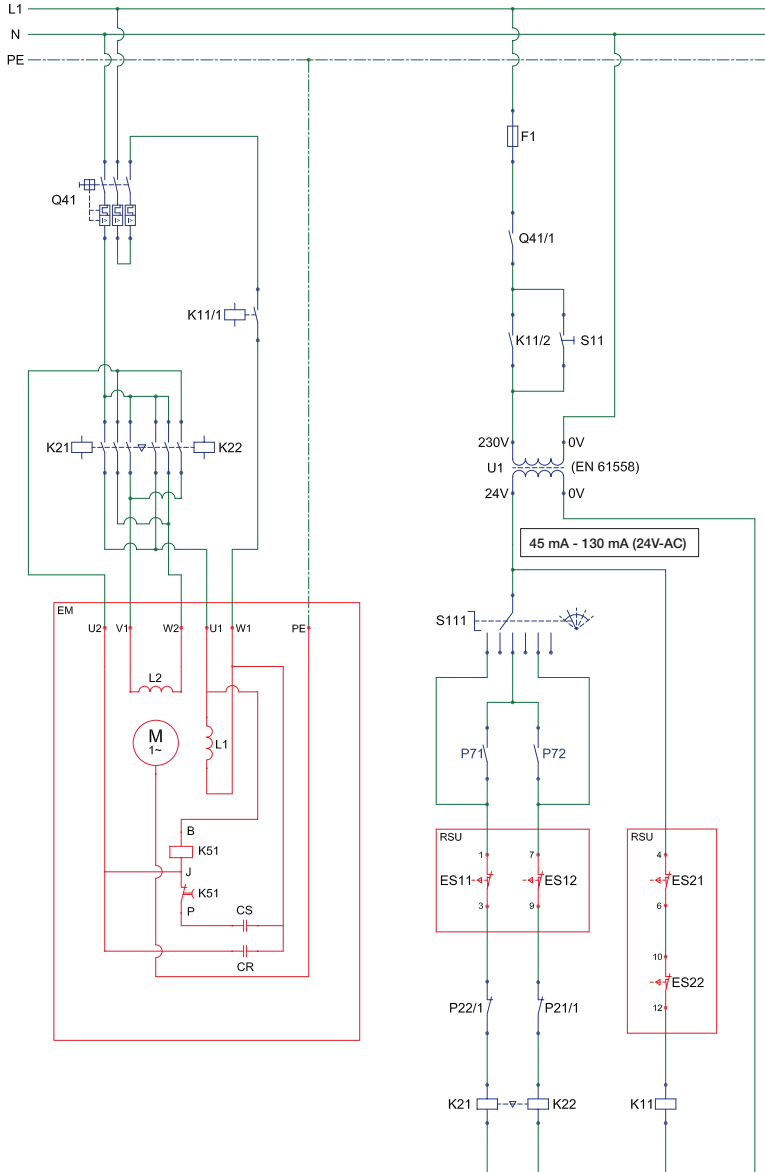

**TIP**

**Changing the direction of rotation electric motor: Swap V1 and W2**  
**Change switching direction of limit switch system: Swap 1 and 7**

## Adjustment RSU limit switch system

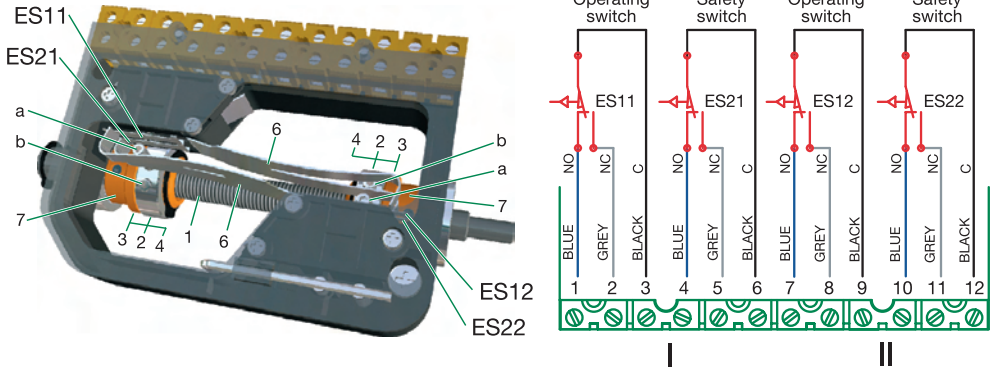

### RSU limit switch system installation

The steps required in order to correctly set the RSU limit switch system of an RW240/400/600 motor gearbox, are described below.

### Current and voltage range

The contacts in the switches of the Ridder RSU limit switch system, are capable of switching the following currents:

- 24 V-AC, currents from 45 mA to 130 mA;
- 230 V, currents up to 1 A.

### Ridder RSU limit switch system

The Ridder RSU limit switch system is a linear switch system, specifically designed for use in the RW motor gearboxes. The limit switch system is driven by the output shaft of the motor gearbox, via a secondary transmission. Depending on the type of motor gearbox, a number of revolutions of the output shaft can be set, between a starting and ending position. For the RW240/400/600 motor gearboxes this will be a maximum of 86 revolutions of the output shaft.

### Delivery

A Ridder motor gearbox with RSU limit switch system is delivered with switch followers (4) whose adjustment rings (3) still have to be fastened. This means that the drive can turn freely in both directions. This also avoids the possibility of causing damage to the limit switch system (when it has not yet been connected), should any (preset) limiting positions be exceeded during electrical or manual operation of the motor.

### How it works

This transmission drives the threaded shaft (1) of the Ridder RSU limit switch system, either with a toothed belt, or with a worm and gear combination. When running, the threaded switch followers (4) will move along the threaded shaft as it rotates. One setscrew (a) rests against the switch spring (6). When an end position is reached, the switch follower will strike the stop (7) and will then rotate with the threaded shaft. This deflects the switch spring, and a duty switch (ES11 or ES12) will be tripped. This causes a signal that activates the relay, stopping the motor gearbox. Should a relay or duty switch fail, then a safety switch (ES21 or ES22) will also be tripped by the switch spring. This causes a signal that activates a safety relay, stopping the controller and also thereby the motor gearbox. This prevents consequential damage to the driven system.

## Connection

When connecting the Ridder RSU limit switch system, please refer to the wiring diagrams provided for this purpose.

## Setting

The “start position” and “end position” are set as follows:

- By rotating the output shaft (manually or under power), bring the system to the “start position” or “end position” and determine which duty switch (ES11 or ES12) should be tripped. The switching sense of the RSU limit switch system can be reversed by swapping connections 1 and 7 in the connection block.
- Turn the milled bush (2) on the appropriate side, “hand tight” up to the stop (7). The milled bush can easily be screwed by hand along the threaded shaft (1). The switch follower (4) also moves along the threaded shaft.
- Now rotate the adjustment ring (3) over the milled nut just far enough to trip the duty switch. Then fasten the adjustment ring with setscrews (a and b) firmly on the milled nut. The adjustment ring can no longer be rotated over the milled nut.
- Repeat previous items to adjust the limit switch system for the opposite rotation direction.

This completes the setting of the limit switch system.



**Always check the functioning of the limit switch system after setting up both end positions.**



**When a motor gearbox with an adjusted limit switch system is operated manually, do not exceed the set up end positions. This can lead to mal functioning of the limit switch system and serious damage to the system driven.**

## Directions of rotation RW240/400/600 motor gearboxes

