

---

Models:  
CDU\*  
CDX  
2CDU\*  
2CDX



Instruction and Operation Manual

---



\* NSF/ANSI 61 Annex G listed models: CDU, 2CDU



**EBARA Standard Pump**

EBARA Pumps Americas Corporation

**Instructions and Operation**

**Contents**

Section	Page
Safety Instructions .....	2
General Description .....	2
Installation .....	3
Selection charts .....	4
Specifications .....	5
Sectional view .....	9
Mounting Instructions .....	13
Maintenance .....	14
CDU/CDX Assembly Instructions .....	15
Assembly/Disassembly .....	16
Troubleshooting .....	17

**NOTE:** Only products bearing the NSF Mark on the product, product packaging, and/or documentation shipped with the product are Certified.



**WARNING**

**IMPORTANT SAFETY INSTRUCTIONS  
Rules for Safe Installation and Operation**

1. Read these rules and instructions carefully. Failure to follow them could cause serious bodily injury and/or property damage.
2. Check your local codes before installing. You must comply with their rules
3. For maximum safety, this product should be connected to a grounded circuit equipped with a ground fault interrupter device.
4. Before installing this product, have the electrical circuit checked by an electrician to make sure it is properly grounded.
5. Before installing or servicing your pump, BE CERTAIN pump power source is disconnected.
6. Make sure the line voltage and frequency of the electrical current supply agrees with the motor wiring. If motor is dual voltage type, BE SURE it is wired correctly for your power supply.
7. Complete pump and piping system MUST be protected against below freezing temperature. Failure to do so could cause severe damage and void the warranty.
8. Avoid system pressures that may exceed one and a half times the operating point selected from the pump performance curve.
9. Do not run your pump dry. If it is, there will be damage to the pump seal.

**General Description**

CDU, 2CDU, CDX, 2CDX model pumps may be used for the pumping of clean water and other fluids compatible with 304 stainless steel. These pumps are not to be used for handling dirty water or water with suspended solids, water containing acids, or corrosive liquids, seawater, and flammable or dangerous liquids. Please see pump specifications for fluid temperature ranges. These pumps are not designed to run without water.

2CDU/2CDXU model pumps and CDU/CDXU model pumps are similar in function and construction. The differences between the models include:

- single impeller vs. twin impeller
- flow rate
- heads
- weight
- dimensions.

Please see the technical specifications in this manual for more detailed descriptions.



**Instructions and Operation**

---

**Rules for Safe Installation and Operation**

---

**PACKAGE CONTENTS**

1. Be sure all parts have been furnished and that nothing has been damaged in shipment.
2. The catalog lists all parts included with package. A packing list packed with pump, also lists contents.
3. **OPEN PACKAGES AND MAKE THIS CHECK BEFORE GOING TO JOBSITE.**

**PIPING** – Pipes must line up and not be forced into position by unions. Piping should be independently supported near the pump so that no strain will be placed on the pump casing. Where any noise is objectionable, pump should be insulated from the piping with rubber connections. Always keep pipe size as large as possible and use a minimum of fittings to reduce friction losses.

**SUCTION PIPING** – Suction pipe should be direct and as short as possible. It should be at least one size larger than suction inlet tapping and should have a minimum of elbows and fittings (5 to 6 pipe diameters of straight pipe before inlet is recommended). The piping should be laid out so that it slopes upward to pump without dips or high points so that air pockets are eliminated. The highest point in the suction piping should be the pump inlet except where liquid flows to the pump inlet under pressure.

The suction pipe must be tight and free of air leaks or pump will not operate properly.

**DISCHARGE PIPING** – Discharge piping should never be smaller than pump tapping and should preferably be one size larger. A gate valve should always be installed in discharge line for throttling if capacity is not correct. To protect the pump from water hammer and to prevent backflow, a check valve should be installed in the discharge line between the pump and gate valve.

**ELECTRICAL CONNECTIONS** – Be sure motor wiring is connected for voltage being used. Unit should be connected to a separate circuit. A fused disconnect switch or circuit breaker must be used in this circuit. Wire of sufficient size should be used to keep voltage drop to a maximum of 5%.

Single phase motors have built-in overload protection. Flexible metallic conduit should be used to protect the motor leads.

**PRIMING** – The pump must be primed before starting. The pump casing and suction piping must be filled with water before starting motor. Remove vent plug in top of casing while pouring in priming water. A hand pump or ejector can be used for priming when desired. When water is poured into pump to prime, remove all air before starting motor.

**STARTING** – When the pump is up to operating speed, open the discharge valve to obtain desired capacity or pressure.

**WARNING! DO NOT ALLOW THE PUMP TO RUN WITH THE DISCHARGE VALVE TIGHTLY CLOSED. IF THE PUMP RUNS FOR AN EXTENDED PERIOD OF TIME WITHOUT LIQUID BEING DISCHARGED, THE LIQUID IN THE PUMP CASE CAN GET EXTREMELY HOT CAUSING SEVERE DAMAGE TO THE PUMP AND POSSIBLY CAUSE INJURY TO PEOPLE.**

**ROTATION** – All single phase motors are single rotation and leave factory with proper rotation. Three phase motors should be checked to ensure proper rotation

**FREEZING** – Care should be taken to prevent the pump from freezing during cold weather. It may be necessary, when there is any possibility of this, to drain the pump casing when not in operation. Drain by removing the pipe plug in the bottom of the casing.

**ROTARY SEAL** – PRO STEEL pumps are fitted only with rotary seal. This seal is recommended for LIQUIDS free from abrasives.

**LOCATION OF UNIT** – The pump should be installed as near to the liquid source as is practical so that the static suction head (vertical distance from the center line of the pump to water level) is maximized, and so that a short, direct suction pipe may be used. The capacity of a centrifugal pump is reduced when the unit is operated under a high suction lift. The piping should be as free from turns and bends as possible, as elbows and fittings greatly increase friction loss. Place the unit so that it is readily accessible for service and maintenance and on a solid foundation, which provides a rigid and vibration-free support. Protect the pump against flooding and excess moisture.



**Model CDU, CDX, 2CDU, 2CDX      EBARA End Suction Centrifugal / Two-stage Centrifugal**  
**Instructions and Operation**

**Specifications – CDX**

	Standard	Optional
<b>Size</b>		
Suction	1 1/4" NPT Thread 1 1/2" NPT Thread	
Discharge	1" NPT Thread	
<b>Range of HP</b>	3/4 HP to 3 HP	
<b>Range of Performance</b>		
Capacity	5.5 to 68 GPM at 3600 RPM	
Head	40 to 130 feet at 3600 RPM	
<b>Liquid handled</b>		
Type of liquid	Clean water	
Temperature	Maximum: 140°F (60°C)	
Working pressure	Maximum: 8 PSI	
<b>Materials</b>		
Casing	304 Stainless Steel	
Impeller (closed type)	304 Stainless Steel	
Shaft	303 Stainless Steel	
Bracket	Aluminum	
Shaft Seal	Mechanical Seal Carbon/Ceramic/NBR	Consult factory for additional seal options
<b>Direction of Rotation</b>	Clockwise when viewed from motor end	
<b>Motor</b>		
Type	TEFC/IP55	
Speed	60 Hz, 3600 RPM (2 poles)	
Single Phase	230V	
Three Phase	230/460V	
Motor Protection	Built-in overload protection (single phase)	
Bearing	Sealed Ball Bearing	



**Model CDU, CDX, 2CDU, 2CDX      EBARA End Suction Centrifugal / Two-stage Centrifugal**  
**Instructions and Operation**

**Specifications – CDU**

	Standard	Optional
<b>Size</b> Suction  Discharge	CDU70 – 1¼" NPT thread CDU120 – 1¼" NPT thread CDU200 – 1½" NPT thread 1" NPT thread	
<b>Range of HP</b>	½ HP to 3 HP	
<b>Range of Performance</b> Capacity Head	5.5 to 95 GPM at 3450 RPM 26 to 144 feet at 3450 RPM	
<b>Liquid handled</b> Type of liquid Temperature  Max. working pressure	Water 212 F (100 C)  125 PSI (9 Bar)	Max. 250 F (121 C) with optional high temperature seal
<b>Materials</b> Casing Impeller (closed type) Shaft Bracket Shaft Seal	304L Stainless Steel 304L Stainless Steel Stainless Steel Aluminum Mechanical Seal – Type 21	High temperature version Mild chemical version
<b>Direction of Rotation</b>	Clockwise when viewed from motor end	
<b>Motor</b> Type Speed Single Phase  Three Phase  Bearing Motor Protection	NEMA 56J Frame 60 Hz, 3450 RPM (2 poles) TEFC – ½ HP to 3 HP ODP – ½ HP to 3 HP, 115/230V TEFC – ½ HP to 3 HP ODP – ½ HP to 3 HP, 208-230/460V Ball Bearing Built-in overload protection (single phase)	60Hz, 1725 RPM (4 poles)  Explosion proof – consult factory Washdown duty – consult factory



**Instructions and Operation**

**Specifications – 2CDXU**

	Standard	Optional
<b>Size</b> Suction  Discharge	2CDXU70 – 1¼" NPT Thread 2CDXU120 – 1¼" NPT Thread 2CDXU200 – 1½" NPT Thread  1" NPT Thread	
<b>Range of HP</b>	2 HP to 5 HP	
<b>Range of Performance</b> Capacity Head	5.5 to 66 GPM at 3600 RPM 98 to 245 feet at 3600 RPM	
<b>Liquid handled</b> Type of liquid Temperature Working pressure	Clean water Maximum: 212 F (100 C) Maximum: 125 PSI (9 Bar)	
<b>Materials</b> Casing Impeller (closed type) Shaft Bracket Shaft Seal	304L Stainless Steel 304L Stainless Steel 304L Stainless Steel Aluminum or Cast iron Mechanical Seal – Carbon/Ceramic	Consult factory for optional seal types
<b>Direction of Rotation</b>	Clockwise when viewed from motor end	
<b>Motor</b> Type Speed Three Phase Motor Casing Bearing	TEFC/IP55 60 Hz, 3450 RPM (2 poles) 230/460V Aluminum Ball Bearing	



**Instructions and Operation**

**Specifications – 2CDU**

	Standard	Optional
<b>Size</b> Suction  Discharge	2CDU70 – 1¼" NPT Thread 2CDU120 – 1¼" NPT Thread 2CDU200 – 1½" NPT Thread  1" NPT Thread	
<b>Range of HP</b>	2 HP to 5 HP	
<b>Range of Performance</b> Capacity Head	5.5 to 66 GPM at 3600 RPM 98 to 245 feet at 3600 RPM	
<b>Liquid handled</b> Type of liquid Temperature  Working pressure	Clean water Maximum: 212 F (100 C)  Maximum: 125 PSI (9 Bar)	Maximum: 250 F (121 C) with optional high temperature seal
<b>Materials</b> Casing Impeller (closed type) Shaft Bracket Shaft Seal	304L Stainless Steel 304L Stainless Steel 304L Stainless Steel Cast iron Mechanical Seal – Type 21	High temperature version Mild chemical version
<b>Direction of Rotation</b>	Clockwise when viewed from motor end	
<b>Motor</b> Type Speed Single Phase  Three Phase  Motor Protection Bearing	NEMA 56J Frame 60 Hz, 3450 RPM (2 poles) TEFC – 2 HP to 5 HP ODP – 2 HP to 3 HP, 115/230V  TEFC – 2 HP to 5 HP ODP – 2 HP to 3 HP, 208-230/460V  Built-in overload protection (single phase) Ball Bearing	Explosion proof – consult factory Washdown duty – consult factory



Instructions and Operation

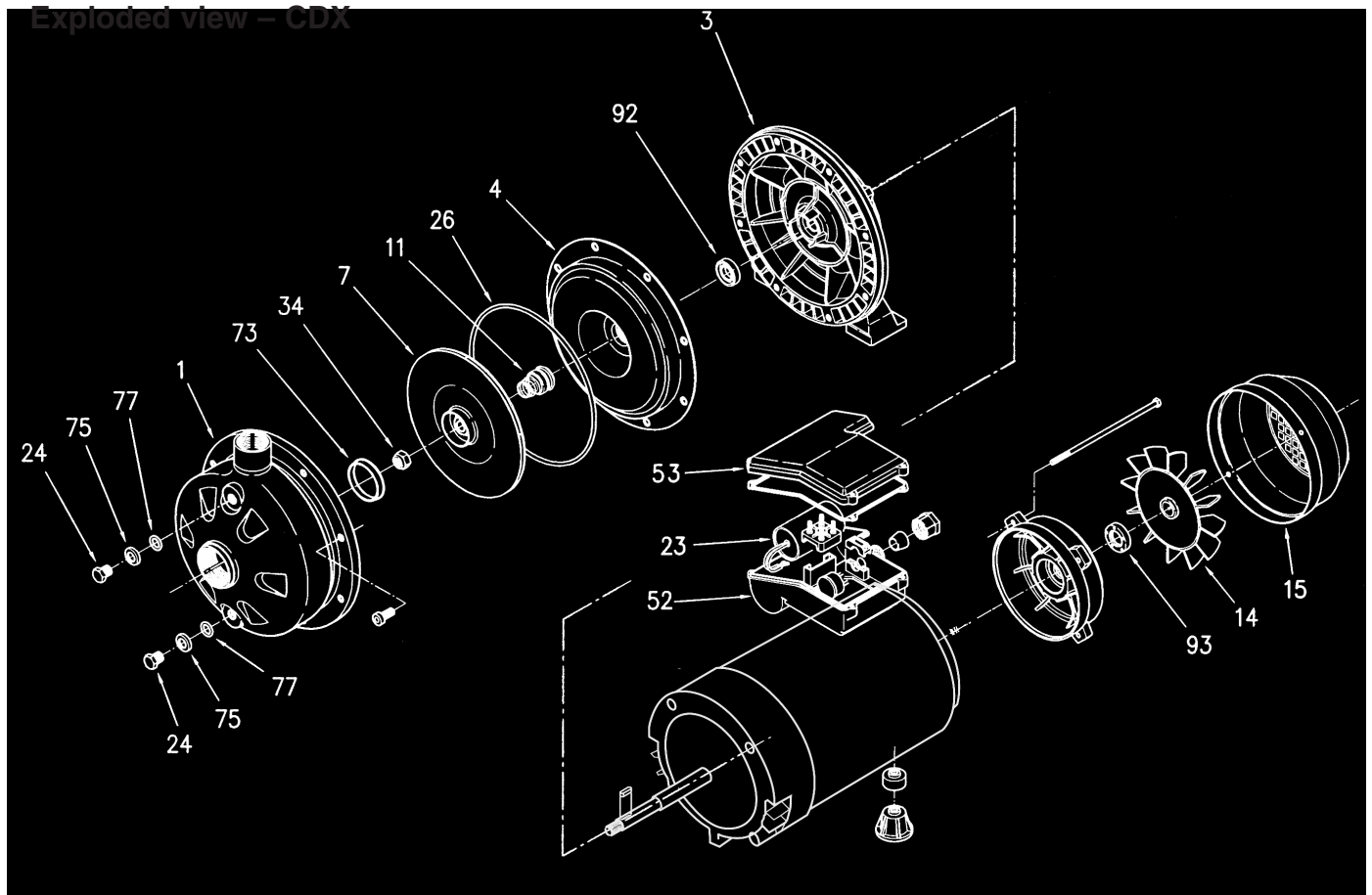

Location No.	Part Name	Material	No. for 1 Unit
001	Casing	304 Stainless	1
003	Motor bracket	Cast Aluminum	1
004	Casing cover	304 Stainless	1
007	Impeller	304 Stainless	1
011	Mechanical seal	Carbon/Ceramic	1
014	Fan	Polypropolene	1
015	Fan Cover	Steel	1
023	Capacitor	Single Phase only	1
024	Priming/Drain plug	304 Stainless	2
026	O-Ring	NBR	1
032	Key	304 Stainless	1
034	Impeller nut	304 Stainless	1
052	Terminal box	Plastic	1
053	Terminal cover	Plastic	1
073	Casing ring	NBR	1
075	Washer	304 Stainless	2
077	O-ring	NBR	2
092	Lip seal	-	1
093	Lip seal	-	1





Instructions and Operation

Sectional view – CDU

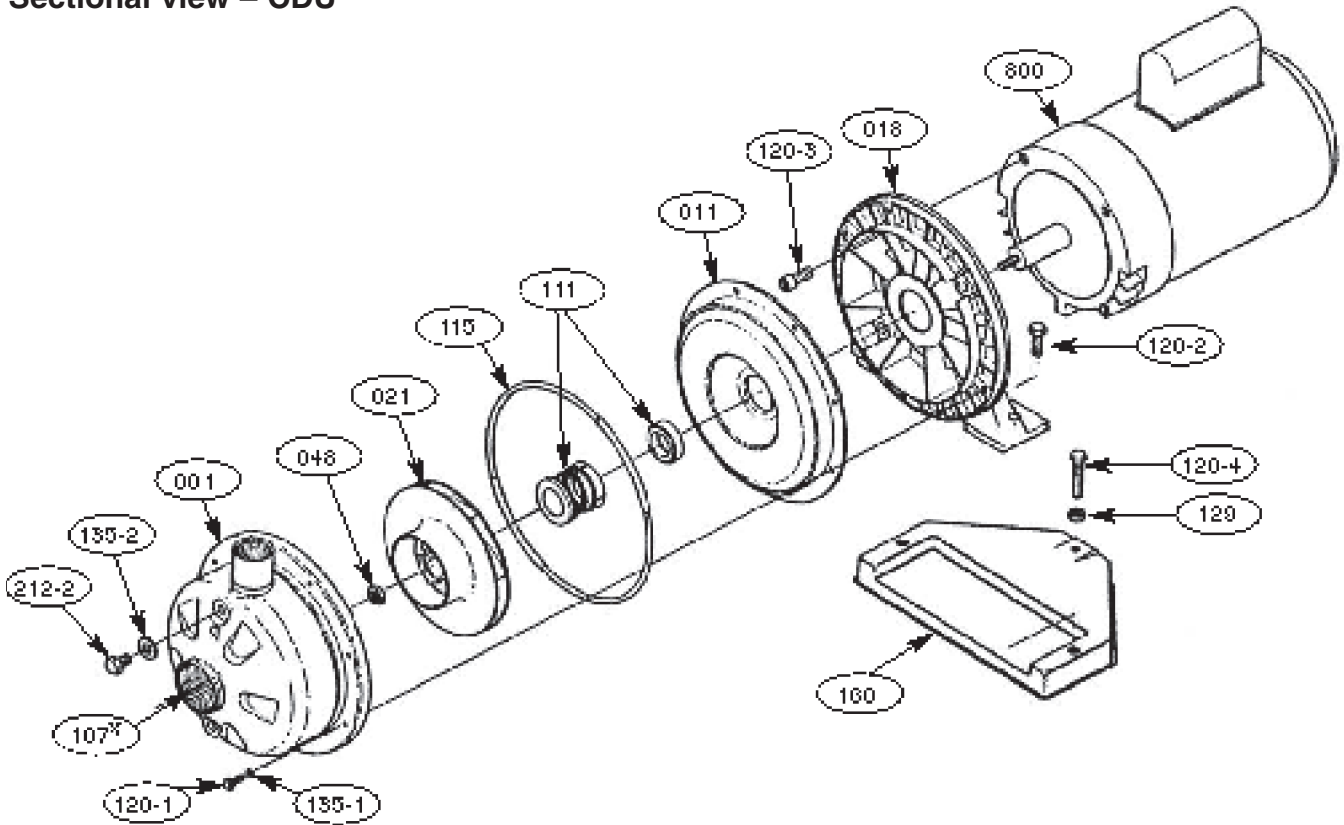

Part No.	Part Name	Material	No. for 1 Unit
001	Casing	304L Stainless	1
011	Casing cover	304L Stainless	1
018	Bracket	Aluminum	1
021	Impeller	304L Stainless	1
048	Impeller nut	304L Stainless	1
107*	Casing ring (*CDU 70 series only)	Viton	1
111	Mechanical seal	—	1
115	O-Ring	Viton	1
120-1	Bolt	304L Stainless	8
120-2	Bolt	304L Stainless	2
120-3	Bolt	304L Stainless	4
120-4	Bolt	304L Stainless	1
129	Nut	304L Stainless	1
135-1	Washer	304L Stainless	8
135-2	Washer	304L Stainless	2
160	Base	Steel	1
212-2	Plug	304L Stainless	2
800	Motor	—	1



Instructions and Operation

Exploded view – 2CDX

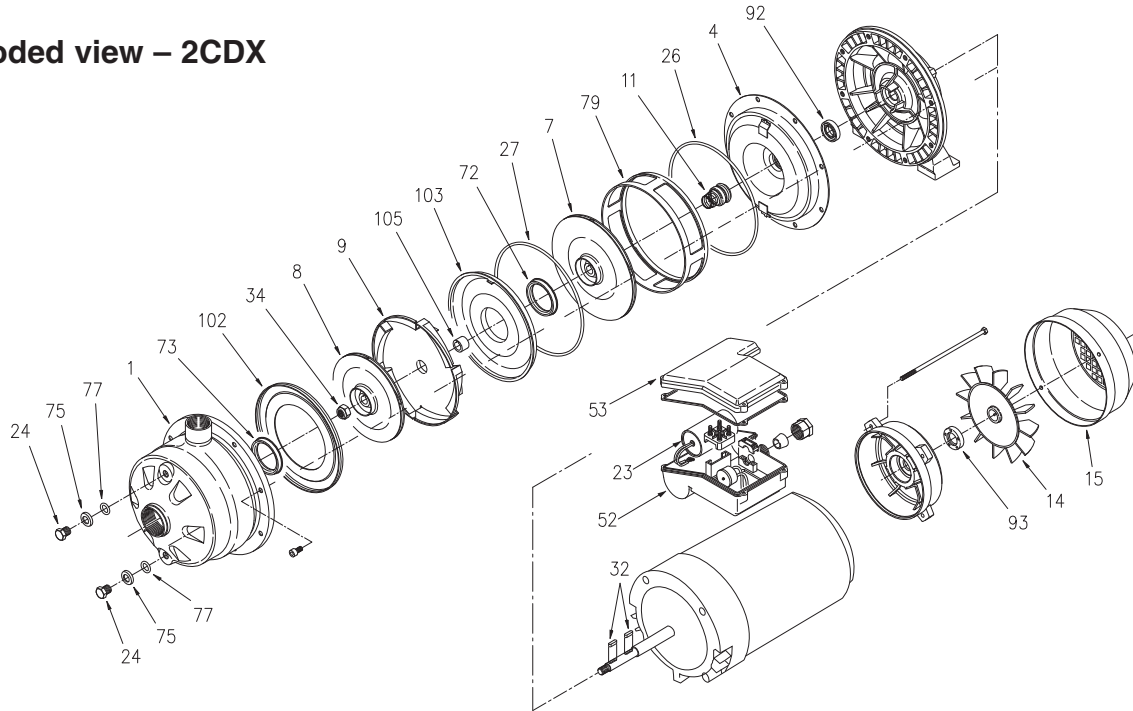

Location No.	Part Name	Material	No. for 1 Unit
1	Casing	304 Stainless	1
4	Casing cover	304 Stainless	1
7	Impeller	304 Stainless	1
8	Impeller	304 Stainless	1
9	Diffuser	304 Stainless	1
11	Mechanical seal	Carbon/Ceramic	1
14	Fan	Polypropolene	1
15	Fan cover	Steel	1
23*	Capacitor*	*Single phase only	1
24	Priming plug	304 Stainless	2
26	O-Ring	Viton	1
27	O-Ring	Viton	1
32	Key	304 Stainless	2
34	Impeller nut	304 Stainless	1
52	Terminal box	Polypropolene	1
53	Terminal cover	Polypropolene	1
72	Casing ring	Viton	1
73	Casing ring	Viton	1
75	Washer	304 Stainless	2
77	O-ring	Viton	2
79	Spacer diffuser	304 Stainless	1
92	Lip seal	–	1
93	Lip seal	–	1
102	Suction cover	304 Stainless	1
103	Conveyor cover	304 Stainless	1
105	Sleeve	304 Stainless	1

\*Note: Capacitor for Single Phase ONLY



Instructions and Operation

Sectional view – 2CDU

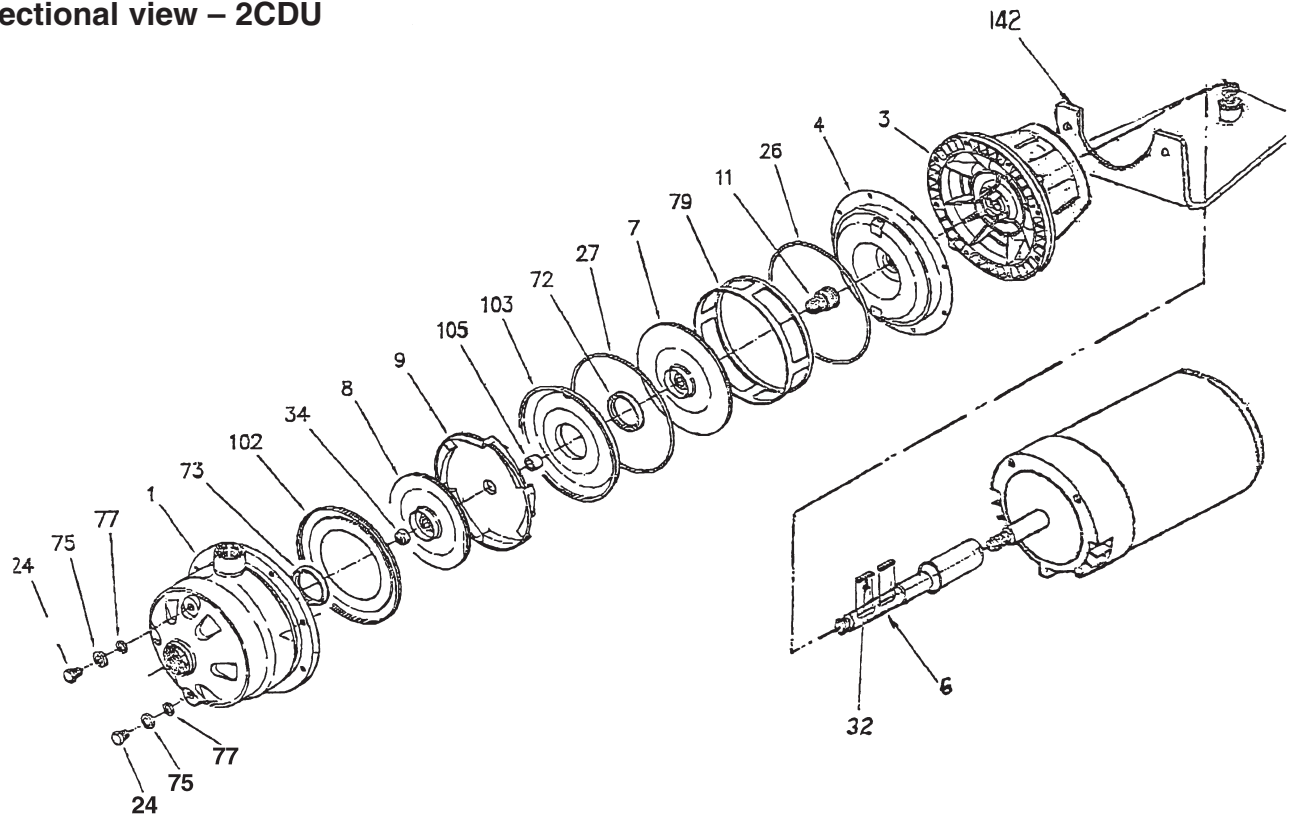

Location No.	Part Name	Material	No. for 1 Unit
001	Casing	304 Stainless	1
003	Motor bracket	Cast Aluminum	1
004	Casing cover	304 Stainless	1
006	Shaft extension	304 Stainless	1
007	Impeller	304 Stainless	1
008	Impeller	304 Stainless	1
009	Diffuser	304 Stainless	1
011	Mechanical Seal Type 21	Carbon/Ceramic	1
024	Priming plug/Drain plug	304 Stainless	2
026	O-Ring	Viton	1
027	O-Ring	Viton	1
032	Key	Stainless	2
034	Impeller nut	304 Stainless/Nylon	1
072	Casing ring	Viton	2
073	Casing ring	Viton	1
075	Washer	304 Stainless	2
077	O-ring	Viton	2
079	Spacer diffuser	304 Stainless	1
102	Suction cover	304 Stainless	1
103	Conveyor cover	304 Stainless	1
105	Sleeve	304 Stainless	1
142	Base	Steel	1



## Instructions and Operation

---

### Mounting Instructions

#### Mounting the Assembly

Do not operate the pump unless the assembly is securely and properly mounted.

Misalignment of the motor/pump assembly or not having the assembly reasonably level may cause pump vibration, noisy operation, fluid leaks, or air leaks and air locks in the suction pipe.

1. Place the motor/pump assembly in its intended operating position.
2. Level the pump through the centerline of the motor/pump assembly suction port.



#### WARNING

##### Initial Operation

Make certain the motor is not connected to a power source until the motor is properly assembled and mounted. Serious personal injury or damage to the motor/pump assembly could occur if the motor is activated improperly.

Only certified electricians should make electrical connections.

1. Prime the pump by adding fluid to the volute case through the top plug. To properly prime the pump, venting may be required.
2. Check the nameplate on the motor to determine the correct wiring procedure for your intended power source and if the motor is single or three phase. Connect the motor to a power source by following the wiring procedure on the motor's nameplate.

#### Note:

- a. Single phase motors are typically dual voltage. In some cases, three phase motors are tri-voltage. Check the nameplate and follow the proper wiring procedure for the voltage you are using. Improperly wiring the motor could result in damage to the motor.
- b. Three phase motors require a control box. Install overload protection to help prevent motor damage.
- c. Depending on the wiring, three phase motors may start in reverse. Interchange any two power leads to change the starting direction and pump rotation.
  - Always follow correct operating procedures.
  - Always disconnect the motor/pump assembly from all power sources before servicing the pump or motor.
  - Periodically check all power connections, bolts, screws, and the motor's mounting.
  - Failure to properly follow assembly and operating instructions could result in damage to the pump and motor.
  - Failure to properly install the impeller and impeller nut could result in damage to the pump and could cause serious personal injury.



**Instructions and Operation**

---

**Maintenance**

---

**Service**

Keep ventilation openings clear of extraneous objects which may hinder free flow of air thru motor. Motor bearings are lubricated during manufacture. Additional lubrication is not required during their normal lifetime.



**Draining**

The pump and piping should always be protected against freezing temperatures. If there is any danger of freezing, the unit should be drained. To drain the pump, remove the drain plug at the bottom of the volute, and remove the priming plug to vent the pump. Drain all piping.

---

**Disassembly Instructions – CDU, CDX, 2CDU, 2CDX**

All pumping parts can be removed from case without disturbing the piping.



POWER SUPPLY – Open the power supply switch contacts and remove fuses. Disconnect the electrical wiring from the motor.

**VOLUTE CASE**

- (a) Drain pump case by removing drain plugs.
- (b) Remove the bolts securing volute case to pump bracket.
- (c) Pry volute case from casing cover with a screwdriver.

**IMPELLER**

CDU – Hold the motor shaft with a screwdriver in the shaft end slot. Remove the impeller nut. Grasp and turn the impeller counterclockwise (as viewed from pump end).

CDX, 2CDX, 2CDU – Hold the motor shaft with a screwdriver in the shaft end slot. Use a wrench to remove the impeller nut. Slide impellers from the shaft.

**SEAL**

- (a) Remove the rotating part of the seal by pulling it off the shaft.
- (b) The stationary seat can be pressed from the casing cover.

**CHECK LIST FOR EXAMINATION OF PUMP PARTS**

IMPELLER - Replace the impeller if any vane is broken, excessive erosion shows, or if labyrinth surfaces are worn. Impeller nut should be replaced if damaged.

MECHANICAL SEAL - Seal face, O-ring and sealing members should be free of burrs and dirt. Complete seal assembly should be replaced if not in perfect condition.

SHAFT- Shaft surface under seal must be clean, smooth and without any grooves. It should be replaced if necessary.

VOLUTE AND SEAL PLATE LABYRINTH SURFACES (Wear Rings)- If worn, replace the necessary part. If furnished with pressed in wear rings, only the rings need be replaced.

**NOTE**

If replacement parts are ordered, please furnish the following information to your EBARA distributor:

- 1. Reference Numbers
- 2. Description of Pump Part
- 3. EBARA Model Number and Serial Number on the Nameplate.



---

**Instructions and Operation**

---

**CDU/CDX Assembly Instructions**

---

Position the pump on its end with the shaft up. The work surface should be level, capable of supporting the motor.

**WARNING**

Make certain the motor is not connected to a power source. Do not install or assemble the pump on a motor connected to a power source. Serious injury could occur if the motor activates during pump assembly.

**Assembling the Pump**

1. Position the motor bracket on the motor with the mounting feet toward the motor. Cross-tighten bolts to factory recommended torque of 6 ft. lbs.
2. Using finger pressure only, firmly press the stationary seal seat into the casing cover. Press the seat until it evenly bottoms out in the seat cavity.
3. Be careful not to damage the stationary seal.
  - a. Position the casing cover over the the motor shaft.
  - b. Align the casing cover holes with the motor bracket holes.
  - c. Firmly press the casing cover into position. (Casing cover may need to be tapped into place by using a rubber mallet.)
4. Ensure all seals have good contact.
  - a. Carefully press the rotating seal assembly onto the motor shaft. Ensure the face of the seal assembly has solid, square contact with the stationary seal seat.
  - b. The seal retainer must seal against the motor shaft.
  - c. Position the seal spring and seal washer. CDX pumps do not require seal spring washers.
5. Failure to properly install the impeller and the impeller nut could result in the impeller spinning off the shaft in three phase applications (when the motor may start in reverse rotation).

**For CDU pumps:**

- a. While holding the seal spring in place, thread the impeller clockwise onto the motor shaft.
- b. Use a screwdriver to hold the motor shaft stationary. Turn the impeller on the shaft until it spins down and bottoms out. Make certain that the impeller is firmly bottomed and sealed.
- c. Install the impeller nut onto the shaft in the same manner as the impeller was installed. Make certain the impeller nut is firmly sealed against the impeller. Apply lock tite to the impeller nut before installing.

**For CDX pumps:**

- a. Position key in keyway on shaft
  - b. Slide impeller onto shaft
  - c. Tighten impeller nut.
6. Position the Viton O-ring over the casing cover. Do not cut nick or damage the O-ring during installation.
  7. The discharge can be positioned in the direction desired.
    - a. Position the pump volute casing over the casing cover.
    - b. Rotate the discharge to the desired direction.
    - c. Align the bolt holes and secure the case to the casing cover with lock washers and cap screws.
    - d. Cross tighten the bolts to 3.4 lbs (factory recommended torque). Overtightening may result in stripping of the motor bracket threads.
  8. Position the mounting base on the pump and secure with cap screws.
  9. Place the bolt and lock nut on the back of the mounting base. Adjust the bolt height to support the motor and tighten the lock nut to secure the bolt height.
  10. Rotate the impeller to ensure proper alignment.



**Assembly Instructions – Models 2CDU, 2CDX**

---

**For 2CDX start with step # 3.**

1. Apply thread locker to the shaft extension. Thread shaft extension on to the motor shaft. Tighten to 10Nm ( 7.5 ftlb).
2. Attach motor bracket to the motor cross tightening the bolts. 8 Nm (6 ftlbs)
3. Install stationary seal in the casing cover. Press the seal until it evenly bottoms out in the seat cavity.
4. Carefully press the casing cover onto the motor bracket. Be sure to align the casing cover bolt-holes with the bolt-holes in the motor bracket.
5. Carefully press the rotating seal assembly onto the motor shaft. Ensure that the face of the seal assembly has solid, square contact with the stationary seat. Position the seal spring and spring washer. (2CDX pumps do not require a seal spring washer.)
6. Install the casing cover o-ring. Do not nick or cut the o-ring.
7. Install key in the location to accept the delivery side impeller. Reference the parts list to ensure the proper part number impeller is in the proper position.
8. Install sleeve and key for the suction side impeller.
9. Install diffuser spacer. Be sure to align the diffuser spacer notch with the casing cover spigot.
10. Install the o-ring on the conveyor cover.
11. Assemble the conveyor cover being sure to align the casing cover notch with the diffuser spacer spigot.
12. Install the diffuser.
13. Slide the suction side impeller onto the shaft into its proper position. Reference the parts list to ensure the proper part number impeller is in the proper position.
14. Install the suction cover.
15. Thread the self locking nut onto the shaft and tighten

**For 2CDU, go to step 16.A For 2CDX, go to step 16.**

16. Place casing onto the assembly, aligning the holes of the casing with the holes of the casing cover and the motor bracket. Thread the casing bolts and crass tighten to 8 Nm (6ft lbs) Go to step 19.
17. Place casing onto the assembly aligning the holes of the casing with the holes of the casing cover and motor bracket. Thread the M6x 16 bolts into the upper side holes. Thread the M6 X 30 bolts in the lower side holes. Cross tighten the casing bolts to 8Nm (6 ftlbs)
18. Fit the base onto the bolts protruding from the lower side holes. Using lock washers and nuts secure the base to the assembly.
19. Install nut and screw in the jack screw position in the base. Set the pump on a horizontal surface and loosen jack screw until it comes in contact with the bottom of the motor.
20. Rotate pump shaft to ensure proper alignment of assembly. Pump shaft should rotate with out rubbing if assembly is installation is correct.



**Instructions and Operation**

**Troubleshooting**

TROUBLE	POSSIBLE CAUSE	TROUBLESHOOTING
Pump does not run.	Faulty connection of power supply circuit. Wrong wiring of control circuit. Bound shaft Mechanical seal faces stuck together Faulty motor Damage to bearing	Check power supply circuit. Correct control circuit. Remove cause of obstruction. Release seal by turning shaft. Repair or replace motor. Repair or replace any damaged bearing.
Pump does not pump water. Inadequate quantity.	Considerable voltage drop. Rotation direction reversed. Lack of priming. High discharge head. Large piping loss. Clogged foot valve. Leakage from suction piping. Too high suction lift. Low water level.	Check incoming power. Correct rotation direction. Re-prime the pump. Re-examine the plan. Re-examine the plan. Clear foot valve suction. Check and repair suction piping. Re-install as per instructions. Foot valve in ample immersion.
Overcurrent	Considerable fluctuation of power supply voltage. Considerable voltage drop. Low head and overflow rate. Damaged bearing.	Check incoming power. Check incoming power. Throttle flow rate at outlet. Replace any damaged bearing.
Pump vibrates, excessive operating noise	Beyond rated capacity. Below minimum flow. Improper piping. Damaged bearing. Foreign matter clogging cooling fan.	Reduce flow rate. Consult distributor Secure piping again. Replace any damaged bearing. Remove foreign matter.
Pressurizing application. Pump starts and soon stops	Too limited pressure switch setting.	Replace pressure switch to wider range. Check and repair leaks.
Pump does not stop	Leakage in system. Too high pressure setting.	Reduce max pressure setting to the lower in pressure switch.

**MAINTENANCE:**

The pump does not require special maintenance.

The following rules must be observed for safe operation:

If the pump is not going to be used for a long period, the pump should be drained of water and flushed with clean water.

Where the pump is exposed to freezing temperatures, it should always be left drained when not in use.

\*All specifications subject to change without notice.





**Complete enclosed Registration Card and return to Ebara Pumps Americas Corporation.**

**EBARA PUMPS AMERICAS CORPORATION  
ROCK HILL, SOUTH CAROLINA  
COMMERCIAL PUMP / PRODUCTS LIMITED WARRANTY  
(EXCEPT MODEL OPTIMA SUMP PUMPS)**

Ebara Pumps Americas Corporation (EPAC) warrants to the original purchaser only ("Customer") that the EPAC Commercial Pump/Product ("Pump") will be free of defects in workmanship and material for a period of twelve (12) months from the date of installation or eighteen (18) months from the date of shipment by EPAC, whichever comes first, provided that notification of any such defect is promptly given in writing to EPAC. Customer may be required at EPAC's request to verify that it is the Customer of the Pump and that the Pump was installed and operated in accordance with EPAC's instructions.

EPAC's sole obligation under this warranty will be to repair or replace with a new or reconditioned Pump, such Pump as has failed or has been found to be defective during the warranty period, or at EPAC's sole option, to refund to the customer an equitable part of the purchase price. In no event shall EPAC's cost responsibility exceed the initial purchase price paid by the Customer for the Pump.

EPAC shall be liable only for the cost of the Pump, or the cost of repair or replacement of any defective Pump. Customer shall be responsible for labor, cost of removal and installation at Customer's premises, transportation and insurance costs to EPAC and any other incidental costs.

This warranty is void and does not apply if damage is caused by improper installation, improper maintenance, accident, alteration, abuse, misuse or if the Pump has been disassembled prior to warranty evaluation without written authorization from EPAC.

Warranty service and information for return procedures will be provided by EPAC upon receipt of written notice describing the defect or problem to:

Ebara Pumps Americas Corporation  
Warranty/Claims  
1651 Cedar Line Drive  
Rock Hill, SC 29730  
803-327-5005 Phone  
803-327-5097 Fax

**THE FOREGOING WARRANTY IS THE SOLE AND EXCLUSIVE WARRANTY ON THIS PUMP, AND ALL OTHER WARRANTIES, EXPRESSED OR IMPLIED, INCLUDING ANY WARRANTY OF MERCHANTABILITY OR FITNESS FOR A PARTICULAR PURPOSE, ARE DISCLAIMED AND EXCLUDED FROM THE TERMS OF THIS WARRANTY. EPAC'S SOLE OBLIGATION IN CASE OF ANY DEFECT WILL BE TO PROVIDE THE WARRANTY SERVICE SPECIFIED ABOVE THE FOREGOING IS CUSTOMER'S SOLE AND EXCLUSIVE REMEDY, WHETHER IN CONTRACT, TORT OR OTHERWISE AND EPAC SHALL NOT BE LIABLE FOR ANY CONSEQUENTIAL OR INCIDENTAL DAMAGES OF ANY KIND WHATSOEVER.**





*Contact your dealer or supplier  
for more information about other EBARA products*



---

**EBARA Standard Pump**

1651 Cedar Line Drive • Rock Hill, SC 29730  
(t) 803 327 5005 • (f) 803 327 5097  
info@pumpsebara.com • [www.pumpsebara.com](http://www.pumpsebara.com)  
© 2018 EBARA Pumps Americas Corporation

EPACCD(X)U2CD(X)U 0818